

# CI-400 SERIES

**Weighing Indicator**

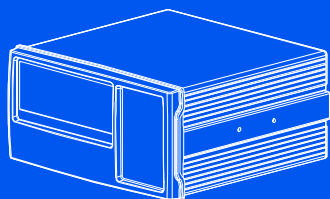



**CAS**



# Cautions for Your Safety

Please comply with 'Cautions for Your Safety', which will lead you to use the product safely and properly to prevent any dangerous situations.



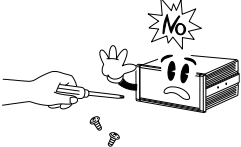

- Cautions are divided into 'Warning' and 'Alert', which mean as follows.
- Keep this manual in a place where product users can find out, after finish reading it.

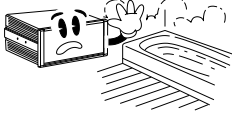
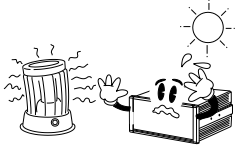
 <b>Warning</b>
'Warning' means a great possibility led to the death or heavy injury when instructions are violated.
 <b>Attention</b>
'Alert' means a great possibility led to the injury or material damage when instructions are violated.

## ⚠ Warning

<p>Never disassemble, repair or retrofit the product. It might exclude the product from the quality assurance and cause the damage to devices, electric shock or fire.</p>	<p>Ensure the power plug to be fully inserted to prevent shaking. Any instable connection might cause electric sparks to set fire.</p>	<p>Ensure the grounding of the product. Poor grounding might cause failure or electric shock upon electric leak.</p>
		
<p>Do not damage, process, excessively jerk, bend or twist the power cord. It might damage the power cord to cause fire or electric shock.</p>	<p>Keep any combustible spray or fire source away. It might cause fire.</p>	<p>Do not spray water to the outside of the product or use it in any humid place. It might deteriorate the insulation of electric parts that can cause the electric shock, fire risk or weighing errors.</p>
		
<p>Do not place the product to the direct sunlight or near any hot object like a heater. It might cause fire.</p>		
		

 **Attention**

<p>Check the weighing error anytime for the accurate weighing. Any use out of the allowed tolerance for the careless use or other causes might not ensure the accurate weighing.</p>	<p>Avoid any sudden shock to the product. It might damage the product to fail the accurate weighing.</p>	<p>Find a proper place to attach the rubber pad at the bottom of the indicator, which was shipped together.</p>
		
<p>Do not use the product at a place with sudden temperature changes or severe vibrations. It might cause the weighing error or failure.</p>	<p>Do not install the product at a place with the excessive electromagnetic wave. It might cause the wrong weighing.</p>	
		

**Our Dealers :** CAS feels that each of its valued customers should get the best service available. Whether it's the initial installation of our product, maintenance/repair work, or simply answering questions about our products, CAS Corporation and all of its Authorized Dealers are highly trained to assist you with any need regarding CAS products.

# Contents

<b>1. Features</b> .....	8
1-1. Features .....	8
1-2. Main Functions .....	8
1-3. Analog and A/D Conversion .....	9
1-4. Digital and Display .....	9
1-5. Product Specifications.....	10
1-6. Standard Specification .....	10
1-7. Option Specification.....	10
<b>2. Specifications in Appearance</b> .....	11
2-1. External Dimension.....	11
2-2. Front Panel Descriptions.....	12
2-3. Keyboard .....	15
2-4. Rear Panel Descriptions .....	17
<b>3. Installation &amp; Connection</b> .....	18
3-1. Loadcell Connection .....	18
<b>4. Weight Setup(Calibration) Mode</b> .....	20
4-1. Weight Setup(Calibration) Menu .....	21
4-2. How to Seal the Indicator(Sealing).....	30
<b>5. Weighing Mode</b> .....	31
<b>6. Test Mode</b> .....	35
<b>7. Set Mode</b> .....	40
<b>8. OPTION</b> .....	93
8-1. Relay In4 / Out6.....	93
8-2. Analog Out .....	95
8-3. BCD-OUT .....	97
8-4. BCD-IN .....	99
<b>9. Serial Communication</b> .....	101
9-1. RS-232C Port Connection .....	101
9-2. Current loop .....	102
9-3. RS-422/RS-485 Serial Communication (Option).....	103
<b>10. Appendix</b> .....	104
<b>11. Error Message</b> .....	116
11-1. Error Message from the Weight Setup Mode .....	116
11-2. Error Message from the Weighing Mode .....	117

## Preface

Thank you very much for purchasing CAS International Indicator.

This produce is characterized by the excellent performance and luxurious features through strict examinations, as well as elaboration for each part under our strict quality control.

CAS Indicator (CI-series) is a product with rich functions and various external interfaces, which is designed to comply well with special requirements in a variety of industrial fields under strong and beautiful designs in appearance.

In addition, it is designed for the user-friendly programs for the easier use of indicator by any user with the built-in message display functions to help users understand the product.

Please use the product right and sufficiently utilize functions of CI-400 series as you read this manual thoroughly before using CI-400 series.

# 1. Features

## 1-1. Features

- High speed, High accuracy
- High speed micro processor adoption
- A/D conversion speed : Maximum 200 times/sec
- Appropriate for weight and measurement system
- Easy operation and various options.
- Simple and prompt Full Digital Calibration (SPAC™: Single pass automatic span Calibration)
- RFI/EMI screened
- Watch Dog circuitry (System restoration)
- Weight Back-up (Weight memory at sudden power failure)

## 1-2. Main Functions

- Store date, time and calculated data at sudden power failure
- Various specification on weight conversion speed. (Digital filter function)
- Various printer connection. (RS-232C Serial printer)
- Tare weight setting with keys
- Storage of measured times.
- Set Point input & highest, lowest limit input
- External input 4 relay.(CI-405, CI-407)
- External output 6 relay.(CI-405, CI-407)
- Users can set the desirous max. weight and a division freely
- Control various external equipment by inner external input/output. (option)
- Print date and time by inner clock
- Self hardware Test.
- Prompt A/S is available for Test of each part of circuit by module is possible.

### 1-3. Analog and A/D Conversion

Input sensitivity	0.3 uV/D(Certification), 0.2 uV/D(None)
Zeroing range	0 ~ 2 mV/V
Loadcell supply voltage	DC 5V
Maximum signal input voltage	3.0mV/V
Zero variation with temperature	ZERO : $\pm 10$ PPM / $^{\circ}$ C SPAN : $\pm 10$ PPM / $^{\circ}$ C
Input Noise	$\pm 0.6 \mu$ V P.P
Input Impedance	10 M $\Omega$
A/D conversion method	$\Delta \Sigma$
A/D resolution	1,000,000 Count(20bit)
A/D conversion speed	350 rounds / Sec
Non-straightness	0.01 % FS

### 1-4. Digital and Display

Span Calibration	Full Digital Calibration (Single automatic span Calibration)
Display	7-Segment 3 Digits Red FND 2EA (Font : 11 (W) X 20(H) mm)
	7-Segment 3 Digits Red FND 8EA (CI-405,407) (Font : 4 (W) *8 (H) mm)
Key	Number Key and Function Key (15 EA)
Division	X1, X2, X5, X10, X20, X50
Display Below Zero	“ - ”minus
Tare Subtraction	Full capacity
Sign for status	Stable, Zero, Tare, Gross/Net, Auto, Print, Hold, RX, TX (CI-401) Stable, Zero, Tare, Gross/Net, SP1, SP2, SP3, SP4, Comm (CI-405, CI-407)

## 1-5. Product Specifications

Power	SMPS - AC 100-240 V~, 50-60 Hz, 0.2 A
Product Size	185(W) x 102(D) x 92(H)
Temperature Range	-10 °C ~ +40 °C
Product Weight	Approx. 1.2 kg
Fuse Capacity	0.5 A L250 V
Power Consumption	Approx. 3.9 W

## 1-6. Standard Specification

Standard - 1	RS232 Interface(Port1, Port2)
Standard - 2	Current Loop Interface
Standard - 3	External Input(Input 4)

## 1-7. Option Specification

Option - 1	Analog V-out (0 -10 V) or I-out (4-20 mA)
Option - 2	BCD Out
Option - 3	BCD In
Option - 4	Relay module Type1(Input 4, Output 6)
Option - 5	RS-422/485 Interface

\* Ensure to affirm before purchasing the product since there may be a limitation for the option module that can be used depending on the program version.

## 2. Specifications in Appearance

### 2-1. External Dimension

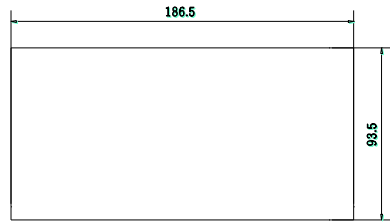
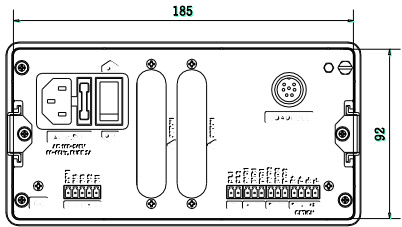
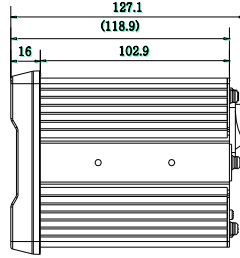
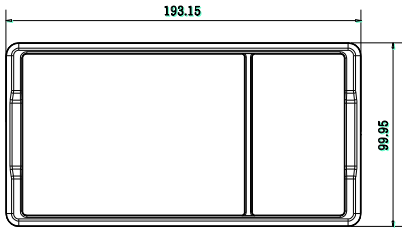

INSERT PANEL SIZE

## 2-2. Front Panel Descriptions

### ■ CI-401



### Display Information

LED	Main Function
STABLE	Indicated when the weight is stable
ZERO	Indicated when the weight is "0"
TARE	Indicated when tare is entered
G/N	Indicates gross and net weight after setting tare
AUTO	Indicated when the Data Print-out is Automatic during Stable Weight
PRINT	Indicated during data transmission to an External Print communication Port
HOLD	Indicated when operating the hold function
RX	Indicates status of receiving data during communication
TX	Indicates status of transmitting data during communication

■ CI-405



### Display Information

LED	Main Function
STABLE	Indicated when the weight is stable
ZERO	Indicated when the weight is "0"
TARE	Indicated when tare is entered
G/N	Indicates gross and net weight after setting tare
SP1	Indicated when Step1 Relay ON is output.
SP2	Indicated when Step2 Relay ON is output.
SP3	Indicated when Step3 Relay ON is output.
SP4	Indicated when Step4 Relay ON is output.
COMM	Indicates status of transmitting or receiving data during communication

■ CI-407















### Display Information

LED	Main Function
STABLE	Indicated when the weight is stable
ZERO	Indicated when the weight is "0"
TARE	Indicated when tare is entered
G/N	Indicates gross and net weight after setting tare
SP1	Indicated when Step1 Relay ON is output.
SP2	Indicated when Step2 Relay ON is output.
SP3	Indicated when Step3 Relay ON is output.
FINISH	Indicated when FINISH Relay ON is output.
COMM	Indicates status of transmitting or receiving data during communication



## 2-3 Keyboard

### Function Key

	<p>* Adjust the weight display near the zero-set to 0. (2%, 5%, 10%, 20%, 100% ranges can be selected.)</p>
	<p>* For every press, alternate between total/net load and display the weight with the lamp indicator.</p>
	<p>* Use the when weighing with the container. * Press the key to save the current weight as the container weight. * To remove the container press the key when the load board is empty.</p>
	<p>* Press the key to print the currently designated power format.</p>
	<p>* Use when checking the subtotal value (partial aggregate).</p>
	<p>* Use when checking the total value (aggregate).</p>
	<p>* Use to change the product number.</p>
	<p>* Use to input the item code.</p>

	<p>* Use to change the Set Point.</p>
	<p>* Use when weighing a moving object.</p>
	<p>* Use to enter the menu mode.</p>
	<p>* Can be customized to suit the needs.</p>

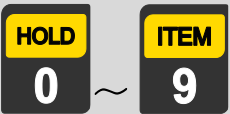
### Editor Key

	<p>* It enters 0~9 in the input numeric mode</p>
	<p>* Use when deleting all input.</p>
	<p>* Use to enter the menu mode</p>

## 2-4. Rear Panel Descriptions

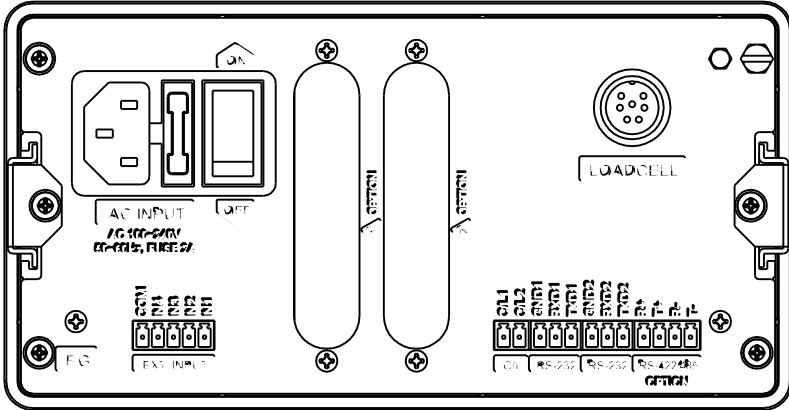

- LOAD CELL : Port for connection. 6Wires Loadcell
- C/L : Current loop Interface Port
- RS-232 : Serial Interface Com Port (COM1, COM2)
- RS-422/485 : Serial Interface Com Port (RS-422/485)
- AC INPUT : AC 100 – 240 V~ (50-60 Hz) ara available.  
FUSE – T0.5AL250V
- OPTION : When Option in Use, please connect.
- EXT. INPUT : External Input Port (INPUT : 4)

### 3. Installation & Connection

#### 3-1. Loadcell Connection

Connect the load cell connector to the load cell port which is in the backside of the indicator.

#### \* Connection method

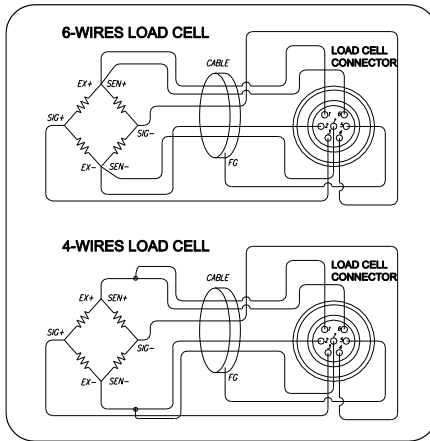

Pin No	Pin Function	Color
1	EXC+	RED
2	EXC-	WHITE
3	SIG+	GREEN
4	SIG-	BLUE
5	SHIELD	
6	SEN+	BROWN
7	SEN-	BLACK

Note 1. In case of 4 wires load cell, connect EX+ with SEN+, and connect EX- with SEN-.

Note 2. Wire color can be different depending on the load cell's manufacturer or it's model.

\* Relationship between the load cell output and input sensitivity.

The input sensitivity of this product is maximum 0.2 uV/digit or more.

The following equation should be satisfied upon the system design.

**\* Relationship between the load cell output and input sensitivity.**

$$0.2 \text{ uV} \leq \frac{\text{Applied voltage of load cell} \times \text{Output voltage of load cell} \times \text{Value of a division}}{\text{Rated capacity of load cell} \times \text{Number of load cell}}$$

Example 1) Number of load cell: 4 ea  
Rated capacity of load cell: 500 Kg  
Rated output of load cell: 2mV/V  
Value of a division: 0.10 Kg  
Applied voltage of load cell: 5V (= 5,000 mV)

According to the equation →  $(5000 \text{ mV} * 2 \text{ mV} * 0.1 \text{ Kg}) / (500 \text{ Kg} * 4) = 0.5 \geq 0.2 \text{ uV}$   
As the calculated value is greater than 0.2 uV, this weight system design has no problem.

Note 3. It can check the mV/V value in the testmode3

## 4. Weight Setup (Calibration) Mode

### What is the weight setup?

It refers to the calibration to set the displayed value to the actual weight in displaying weights.

### How to Access to the Weight Setup Mode

Remove the blot on the rear panel and connect both of CAL pin(check picture below) And

turn on the power supply and push the **TARE** **3** key same time, you can access to weight setup mode

Press the **CLEAR** **HOME** key in the weight setup mode to return to weighing mode

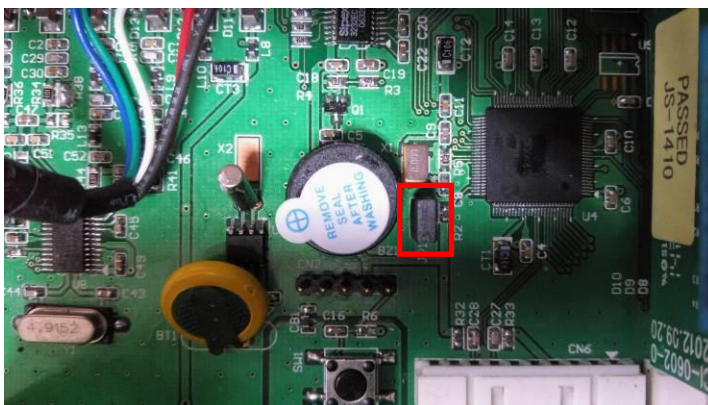





## 4-1. Weight Setup(Calibration) Menu (CAL1 – CAL9)





- CAL 1 : Maximum capacity calibration
- CAL 2 : Minimum division calibration
- CAL 3 : Zero-set and span calibration
- CAL 4 : Hopper weight setting
- CAL 5 : Direct calibration
- CAL 6 : Zero adjustment
- CAL 7 : Factor calibration
- CAL 8 : Gravity adjustment
- CAL 9 : Setting dual range

### CAL 1

#### CAL 1-1







Function : Setting Unit(Unit) Range of set value : 1 ~ 3		
Used key	Display	Descriptions
Using numeric keys  ~  Enter Unit.  = Set,  = Cancel	1. kg	Unit : kg
	2. ton	Unit : ton
	3. gram	Unit : g

#### CAL 1-2 (Maximum capacity calibration)

Function: Setting Maximum Value Range of set value: 1 ~ 99,999		
Used key	Display	Descriptions
Using numeric keys  ~  Enter maximum weight  = Set,  = Cancel	C= 10000	Max value = 10000 kg
	C= 10	Max value = 10 kg

Reference 1. The maximum capacity of the weighing scale can measure and display.

## CAL 2 (Minimum division calibration)

Function: Minimum division and decimal position setting Range of set value: 0.001 ~ 50		
Used key	Display	Descriptions
Using numeric keys   Enter minimum division	d= 0.001	Minimum division 0.001 kg
 = Set,  = Cancel	d= 0.01	Minimum division 0.01 kg
	d= 0.1	Minimum division 0.1 kg
Push  when entering a decimal print	d= 1	Minimum division 1 kg
	d= 10	Minimum division 10 kg





Reference 1. When  CLEAR is pressed with decimal point calibrated, 'CAL2' is exited.

Reference 2. For external exploded view, set within the value of maximum capacity divided by the readability, 1/30,000. If the external exploded view is greater than 1/30,000, "Err20" will be displayed.

Reference 3. The decimal point positions is determined as the decimal position of the readability set from 'CAL2'.

## CAL 3(Zero-set and span calibration)



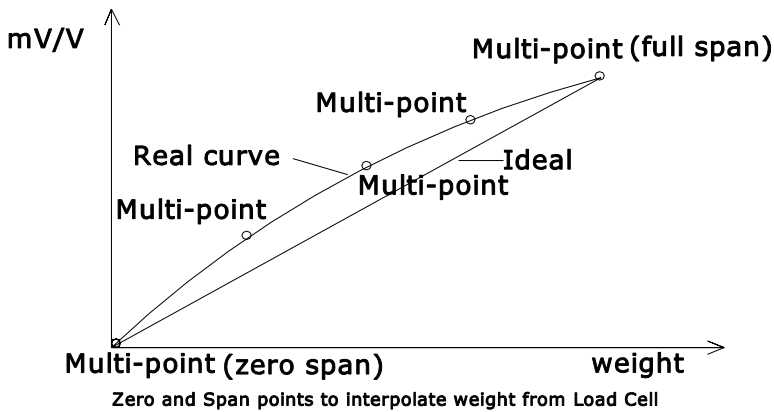

### CAL 3-1

Function: Setting Multi Calibration Step		
Range of set value: 1 ~ 5		
Used key	Display	Descriptions
Using numeric keys Set the multi step,    = Set,  = Cancel	STEP- 1	Setting multi calibration for step 1 (CAL3-3 and CAL 3-4 are carried out once)
	STEP- 5	Setting multi calibration for step 5 (CAL3-3 and CAL 3-4 are carried out five times.)

\* Function used to compensate the load cell power by calibrating multipoints in a particular sector when the actual curve of the load cell is not linear like it is in the figure below.







### CAL 3-2

Function: Zero Calibration		
Used key	Display	Descriptions
   = Set,  = Cancel	UnLoAd  1234  - - -	Empty the load tray and press the setup key.  The current weight value is displayed. Confirm 'Stable' and press the setup key.  Zeroing in progress...



Reference 1. If the zeroing is completed without any error, it will automatically advance to the counterweight weight setting (CAL 3-3) with no need of further input.

### CAL3-3

Function: Setting Weight Range of set value: 1 ~ 99,999		
Used key	Display	Descriptions
Using numeric keys  	LOAD 1	It means the weight setting mode. (Number = multi calibration number)
Set the counterweight values  =Set,  =Cancel	W=100.00	100.00 (unit: Kg or Ton)
	W= 0.10	0.10 (unit: Kg or Ton)

Reference 1. The counterweight should be set within 10~100% of the maximum capacity.

### CAL3-4

Function: Weight Calibration		
Used key	Display	Descriptions
 =Set,  =Cancel	LoAd 12345 ---	Load the weight set in CAL 4-3 and press the setup key. The current weight value is displayed. Confirm 'Stable' and press the setup key. Span adjustment in progress...

Reference 1. Repeat 'CAL3-3' and 'CAL3-4' according to the number of STEPs set in 'CAL3-1'.

At this instance, the weight value must be set to be greater than the previous values.

Reference 2. If the span calibration is completed without any error, "SUCCESS" will be displayed and will advance to the weight verification mode.

Reference 3. If there are no problems after weight verification, pressing  key will move to 'CAL3'.

## CAL 4(Hopper weight setting)

### CAL 4-1

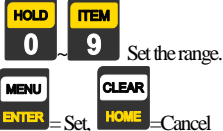
Function: Setting Multi Calibration Step Range of set value: 2 ~ 5		
Used key	Display	Descriptions
Using numeric keys  = Set, = Cancel	STEP- 2	Setting multi calibration for step 2 (for hopper system)
	STEP- 5	Setting multi calibration for step 5 (for hopper system)

### CAL 4-2

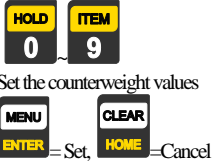
Function: Setting Weight Range of set value: 1 ~ 99,999		
Used key	Display	Descriptions
Using numeric keys  = Set, = Cancel	LOAD 1	It means the weight setting mode. (Number = multi calibration number)
	W=100.00	100.00 (unit: Kg or Ton)
	W= 0.10	0.10 (unit: Kg or Ton)

Reference 1. Set the counterweight within 10~100% of the maximum capacity

### CAL 4-3

Function: Weight Calibration		
Used key	Display	Descriptions
	LoAd 12345 - - -	Load the weight set in CAL 4-3 and press the setup key. The current weight value is displayed. Confirm 'Stable' and press the setup key. Span adjustment in progress...



Reference 1. Repeat 'CAL4-2', 'CAL4-3' according to the number of STEPs set in 'CAL4-1'.

At this instance the weight value should be calibrated to be greater than the previous values.



Reference 2. If the span calibration is completed without error, it will advance to CAL-4.

## CAL 5(Direct Calibration)



### CAL 5-1

Function: Direct input about the zero value of loadcell Range of set value: 1 ~ 99,999		
Used key	Display	Descriptions
Using numeric keys  Enter the output value.  ENTER = Set, HOME = Cancel	ZE-CAL	Direct zero input mode
	0.0000	Loadcell zero = 0.0000 mV/V
	0.1000	Loadcell zero = 0.1000 mV/V

### CAL 5-2

Function: Direct input about the span value of loadcell Range of set value: 1 ~ 99,999		
Used key	Display	Descriptions
Using numeric keys  Enter the output value.  ENTER = Set, HOME = Cancel	SP-CAL	Direct span input mode
	1.2000	Loadcell span = 1.2000 mV/V
	2.0000	Loadcell span = 2.0000 mV/V





## CAL 6(Zero-set adjustment)

Function: Zero adjustment - calibration when any zeroing error occurs.		
Used key	Display	Descriptions
 = Set,  = Cancel	2-CAL	Empty the load tray and press the setup key.
	1234	The current weight value is displayed. Confirm 'Stable' and press the setup key.
	- - -	Zero adjustment in progress...

Reference 1. Use when the zeroing is failing due to shock. (Zero-set range is 0 ~ 2 mV/V)

Reference 2. If zero-set adjustment is completed without error, advance to 'CAL-1'.

## CAL 7(Factor Calibration)





Function: Factor Calibration		
Used key	Display	Descriptions
Using numeric keys   Set the weight factor.  = Set,  = Cancel  Push  when entering a decimal print	NOTUSE  FACtor  12345	This function cannot be used because of multi calibration.  It means you entered the factor correction mode.  The current factor is displayed.

Reference 1. This menu is for weight calibration when counterweight is not available. Regular users will not need to use this.

Reference 2. Can only be used when the multicalibration range of 'CAL3-1' is set to 1.

Reference 3. To enter the FACTOR adjustment mode, PASSWORD must be entered.



## CAL 8(Gravity correction)

Function: Gravity Adjustment		
Used key	Display	Descriptions
<p>Using numeric keys   Enter an initial gravity value.</p> <p> = Set,  = Cancel</p> <p>Push  when entering a decimal print</p>	<p>G-CAL</p> <p>Gr-CAL</p> <p>9.XXXX</p> <p>Gr-SET</p> <p>9.XXXX</p>	<p>It means you accessed to the menu for the gravity adjustment.</p> <p>Set the gravity for the production place.</p> <p>Set the gravity for the place to use the product.</p>

Reference 1. If the gravity between the indicator production location and the location of use is different, gravity can be corrected using this function.





## CAL 9(Dual range setting)

### CAL 9-1

Function: Setting Dual Range		
Range of set value: 0 ~ 1		
Used key	Display	Descriptions
<p>Set the use status for dual function</p> <p> = Set,  = Cancel</p>	DUAL- 0	Dual range function is not used.
	DUAL- 1	Dual range function is used.

Reference 1. If the resolving power is greater than 1/10,000, "OVER" will be displayed and will return to the CAL menu mode.

## CAL 9-2

Function: Setting the applied section for the Dual Range		
Range of set value: 0 ~ 99999		
Used key	Display	Descriptions
<p>Using numeric keys Enter dual values.</p> <p>    = Set,  = Cancel</p>	<p>M 1000</p> <p>M 5000</p> <p>M 10000</p>	<p>Dual range is applied to less than 1000kg.</p> <p>Dual range is applied to less than 5,000kg.</p> <p>Dual range is applied to less than 10,000kg.</p>

Reference 1. If the input value is greater than the maximum capacity, "ERR SET" will be displayed and will return to the CAL menu mode.

## 4-2 How to Seal the Indicator (Sealing)

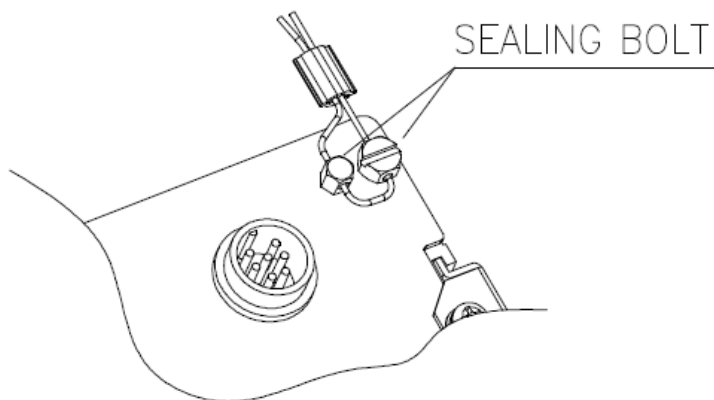
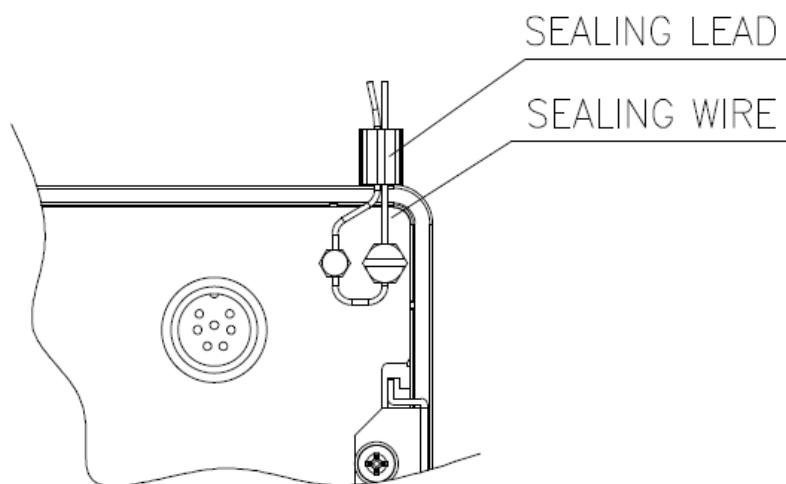

## 5. Weighing Mode

### (1) Zero-set Function (used when changing the zero-set)

	Display Part or Used Keys	Load Plate	Description
Step 1		Empty	State with zero changed
Step 2			Push the zero key
Step 3		Empty	State after performing zero function. Namely, the current weight is designated as 0/kg.

Note 1. Operating range for the zero key is possible between  $\pm 1\%$  ~  $\pm 99\%$  of the maximum weight. Operating range for the zero key is designated in Menu No. [F1.15].





Note 2. Menu No. [F1.14] designates whether to perform zero function only if the current weight is stabilized or even when it is unstable.

### (2) Tare function (used when weighing using a container)





- Maximum tare setting range: maximum capacity

	Display Part or Used Keys	Load Plate	Description
Step 1		Tare Placement	State with tare placed on load plate Weight plate : 1.000 kg
Step 2			Push the tare key
Step 3		Tare	State with NET lamp turned ON and tare registered





### (3) Product number changing

	Display Part or Used Keys	Load Plate	Description
Step 1			Press ID key.
Step 2			Product Number : 1
Step 2			Change the product number.
Step 3			Item number is saved.

### (4) Item number changing



	Display Part or Used Keys	Load Plate	Description
Step 1			Press Item code key.
Step 2			Item Code = 1
Step 2			Change the item number.
Step 3			Item number is saved.

### (5) Set point changing

	Display Part or Used Keys	Load Plate	Description
Step 1			Press Item key.
Step 2			Displayed current setpoint number.
Step 2	 		Change the set point value
Step 3			Set point is saved
Step 4			Repeat step1~3 until end point of max set point

### (6) Subtotal Print

The product number of the steel reinforcement is assumed to be '10'.



	Display Part or Used Keys	Load Plate	Description
Step 1			Select the item number code as '10'
Step 2			Push No.5(Subtotal) key.
Step 3			The subtotal value of item No.10 is printed in the designated form.

Reference 1. The print format is designated as below.

-----	
SUB-TOTAL	
-----	
DATE	2012/ 1/ 1
TIME	09:30
ID	1
COUNT	5
TOTAL	350.0 kg

Reference 2. The subtotal DATA is automatically or manually deleted based on the menu number[F3-03].

## (7) Total Print

	Display Part or Used Keys	Load Plate	Description
Step 1			Push No.6(Total)key
Step 2			Sum of all subtotal information item Nos.0-99 is printed as in the designated form.



Reference 1. The print format is designated as below.

-----	
GRAND-TOTAL	
-----	
DATE	2012/ 1/2
TIME	10:30
ID	10
COUNT	123
TOTAL	12350.0 kg

Reference 2. The subtotal DATA is automatically or manually deleted based on the menu number[F3-03].

## 6. Test Mode

### How to enter test mode

Press the  key whilst in normal mode and select test mode by pressing  key.



or when the power is turned on while pressing  key in the front of the indicator.

Push the  key in the test mode to return to weighing mode.















### Test Menu (1 – 11)

- 1 : Key Test
- 2 : Display Test
- 3 : AD Test
- 4 : Communication Test
- 5 : Print Test
- 6 : External Input/output Test(OPTION)
- 7 : A-OUT Test(OPTION)
- 8 : BCD IN Test(OPTION)
- 9 : BCD OUT Test(OPTION)
- 10 : Memory Test
- 11 : RTC Test (OPTION)



## TEST 1 Key Test

Function: Key test		
Used key	Display	Descriptions
  : Next Menu Other keys : Test	KEY 01	When you press any key to test, the number and code for the key are displayed on the screen.



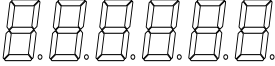

< Key List >

Key	No	Code	Key	No	Code	Key	No	Code
	F1	28		3	3		8	8
	F2	29		4	4		9	9
	F3	30		5	5		0	0
	1	1		6	6		CLEAR	27
	2	2		7	7		ENTER	30

## TEST 2 Display Test



Function: Display Screen Test		
Used key	Display	Descriptions
 : Cancel  : Next Menu		All LED lamp is on.

### TEST 3 AD Test

Function: Load cell test and A/D conversion test		
Used key	Display	Descriptions
 : Cancel    : Next Menu	XXXXXX	The internal value for the current weight value is displayed.



Reference 1. Press  to display the load cell output as m/V units.

### TEST 4 Communication Test

Function: Serial Communication Test		
Used key	Display	Descriptions
  : Next Menu Other keys: Test	Tx--Rx ----- 02--04	Status to wait for transmission or reception Transmission: 2, Reception: 13

- Reference 1. Run this test while the communication program in the computer (ex: Hyper Terminal) is executing after connecting a serial port in the computer to the serial port on the back.
- Reference 2. Send '1' from the computer keyboard, check whether or not '1' is received properly on the indicator's screen, and then check whether or not '1' is received properly on the computer after pressing '1' from the indicator's keyboard.



### TEST 5 Print Test

Function : Printer Test		
Used key	Display	Descriptions
  : Next Menu Other keys: Test	PRINT	No error in printer. Do this test after connection serial printer.

- Reference 1. Use COM2 PORT  
Reference 2. Print out the following form.



TEST OK

## TEST 6 External Input/output Test (OPTION)

Function : External Input / Output Test		
Used key	Display	Descriptions
  : Next Menu Other keys : Test	I - X O - X ----- I - 2 O - 4	Displayed in the external input section when there is an external input. Push 1~6 key to execute weighing external input : 2, output : 4



Reference 1. This test operates only if Ext IO Option Card is mounted

## TEST 7 A-OUT Test (OPTION)

Function : A-Out Test		
Used key	Display	Descriptions
  : Next Menu Other keys : Test	25 P	The output level of Aout is raised by 25% each time the key is pushed.



Reference 1. This test operates only if Analog out Option Card is mounted.

## TEST 8 BCD IN Test (OPTION)

Function : BCD-IN Test		
Used key	Display	Descriptions
  : Next Menu Other keys : Test	IN--XX	When BCD In is detected external signal, BCB code will be display in CI-400



Reference 1. This test operates only if BCD-IN Option Card is mounted.

## TEST 9 BCD OUT Test (OPTION)



Function : BCD-OUT Test		
Used key	Display	Descriptions
  : Next Menu Other keys : Test	111111	BCD Out automatically increases the output value per digit by 1

Reference 1. This test operates only if BCD out Option Card is mounted.

## TEST 10 Memory Test

Function: Memory Test		
Used key	Display	Descriptions
  : Next Menu	ROM OK ROM NG	Display EEPROM status



## TEST 11 RTC Test (OPTION)

Function: RTC Test		
Used key	Display	Descriptions
  : Next Menu	SEC XX	XX : Displaying the progress of seconds (SEC)

Reference 1. Press  key to reset seconds (SEC).

## 7. Set Mode

### How to enter set mode

Press  whilst in normal mode and select Set Mode by pressing  key.

After testing in set mode, press  to enter weighing mode.

Classification	Menu	SubMenu
1. General Setting (1. GEN)	F1.01	Set AD speed
	F1.02	Set average filter
	F1.03	Set Low Pass Filter
	F1.04	Set Band Stop Filter
	F1.05	Not use
	F1.06	Set stable range
	F1.07	Set Automatic Zero Tracking Compensation
	F1.08	Set Weight Back-up
	F1.09	Set Hold Type
	F1.10	Set Average Hold time
	F1.11	Set Hold Canceling Conditions
	F1.12	Set Automatic Hold Starting Conditions
	F1.13	Set Automatic Hold Canceling Conditions
	F1.14	Set Key Operating Conditions
	F1.15	Set Zero range
	F1.16	Set Tare range
	F1.17	Set Init Zero
	F1.18	Overload range
	F1.19	Set use Key Lock
	F1.20	Set F1 Key Use Type
	F1.21	Set F2 Key Use Type
	F1.22	Set F3 Key Use Type
	F1.23	Near Zero(Print, Relay)

Classification	Menu	SubMenu
<b>2. Communication Setting (2. COMM)</b>	<b>F2.01</b>	<b>Set Device ID</b>
	<b>F2.02</b>	<b>Set Data Transmission Rate</b>
	<b>F2.03</b>	<b>Set COM1 Port Setting</b>
	<b>F2.04</b>	<b>Set COM1 Baud Rate</b>
	<b>F2.05</b>	<b>Set COM1 Out Data</b>
	<b>F2.06</b>	<b>Set COM1 Output Format</b>
	<b>F2.07</b>	<b>Set COM1 Output mode</b>
	<b>F2.08</b>	<b>Set COM2 Port Setting</b>
	<b>F2.09</b>	<b>Set COM2 Baud Rate</b>
	<b>F2.10</b>	<b>Set COM2 Out Data</b>
	<b>F2.11</b>	<b>Set COM2 Output Format</b>
	<b>F2.12</b>	<b>Set COM2 Output mode</b>
	<b>F2.13</b>	<b>Set RS-422/485 Port Setting</b>
	<b>F2.14</b>	<b>Set RS-422/485 Baud Rate</b>
	<b>F2.15</b>	<b>Set RS-422/485 Out Data</b>
	<b>F2.16</b>	<b>Set RS-422/485 Output Format</b>
	<b>F2.17</b>	<b>Set RS-422/485 Output mode</b>

Classification	Menu	SubMenu
<b>3. Print Function (3. PRINT)</b>	<b>F3.01</b>	<b>Print Type</b>
	<b>F3.02</b>	<b>Print Form</b>
	<b>F3.03</b>	<b>Manage Print Data</b>
	<b>F3.04</b>	<b>Print Line Feed</b>
	<b>F3.05</b>	<b>Print Head Message</b>
	<b>F3.06</b>	<b>Print Delay Time</b>
	<b>F3.07</b>	<b>Print Condition</b>
	<b>F3.08</b>	<b>Print Set Automatic</b>
	<b>F3.09</b>	<b>Print Count Number</b>

Classification	Menu	SubMenu
<b>4. Option Setting (4. OPTION)</b>	<b>F4.01</b>	<b>Adjust Zero(Aout)</b>
	<b>F4.02</b>	<b>Adjust Span(Aout)</b>
	<b>F4.03</b>	<b>Max Weight(Aout)</b>
	<b>F4.04</b>	<b>BCD Out Type</b>

Classification	Menu	SubMenu
<b>5. Device Function (5. DEV)</b>	<b>F5.01</b>	<b>Set value Initialize</b>
	<b>F5.02</b>	<b>Set Date</b>
	<b>F5.03</b>	<b>Set Time</b>
	<b>F5.04</b>	<b>Set Password</b>



Classification		Menu	SubMenu
<b>6. Relay Setting (6. EXT)</b>	<b>All models</b>	<b>F6.01</b>	<b>Set Ext Input (Standard)</b>
		<b>F6.02</b>	<b>Set Ext Input (Option)</b>
	<b>CI-405 CI-407</b>	<b>F6.03</b>	<b>Relay Out mode</b>
		<b>F6.04</b>	<b>F_Relay Delay Start time</b>
		<b>F6.05</b>	<b>F_Relay Delay Operating</b>
		<b>F6.06</b>	<b>C_Relay Delay Start time</b>
		<b>F6.07</b>	<b>C_Relay Delay Operating</b>
		<b>F6.08</b>	<b>NG_Relay Delay operating</b>
	<b>CI-405</b>	<b>F6.09</b>	<b>Relay Operating Range</b>
		<b>F6.10</b>	<b>Delay Time of Start</b>
		<b>F6.11</b>	<b>Restart Delay time</b>
		<b>F6.12</b>	<b>Start Condition_Pack_M1</b>
	<b>CI-407</b>	<b>F6.08</b>	<b>NG_Relay Delay Start time</b>
<b>F6.09</b>		<b>NG_Relay Delay operating</b>	
<b>F6.10</b>		<b>Relay Operating Range</b>	
<b>F6.13</b>		<b>Start Condition_Pack_M1</b>	

# 1) General Function

## Menu-F1.01: Set AD Speed

Function	AD Speed Setting	
	Display Part	Meaning
Set Range (0~8)	1-01. 0	Converting speed 5 times per second
	<b>1-01. 1</b>	Converting speed 10 times per second
	1-01. 2	Converting speed 20 times per second
	1-01. 3	Converting speed 40 times per second
	1-01. 4	Converting speed 100 times per second
	1-01. 5	Converting speed 160 times per second
	1-01. 6	Converting speed 320 times per second
	1-01. 7	Converting speed 800 times per second
	1-01. 8	Converting speed 1600 times per second

Reference 1. After changing the AD speed, press   to display the weight using the altered value.

 (Press  after checking the changed value to return to the previous mode)

## Menu-F1.02: Set average filter`

Function	Average filter Setting	
	Display Part	Meaning
Set Range (1 ~ 50)	1-02 : XX <b>Initial Value : 10</b>	Setting the number of buffers in the average filter

Reference 1. Set based on the environment. (The rate of change of weight may slow)

## Menu-F1.03: Set Low Pass Filter

Function	Low Pass Filter Setting	
	Display Part	Meaning
Set Range (0 ~ 1)	1-03 : XX <b>Initial Value : 0</b>	Low Pass Filter use setting. (0: Not use, 1: Use)
Set Range (2 ~ 4)	F-od.XX <b>Initial Value : 2</b>	Low Pass Filter Degree setting.
Set Range (1 ~ 1600)	C-FfEq <b>Initial Value : 10</b>	Low Pass Filter Frequency setting

Reference 1. Uses the LPF (Low Pass Filter). The LPF order and LPF frequency setting menus are only displayed in this mode.

Reference 2. When using LPF, set according to the environment.

## Menu-F1.04: Set Band Stop Filter

Function	Band Stop Filter Setting	
	Display Part	Meaning
Set Range (0 ~ 1)	1-04 : XX <b>Initial Value : 0</b>	Band Stop Filter use setting. (0: Not use, 1: Use)
Set Range (1 ~ 1600)	H-FrEq <b>Initial Value : 60</b>	Band Stop Filter High Frequency setting..
Set Range (1 ~ 1600)	L-FrEq <b>Initial Value : 10</b>	Band Stop Filter Low Frequency setting..

Reference 1. Uses BSP (Band Stop Filter). The BSP High Frequency, BSP Low Frequency setting menus are only displayed in this mode.

Reference 2. When using BSP, set according to the environment.

## Menu-F1.06: Set Stable Weight Range

Function	Stable Weight Range Setting	
	Display Part	Meaning
Set Range (0 ~ 99)	1-06. XX <b>Initial Value : 1x 0.5 division</b>	Stability lamp is turned ON when weight change is such that the width of change in a given time is within the set value x 0.5 division

Reference 1. This function verifies the stable status when the weight fluctuation does not exceed 0.5x the readability setting within the set time.

Reference 2. The number should be made large and small for high-vibration and low-vibration environments respectively to quickly stabilize the weighing status.

## Menu-F1.07: Set Automatic Zero-set Range

Function	Automatic Zero-set Range Setting	
	Display Part	Meaning
Set Range (0 ~ 99)	1-07. XX <b>Initial Value : 1x 0.5 division</b>	Stability lamp is turned ON when weight change is such that the width of change in a given time is within the set value x 0.5 division

Reference 1. This function automatically corrects the zero-set if the weight does not exceed a set readability range within a set time when at zero-set state.

Ex) If the MENU [F1-07] is set to "2" when the maximum labeled increment is 120.0kg and the value of a single increment is 0.05kg

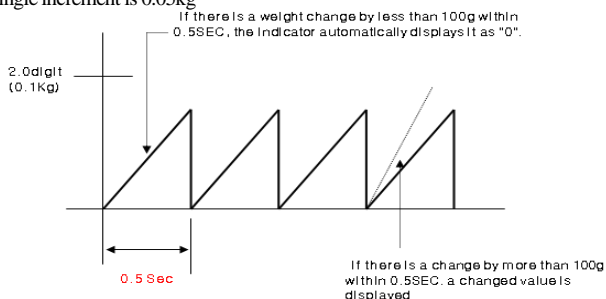

### Menu-F1.08: Set Weight Back-up

Function	Weight Back-up Setting	
Set Range (0, 1)	Display Part	Meaning
	<b>1-08. 0</b>	Weight back up function is not used
	1-08. 1	Weight back up is used (based on operation)

### Menu-F1.09: Set Hold Type

Function	Hold Type Setting	
Set Range (0~3)	Display Part	Meaning
	<b>1-9.00</b>	Average Value Hold
	1-9.01	Peak Hold
	1-9.02	Sampling Hold
	1-9.03	Automatic Hold

### Menu-F1.10: Set Average hold time

Function	Average hold time Setting	
Set Range (00~99)	Display Part	Meaning
	1-10. XX	Average value within the set value x sec is calculated
	<b>Initial Value : 30</b>	

### Menu-F1.11: Set Hold Canceling Conditions

Function	Hold Canceling Conditions Setting	
Set Range (0~2)	Display Part	Meaning
	<b>1-11.00</b>	Hold is canceled when it becomes zero
	1-11.01	Hold is canceled when Hold key is entered
	1-11.02	Hold is canceled when Hold less key entered

### Menu-F1.12: Set Automatic Hold Starting Conditions

Function	Automatic Hold Starting Conditions Setting	
Set Range (2~99)	Display Part	Meaning
	1-12. XX	Hold Starts when the weight changes within the set range value x 1 division
	<b>Initial Value : 10</b>	

### Menu-F1.13: Set Automatic Hold Canceling Conditions

Function	Automatic Hold Canceling Conditions Setting	
Set Range (00 ~ 99)	Display Part	Meaning
	1-13. XX <b>Initial Value : 10</b>	Hold is canceled when the value is changed by more Than 00 % of the hold value

### Menu-F1.14: Set Key Operating Conditions

Function	Key Operating Conditions(Zero, Tare) Setting	
Set Range (0, 1)	Display Part	Meaning
	1-14. 0	Always in operation
	<b>1-14. 1</b>	Operates only if the weight is stable

### Menu-F1.15: Set Zero Key Range

Function	Zero Key Range Setting	
Set Range (1~99)	Display Part	Meaning
	1-15. XX <b>Initial Value : 10 %</b>	Zero operates up to within +/- 00% of the maximum weight

### Menu-F1.16: Set Tare Key Range

Function	Tare Key Range Setting	
Set Range (1~100)	Display Part	Meaning
	1-16. XX <b>Initial Value : 100 %</b>	Tare operates up to within +/- 00% of the maximum weight

### Menu-F1.17: Set Initial Zero Range

Function	Initial Zero Range Setting	
Set Range (1~99)	Display Part	Meaning
	1-17. XX <b>Initial Value : 10%</b>	Initial zero operates within +/- 00% of the Gross Weight

### Menu-F1.18: Set Overload Range

Function	Overload Range Setting	
Set Range (1~99)	Display Part	Meaning
	1-18. XX <b>Initial Value : 9 x 1 Digit</b>	Overweight from the next to 0 x 1 Digit of the maximum weight

### Menu-F1.19: Set use Key Lock

Function	Key Lock use Setting	
Set Range (0, 1)	Display Part	Meaning
	<b>1-19.0</b>	Unlock front key
	1-19.1	Lock front key

### Menu-F1.20: Set F1 Key Use Type

Function	F1 Key Use Type Setting	
Set Range (0~14)	Display Part	Meaning
	<b>1-20.00</b>	F1 Key used as the tare/tare cancelling key
	1-20.01	F1 Key used as the total/net weight key
	1-20.02	F1 Key used as the Hold key
	1-20.03	F1 Key used as the Holdless key
	1-20.04	F1 Key used as the Tare key
	1-20.05	F1 Key used as the Cleaning key
	1-20.06	F1 Key used as the Tare cancelling key
	1-20.07	F1 Key used as the Set Point 1 key
	1-20.08	F1 Key used as the Set Point 2 key
	1-20.09	F1 Key used as the Set Point 3 key
	1-20.10	F1 Key used as the Set Point 4 key
	1-20.11	F1 Key used as the Set Point 5 key
	1-20.12	F1 Key used as the Set Point 6 key
1-20.13	F1 Key used as the Start key	
1-20.14	F1 Key used as the Stop key	

### Menu-F1.21: Set F2 Key Use Type

Function	F2 Key Use Type Setting	
Set Range (0~14)	Display Part	Meaning
	1-21.00	F2 Key used as the tare/tare cancelling key
	<b>1-21.01</b>	F2 Key used as the total/net weight key
	1-21.02	F2 Key used as the Hold key
	1-21.03	F2 Key used as the Holdless key
	1-21.04	F2 Key used as the Tare key
	1-21.05	F2 Key used as the Cleaning key
	1-21.06	F2 Key used as the Tare cancelling key
	1-21.07	F2 Key used as the Set Point 1 key
	1-21.08	F2 Key used as the Set Point 2 key
	1-21.09	F2 Key used as the Set Point 3 key
	1-21.10	F2 Key used as the Set Point 4 key
	1-21.11	F2 Key used as the Set Point 5 key
	1-21.12	F2 Key used as the Set Point 6 key
1-21.13	F2 Key used as the Start key	
1-21.14	F2 Key used as the Stop key	

### Menu-F1.22: Set F3 Key Use Type

Function	F3 Key Use Type Setting	
Set Range (0~14)	Display Part	Meaning
	1-22.00	F3 Key used as the tare/tare cancelling key
	1-22.01	F3 Key used as the total/net weight key
	<b>1-22.02</b>	F3 Key used as the Hold key
	1-22.03	F3 Key used as the Holdless key
	1-22.04	F3 Key used as the Tare key
	1-22.05	F3 Key used as the Cleaning key
	1-22.06	F3 Key used as the Tare cancelling key
	1-22.07	F3 Key used as the Set Point 1 key
	1-22.08	F3 Key used as the Set Point 2 key
	1-22.09	F3 Key used as the Set Point 3 key
	1-22.10	F3 Key used as the Set Point 4 key
	1-22.11	F3 Key used as the Set Point 5 key
	1-22.12	F3 Key used as the Set Point 6 key
1-22.13	F3 Key used as the Start key	
1-22.14	F3 Key used as the Stop key	

### Menu-F1.23: Set Near Zero(Print, Relay)

Function	Set Near Zero(Print, Relay)	
Set Range (0~99)	Display Part	Meaning
	1-23.0 x 1 Digit <b>Initial Value:</b> <b>0x 1 Digit</b>	Up to the set value * 1 Digit is allowed as the zero

## 2) Communication Setting

### Menu-F2.01: Equipment Number

Function	Equipment Number	
Set Range (0 ~ 99)	Display Part	Meaning
	2-01. XX <b>Initial Value : 0</b>	Desired device ID may be entered.

Reference 1. This function can be used as the indicator unique ID when using COMMAND mode.

### Menu-F2.02: Data Transfer Speed Setting

Function	Data Transfer Speed Setting	
Set Range (0 ~ 9999)	Display Part	Meaning
	XXXX <b>Initial Value : 50x10ms</b>	Data are transmitted by the unit of 00 x 10ms

Reference 1. When set to "0", data is transferred in real-time.

### Menu-F2.03: Set COM1 Port

Function	Com1 RS-232C Port Setting	
Set Range (0~5)	Display Part	Meaning
	<b>2-03. 0</b>	Data Bit 8, Stop Bit 1, Parity Bit : None
	2-03. 1	Data Bit 7, Stop Bit 1, Parity Bit: Even
	2-03. 2	Data Bit 7, Stop Bit 1, Parity Bit: Odd
	2-03. 3	Data Bit 7, Stop Bit 2, Parity Bit: Odd
	2-03. 4	Data Bit 8, Stop Bit 1, Parity Bit: Even
2-03. 5	Data Bit 8, Stop Bit 1, Parity Bit: Odd	

### Menu-F2.04: Set COM1 Baud Rate

Function	COM1 RS-232C Baud Rate Setting	
Set Range (0 ~ 7)	Display Part	Meaning
	2-04. 0	1,200 bps
	2-04. 1	2,400 bps
	2-04. 2	4,800 bps
	<b>2-04. 3</b>	9,600 bps
	2-04. 4	19,200 bps
	2-04. 5	38,400 bps
	2-04. 6	57,600 bps
2-04. 7	115,200 bps	

## Menu-F2.05: Set COM1 Out Data

Function	COM1 RS-232C Out Data Setting	
	Display Part	Meaning
Set Range (0 ~ 2)	<b>2-05. 0</b>	Displayed value is transmitted
	2-05. 1	Gross Weight is transmitted
	2-05. 2	Net weight is transmitted

## Menu-F2.06: COM1 Output Format

Function	COM1 RS-232C Output Format	
	Display Part	Meaning
Set Range (0 ~ 3)	<b>2-06. 0</b>	22 byte of CAS
	2-06. 1	10 byte of CAS
	2-06. 2	18 byte Format(AND, FINE)
	2-06. 3	22 byte of CAS with relay status

Reference 1. Refer to <Appendix 1> for the communication format

## Menu-F2.07: COM1 Communication Method

Function	COM1 Communication Method (RS-232C - Output mode)	
	Display Part	Meaning
Set Range (0 ~ 8)	<b>2-07. 0</b>	Data is not transmitted
	2-07. 1	Transmitted only if the print key is pushed
	2-07. 2	Transmitted in both stable/unstable cases (Stream Mode)
	2-07. 3	Transmitted only if the weight is stable
	2-07. 4	Command Type 1
	2-07. 5	Command Type 2
	2-07. 6	Command Type 3
	2-07. 7	Transmitted only upon completion signal
	2-07. 8	Modbus protocol

Reference 1. Refer to Appendix 2, 3 and 4 for command types.

## Menu-F2.08: Set COM2 Port

Function	COM2 RS-232C Port Setting	
	Display Part	Meaning
Set Range (0 ~ 5)	<b>2-08. 0</b>	Data Bit 8, Stop Bit 1, Parity Bit : None
	2-08. 1	Data Bit 7, Stop Bit 1, Parity Bit: Even
	2-08. 2	Data Bit 7, Stop Bit 1, Parity Bit: Odd
	2-08. 3	Data Bit 7, Stop Bit 2, Parity Bit: Odd
	2-08. 4	Data Bit 8, Stop Bit 1, Parity Bit: Even
	2-08. 5	Data Bit 8, Stop Bit 1, Parity Bit: Odd

### Menu-F2.09: Set COM2 Baud Rate

Function	COM2 RS-232C Baud Rate Setting	
Set Range (0~7)	Display Part	Meaning
	2-09. 0	1,200 bps
	2-09. 1	2,400 bps
	2-09. 2	4,800 bps
	<b>2-09. 3</b>	9,600 bps
	2-09. 4	19,200 bps
	2-09. 5	38,400 bps
	2-09. 6	57,600 bps
2-09. 7	115,200 bps	

### Menu-F2.10: Set COM2 Out Data

Function	COM2 RS-232C Out Data Setting	
Set Range (0~2)	Display Part	Meaning
	<b>2-10. 0</b>	Displayed value is transmitted
	2-10. 1	Gross Weight is transmitted
	2-10. 2	Net weight is transmitted

### Menu-F2.11: COM2 Output Format

Function	COM2 RS-232C Output Format	
Set Range (0~3)	Display Part	Meaning
	<b>2-11. 0</b>	22 byte of CAS
	2-11. 1	10 byte of CAS
	2-11. 2	18 byte Format(AND, FINE)
	2-11. 3	22 byte of CAS with relay status

Reference 1. Refer to <Appendix 1> for the communication format

## Menu-F2.12: COM2 Communication Method

Function	COM2 Communication Method (RS-232C - Output mode)	
Set Range (0 ~ 8)	Display Part	Meaning
	<b>2-12. 0</b>	Data is not transmitted
	2-12. 1	Transmitted only if the print key is pushed
	2-12. 2	Transmitted in both stable/unstable cases (Stream Mode)
	2-12. 3	Transmitted only if the weight is stable
	2-12. 4	Command Type 1
	2-12. 5	Command Type 2
	2-12. 6	Command Type 3
	2-12. 7	Transmitted only upon completion signal
2-12. 8	Modbus protocol	

Reference 1. Refer to Appendix 2, 3 and 4 for command types.

## Menu-F2.13: Set RS-422/485 Port

Function	RS-422/485 Port Setting	
Set Range (0 ~ 5)	Display Part	Meaning
	<b>2-13. 0</b>	Data Bit 8, Stop Bit 1, Parity Bit : None
	2-13. 1	Data Bit 7, Stop Bit 1, Parity Bit: Even
	2-13. 2	Data Bit 7, Stop Bit 1, Parity Bit: Odd
	2-13. 3	Data Bit 7, Stop Bit 2, Parity Bit: Odd
	2-13. 4	Data Bit 8, Stop Bit 1, Parity Bit: Even
2-13. 5	Data Bit 8, Stop Bit 1, Parity Bit: Odd	

## Menu-F2.14: Set RS-422/485 Baud Rate

Function	RS-422/485 Baud Rate Setting	
Set Range (0 ~ 7)	Display Part	Meaning
	2-14. 0	1,200 bps
	2-14. 1	2,400 bps
	2-14. 2	4,800 bps
	<b>2-14. 3</b>	9,600 bps
	2-14. 4	19,200 bps
	2-14. 5	38,400 bps
	2-14. 6	57,600 bps
2-14. 7	115,200 bps	

### Menu-F2.15: Set RS-422/485 Out Data

Function	RS-422/485 Out Data Setting	
	Display Part	Meaning
Set Range (0~2)	2-15. 0	Displayed value is transmitted
	2-15. 1	Gross Weight is transmitted
	2-15. 2	Net weight is transmitted

### Menu-F2.16: RS-422/485 Output Format

Function	RS-422/485 Output Format	
	Display Part	Meaning
Set Range (0~3)	2-16. 0	22 byte of CAS
	2-16. 1	10 byte of CAS
	2-16. 2	18 byte Format(AND, FINE)
	2-16. 3	22 byte of CAS with relay status

Reference 1. Refer to <Appendix 1> for the communication format

### Menu-F2.17: RS-422/485 Communication Method

Function	RS-422/485 Communication Method (Output mode)	
	Display Part	Meaning
Set Range (0~8)	2-17. 0	Data is not transmitted
	2-17. 1	Transmitted only if the print key is pushed
	2-17. 2	Transmitted in both stable/unstable cases (Stream Mode)
	2-17. 3	Transmitted only if the weight is stable
	2-17. 4	Command Type 1
	2-17. 5	Command Type 2
	2-17. 6	Command Type 3
	2-17. 7	Transmitted only upon completion signal
	2-17. 8	Modbus protocol

Reference 1. Refer to Appendix 2, 3 and 4 for command types.

### 3) Print Function Setting

#### Menu-F3.01: Set Printer Type

Function	Set Printer Type	
Set Range (0~3)	Display Part	Meaning
	<b>3-01. 0</b>	Printer is not used
	3-01. 1	CAS DEP Ticket Print Standard Type
	3-01. 2	CAS DLP Label Print Standard Type
	3-01. 3	CAS BP Label Printer

#### Menu-F3.02: Set Print Form

Function	Set Print Form	
Set Range (0~5)	Display Part	Meaning
	<b>3-02. 0</b>	Print Form 1 (Date, Time, Serial No., Item No., Net Weight) BP Print Form 1(FORM1)
	3-02. 1	Print Form 2 (Date, Time, Weighing No., Net Weight) BP Print Form 2(FORM2)
	3-02. 2	Print Form 3 (Date, Time, Gross Weight, Tare, Net Weight) BP Print Form 3(FORM3)
	3-02. 3	Print Form 4 (Date, Time, Net Weight) BP Print Form 4(FORM4)
	3-02. 4	Print Form 5 (Date, Time, Item No., Net Weight) BP Print Form 5(FORM5)
	3-02. 5	Print Form 6 (Date, Time, Serial No., Net Weight) BP Print Form 6(FORM6)

##### 【 Form 1 】

Date, Time, Serial No., Item No.,  
Net Weight

2009.07.07[TUE]	12:30:46
1, ID_11,	50.0kg
2, ID_12,	100.0kg
3, ID_19,	200.5kg

##### 【 Form 2 】

Date, Time, Weighing No.,  
Net Weight

2009.07.07[TUE]	12:30:46
No. 1	50.0kg
No. 2	100.0kg
No. 3	200.5kg

##### 【 Form 3 】

Date, Time, Gross Weight, Tare,  
Net Weight

2009.07.07[TUE]	12:30:46
Gross:	1000.0kg
Tare :	0.0kg
Net :	1000.0kg
Gross:	2000.0kg
Tare :	500.0kg
Net :	1500.0kg

##### 【 Form 4 】

Date, Time, Net Weight

2009.07.07[TUE]	12:30:46
10:10:30	Net: 50.0kg
11:00:32	Net: 100.0kg
12:30:34	Net: 200.5kg

##### 【 Form 5 】

Date, Time, Item No.,  
Net Weight

2009.07.07[TUE]	12:30:46
ID_11,	Net: 50.0kg
ID_12,	Net: 100.0kg
ID_19,	Net: 200.5kg

##### 【 Form 6 】

Date, Time, Serial No.,  
Net Weight

2009.07.07[TUE]	12:30:46
1,	1000.0kg
2009.07.07[TUE]	12:32:56
2,	200.5kg

CAS DLP Protocol

Parameter	Description	Data Length
V00	Gross Weight	7 byte
V01	Tare Value	7 byte
V02	Net Weight	7 byte
V03	Barcode (net weight)	6 byte
V04	Item Number	2 byte
V05	Item Name	10 byte
V06	Print count	3 byte
V07	Date	10 byte
V08	Time	8 byte

CAS BP Series Printer Protocol

Parameter	Description	Data Length
V00	Gross Weight	7 byte
V01	Tare Value	7 byte
V02	Net Weight	7 byte
V03	Net (': omit) : for bar code	6 byte
V04	Item Number	2 byte
V05	Item Name	10 byte
V06	Print count	3 byte
V07	Date	10 byte
V08	Time	8 byte
V09	Unit(kg)	2 byte
V10	Total Net (': include)	9 byte
V11	Preset Tare	7 byte

### Menu-F3.03: Manage Print Data



Function	Manage Print Data	
Set Range (0 ~ 1)	Display Part	Meaning
	<b>3-03. 0</b>	Accumulated value is cleared upon printing
	3-03. 1	Cleared when the clearing key is pushed



### Menu-F3.04: Set Print Line feed

Function	Set Print Line feed	
Set Range (0~9)	Display Part	Meaning
	3-04. 1	Set a spacing between lines as the set value upon printing
	<b>Initial Value: 1</b>	

### Menu-F3.05: Set Print Head Message

Function	Set Print Head Message	
Set Range (32 ~ 255)	Display Part	Meaning
	12 - 065	Designate a character "A" equivalent to ASCII code 65 in the 12th data
	00 - 032	To print out the added contents, designate ASCII code 32 to 0th data.
	18 - 255	The end has to be meant by designating ASCII code 255 next to the last data.

 : number settings,,
  : coordinate increase,

 : coordinate decrease,
  : input complete

Reference 1. This function adds the desired content to the print format. (e.g.: company name, phone number)

Reference 2. Coordinates capable of being designated are from 0 to 71. From these, the 0th data determines whether to print the additional content (032: print, all others: do not print) and everything is printed from data 1 until data 255.

Reference 3. To add company name "CAS" to the existing print format, designate as follows

P00-032 (ASCII code 32: data starts),  
 P01-067 (ASCII code 67: character C)  
 P02-065 (ASCII code 65: character A)  
 P03-083 (ASCII code 83: character S)  
 P04-255 (ASCII code 255: data ends)

### Menu-F3.06: Set Printing Delay Time

Function	Set Printing Delay Time	
Set Range (0 ~ 200)	Display Part	Meaning
	3-06. 1	Issue print after 00 x 10ms
	<b>Initial Value: 1</b>	

### Menu-F3.07: Set Print Condition

Function	Set Print Condition	
Set Range (0 ~ 2)	Display Part	Meaning
	<b>3-07. 0</b>	Print out only if the weight value is +
	3-07. 1	Print out only if the weight value is -
	3-07. 2	Print out regardless of whether the weight value is +/-

### Menu-F3.08: Set Print Out Condition

Function	Set Print Out Condition (Printing condition)	
Set Range (0 ~ 1)	Display Part	Meaning
	<b>3-08. 0</b>	Printed only if the print key is pushed
	3-08. 1	Printed automatically if the weight value is stabilized

### Menu-F3.09: Print Count Number

Function	Print Count Number	
Set Range (0 ~ 1)	Display Part	Meaning
	3-09. 0	Fixed
	<b>3-09. 1</b>	Printing times are increased automatically by one at a time after weighing operation

## 4) Option Setting

### Menu-F4.01: Adjust zero of A-out

Function	Adjust the Zero Output upon Using Analog Out option	
	Display Part	Meaning
Set Range (0 ~ 24000)	0000	0.000mA, 0V output
	<b>4000</b>	4.000mA, 2V output
	4015	4.015mA, 2.007V output

### Menu-F4.02: Adjust Span of A-out

Function	Adjust the Maximum Output upon Using Analog Out option	
	Display Part	Meaning
Set Range (0 ~ 24000)	10000	10.000 mA, 4.16 V output
	<b>20000</b>	20.000 mA, 8.33 V output
	24000	24.000 mA, 10.0 V output

### Menu-F4.03: Maximum weight of A-out

Function	Maximum Output Weight Value upon Using Analog Out option	
	Display Part	Meaning
Set Range (0 ~ Max weight)	1000	Maximum output at 1000 kg Maximum output at 2000 kg
	2000	
	<b>Initial value : Max weight</b>	

### Menu-F4.04: BCD Out Type

Function	BCD Out Type	
	Display Part	Meaning
Set Range (1~2)	<b>4-04. 0</b>	Bcd out set to positive logic
	4-04. 1	Bcd out set to negative logic

## 5) Hardware Set Function

### Menu-F5.01: Set Value Initialization

Function	Set Value Initialization	
Set Range (0, 1)	Display Part	Meaning
	5-01. 0	No set values of the product are initialized to factory shipping state
	5-01. 1	All set values of the product are initialized to factory shipping state

### Menu-F5.02: Set Date

Function	Set Date	
Number Key	Display Part	Meaning
: Data Designation	10.08.17	August 17th, 2010

### Menu-F5.03: Set Time

Function	Set Time	
Number Key	Display Part	Meaning
: Data Designation	11.30.10	30 minutes and 10seconds past 11 o'clock

### Menu-F5.04: Set Password

Function	Set Password	
Set Range (0, 1)	Display Part	Meaning
	5-04. 0	Password entry is not used upon entering the setting mode
	5-04. 1	Password entry is used upon entering the setting mode

Function	Set Password	
Set Range (0 ~ 9999)	Display Part	Meaning
	XXXX	4-digit number entered is used as the password

## 6) Relay Setting

**CI-401** : Menu-F6.01

**CI-405** : Menu-F6.01 ~ F6.12(Relay Output Setting : 62p)

**CI-407** : Menu-F6.01 ~ F6.13(Relay Output Setting : 78p)

\*Menu-F6.02 ~ : Relay Option Card Setting Menu.

### Menu-F6.01: Set External key

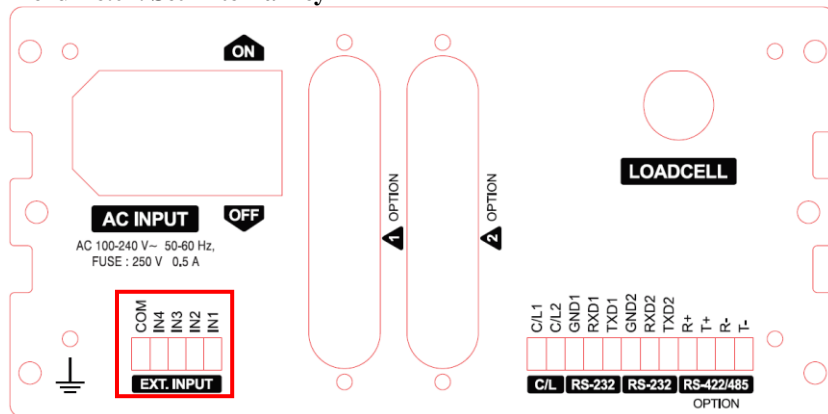

Function	Set External key				
Set Range (0~9)	Display Part	<b>Input1</b>	<b>Input2</b>	<b>Input3</b>	<b>Input4</b>
	<b>6-01. 0</b>	<b>ZERO</b>	<b>TARE</b>	<b>TARE_C</b>	<b>PRINT</b>
	6-01. 1	ZERO	TARE/C	HOLD	HOLD_C
	6-01. 2	ZERO	TARE/C	I-SUM	PRINT
	6-01. 3	ZERO	HOLD	HOLD_C	PRINT
	6-01. 4	ZERO	I-SUM	G-SUM	PRINT
	6-01. 5	ZERO	TARE	TARE_C	G/N
	6-01. 6	ZERO	TARE/C	VERDIC	PRINT
	6-01. 7	ZERO	PRINT	START	STOP
	6-01. 8	START	STOP	HOLD	G/N
6-01. 9	TARE	PRINT	START	STOP	

TARE\_C = Tare Clear

TARE/C = Toggle key Tare / Tare Clear

HOLD\_C = Hold Clear

G/N = Gross / Net change key

## Relay Option Card Setting (CI-405, CI-407)

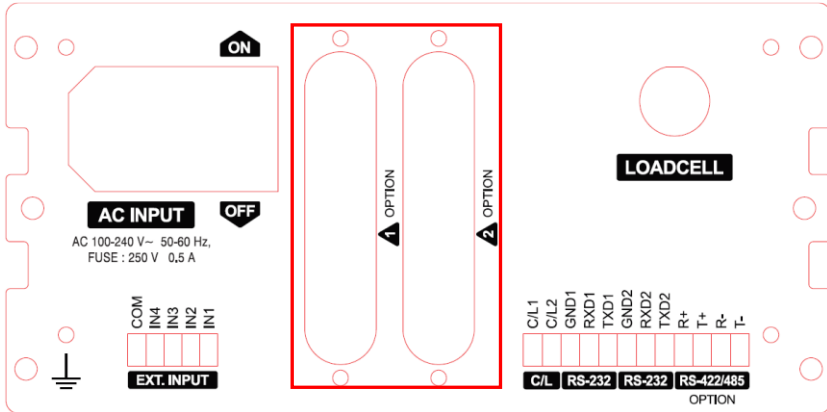

### Menu-F6.02: Set External key

Function	Set External key				
	Display Part	Input1	Input2	Input3	Input4
Set Range (0~9)	6-02. 0	ZERO	TARE	TARE_C	PRINT
	6-02. 1	ZERO	TARE/C	HOLD	HOLD_C
	6-02. 2	ZERO	TARE/C	I-SUM	PRINT
	6-02. 3	ZERO	HOLD	HOLD_C	PRINT
	6-02. 4	ZERO	I-SUM	G-SUM	PRINT
	6-02. 5	ZERO	TARE	TARE_C	G/N
	6-02. 6	ZERO	TARE/C	VERDIC	PRINT
	6-02. 7	ZERO	PRINT	START	STOP
	6-02. 8	START	STOP	HOLD	G/N
6-02. 9	TARE	PRINT	START	STOP	

TARE\_C = Tare Clear

TARE/C = Toggle key Tare / Tare Clear

HOLD\_C = Hold Clear

G/N = Gross / Net change key

## CI-405 Relay Output Setting

### Menu-F6.03: Relay Mode

Function	Relay Mode	
Set Range (0~11)	Display Part	Meaning
	<b>6-03. 0</b>	<b>Limit Mode 1 (Step 4 Contact Point A Output)</b>
	6-03. 1	Limit Mode 2 (Fall and Weighing Decision)
	6-03. 2	Packer Mode 1 (Step4 Contact Point B Output)
	6-03. 3	Packer Mode 2 (Fall and Weighing Decision)
	6-03. 4	Checker Mode 1 (Step 5 Decision upon Weight Stabilization)
	6-03. 5	Checker Mode 2 (Step 3 Decision upon Weight Stabilization)
	6-03. 6	Checker Mode 3 (Weight Level)
	6-03. 7	Checker Mode 4 (Indentation Management)
	6-03. 8	Checker Mode 5 (Weight Sorting)
	6-03. 9	Auto Tare Packer Mode
	6-03. 10	Auto Tare Auto Packer Mode (Auto start)
6-03. 11	Auto Zero Auto Packer Mode (Auto start)	

### Set Point Mapping Information per Mode

Relay Mode	SP 1	SP 2	SP 3	SP 4	SP 5	SP 6
0_Limit Mode1	Step 1	Step 2	Step 3	Step 4		
1_Limit Mode2	Step 1	Step 2	Step 1 Fall Value	Step 2 Fall Value	Upper Limit Fall Value	Lower Limit Fall Value
2_Packer Mode1	Step 1	Step 2	Step 3	Step 4		
3_Packer Mode2	Step 1	Step 2	Step 1 Fall Value	Step 2 Fall Value	Upper Limit Fall Value	Lower Limit Fall Value
4_Checker Mode1	Step 1	Step 2	Step 3	Step 4		
5_Checker Mode2	Step 1 (LOW)	Step 2 (HIGH)				
6_Checker Mode3	Step 1	Step 2	Step 3	Step 4		
7_Checker Mode4	Step 1 (LOW)	Step 2 (HIGH)				
8_Checker Mode5	Step 1 (LOW)	Step 2 (HIGH)				
9_Auto Tare Packer Mode.	Step 1	Step 2	Step 1 Fall Value	Step 2 Fall Value	Upper Limit Fall Value	Lower Limit Fall Value
10_Auto Tare Auto Packer Mode	Step 1	Step 2	Step 1 Fall Value	Step 2 Fall Value	Upper Limit Fall Value	Lower Limit Fall Value
11_Auto Zero Auto Packer Mode	Step 1	Step 2	Step 1 Fall Value	Step 2 Fall Value	Upper Limit Fall Value	Lower Limit Fall Value

Note 1. See the above Table for Set Point Values applied for each weighing per mode

### Weighing Output Information per Mode

Relay Mode	OUT 1	OUT 2	OUT 3	OUT 4	OUT 5	OUT 6
0_Limit Mode1	Step 1 (SP1 ≤ W)	Step 2 (SP2 ≤ W)	Step 3 (SP3 ≤ W)	Step 4 (SP4 ≤ W)	Completed	Zero
1_Limit Mode2	Step 1 (SP1-SP3 ≤ W)	Step 2 (SP2-SP4 ≤ W)	Completed	Lower Limit NG (W < SP2-SP6)	Upper Limit NG (SP2+SP5 < W)	Zero
2_Packer Mode1	Step 1 (W ≤ SP1)	Step 2 (W ≤ SP2)	Step 3 (W ≤ SP3)	Step 4 (W ≤ SP4)	Completed	Zero
3_Packer Mode2	Step 1 (W ≤ SP1-SP3)	Step 2 (W ≤ SP2-SP4)	Completed	Lower Limit NG (W < SP2-SP6)	Upper Limit NG (SP2+SP5 < W)	Zero
4_Checker Mode1	Step 1 (Z ≤ W < SP1)	Step 2 (SP1 ≤ W < SP2)	Step 3 (SP2 ≤ W < SP3)	Step 4 (SP3 ≤ W < SP4)	Above Step 4	Zero
5_Checker Mode2	Step1 : LOW (Z ≤ W < SP1)	Step2 : HIGH (SP2 ≤ W)	Step3 : OK (SP1 ≤ W < SP2)	Lower LimitNG (Z ≤ W < SP1)	Upper LimitNG (SP2 ≤ W)	Zero
6_Checker Mode3	Step 1 (Z ≤ W < SP1)	Step 2 (SP1 ≤ W < SP2)	Step 3 (SP2 ≤ W < SP3)	Step 4 (SP3 ≤ W < SP4)	Above Step4 (SP4 ≤ W)	Zero
7_Checker Mode4	Step1 : LOW (Z ≤ W < SP1)	Step2 : HIGH (SP2 ≤ W)	Step3 : OK (SP1 ≤ W < SP2)	Lower LimitNG (Z ≤ W < SP1)	Upper LimitNG (SP2 ≤ W)	Zero
8_Checker Mode5	Step1 : LOW (Z ≤ W < SP1)	Step2 : HIGH (SP2 ≤ W)	Step3 : OK (SP1 ≤ W < SP2)	Lower LimitNG (Z ≤ W < SP1)	Upper LimitNG (SP2 ≤ W)	Zero
9_Auto Tare Packer Mode	Step 1 (W ≤ SP1-SP3)	Step 2 (W ≤ SP2-SP4)	Completed	Lower Limit NG (W < SP2-SP6)	Upper Limit NG (SP2+SP5 < W)	Zero
10_Auto Tare Auto Packer Mode	Step 1 (W ≤ SP1-SP3)	Step 2 (W ≤ SP2-SP4)	Completed	Lower Limit NG (W < SP2-SP6)	Upper Limit NG (SP2+SP5 < W)	Zero
11_Auto Zero Auto Packer Mode	Step 1 (W ≤ SP1-SP3)	Step 2 (W ≤ SP2-SP4)	Completed	Lower Limit NG (W < SP2-SP6)	Upper Limit NG (SP2+SP5 < W)	Zero

### Menu-F6.04: F\_Relay Delay Start Time

Function	Set Start Delay Time for completed Relay(T1)	
Set Range (0~99)	Display Part	Meaning
	6-04. 10 <b>Initial Value:</b> 10 x 0.1 Sec	Delayed by 00 x 0.1 Sec

### Menu-F6.05: F\_Relay Operating Duration

Function	Set Operating Duration Time for completed Relay(T2)	
Set Range (0~99)	Display Part	Meaning
	6-05. 10 <b>Initial Value:</b> 10 x 0.1 Sec	Lasts for 00 x 0.1 Sec

### Menu-F6.06: C\_Relay Delay Start Time

Function	Set Start Delay Time for Decision Relay(T3)	
Set Range (0~99)	Display Part	Meaning
	6-06. 0 <b>Initial Value:</b> 0 x 0.1 Sec	Delayed by 00 x 0.1 Sec

### Menu-F6.07: C\_Relay Operating Duration

Function	Set Operating Duration Time for Decision Relay(T4)	
Set Range (0~99)	Display Part	Meaning
	6-07. 20 <b>Initial Value:</b> 20 x 0.1 Sec	Lasts for 00 x 0.1 Sec

### Menu-F6.08: NG\_Relay Operating Duration

Function	Set Operating Time for Weighing NG Relay(T5)	
Set Range (0~99)	Display Part	Meaning
	6-08. 20 <b>Initial Value:</b> 20 x 0.1 Sec	Lasts for 00 x 0.1 Sec

### Menu-F6.09: Relay Operating Range

Function	Relay Operating Range	
Set Range (0 ~ 2)	Display Part	Meaning
	<b>6-9. 0</b>	<b>Relay is operating in only +(weight) range</b>
	6-9. 1	Relay is operating in only -(weight) range
	6-9. 2	Relay is operating in +,-(weight) range

### Menu-F6.10: Delay Time of Start (Not Used Relay Type\_I)

Function	Set Delay time of start	
Set Range (0-99)	Display Part	Meaning
	6-10. 10	Delayed by 00 x 0.1 Sec
	<b>Initial Value: 10 x 0.1 Sec</b>	

### Menu-F6.11: Restart Delay Time

Function	Set Restart delay time (T6)	
Set Range (0-99)	Display Part	Meaning
	6-11. 10	Delayed by 00 x 0.1 Sec
	<b>Initial Value: 10 x 0.1 Sec</b>	

### Menu-F6.12: Start Condition\_Pack\_M1

Function	Start condition of Packer mode 1	
Set Range (0, 1)	Display Part	Meaning
	<b>6-12. 0</b>	<b>Relay start operating is only zero range</b>
	6-12. 1	Relay start operating is always

## ■ CI-405 Relay Timing graph

### <Limit mode 1> Relay Operation Graph upon Setting (F6.03-0)

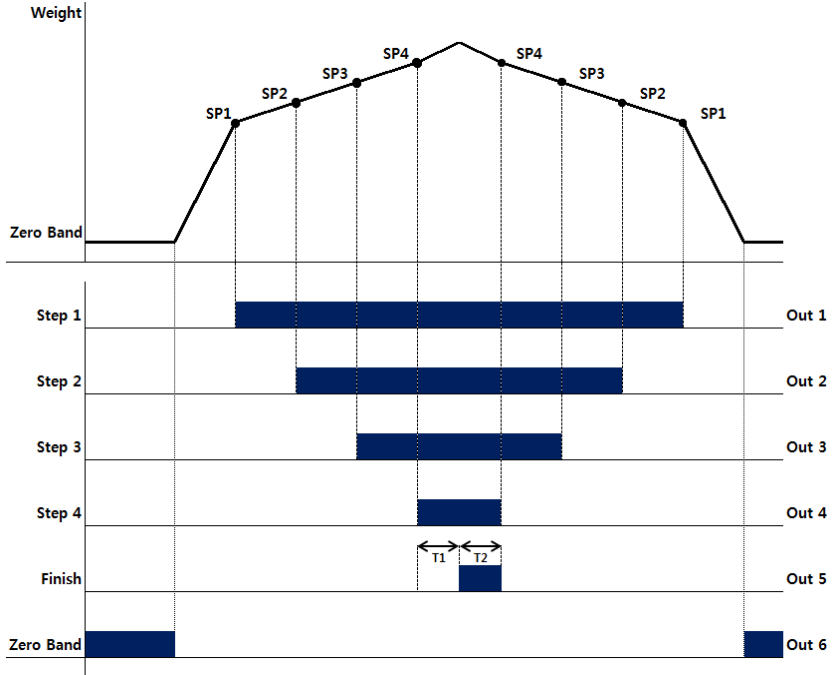

1. Required set value input :  $SP4 > SP3 > SP2 > SP1$
2. T1 : Refer to F6.04 (Delay time of weighing Finish relay output)  
T2 : Refer to F6.05 (Operation time of weighing Finish relay output)
3. Relay Output

Step1 : ON when $(SP1 \leq \text{Weight})$
Step2 : ON when $(SP2 \leq \text{Weight})$
Step3 : ON when $(SP3 \leq \text{Weight})$
Step4 : ON when $(SP4 \leq \text{Weight})$
Finish : ON after T1(set time), ON for the during of T2 (set time)
Near Zero : F1.23 set value $\geq \text{Weight} \geq 0$ range output

4. Status lamp in the front panel is operated in the same manner as the RELAY output.

### <Limit mode 2> Relay Operation Graph upon Setting (F6.03-1)

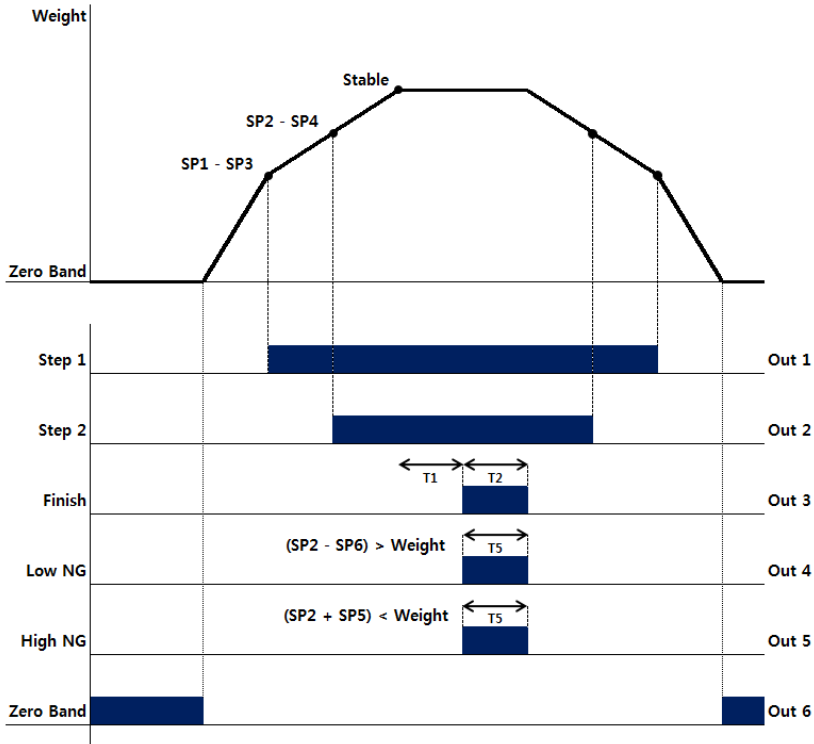

1. Set value input requirement :  $(SP2 - SP4) > (SP1 - SP3)$
2. T1 : Refer to F6.04 (Delay time of weighing Finish relay output)  
 T2 : Refer to F6.05 (Operation time of weighing Finish relay output)  
 T5 : Refer to F6.08 (Operation(ON) time of Weighing NG relay output)

3. Relay Output

Step1 : ON when $(SP1 - SP3) \leq \text{Weight}$
Step2 : ON when $(SP2 - SP4) \leq \text{Weight}$
Finish : On after T1 (set time), ON after T2 (set time)
Lowest Limit NG: ON when $\text{Weight} < (SP2 - SP6)$
Upper Limit NG: ON when $(SP2 + SP5) < \text{Weight}$
Near Zero : F1-23 set value $\geq \text{Weight} \geq 0$ range output

4. Status lamp in the front panel is operated in the same manner as the RELAY output

## <Packer Mode 1> Relay Operation Graph upon Setting (F6.03-2)

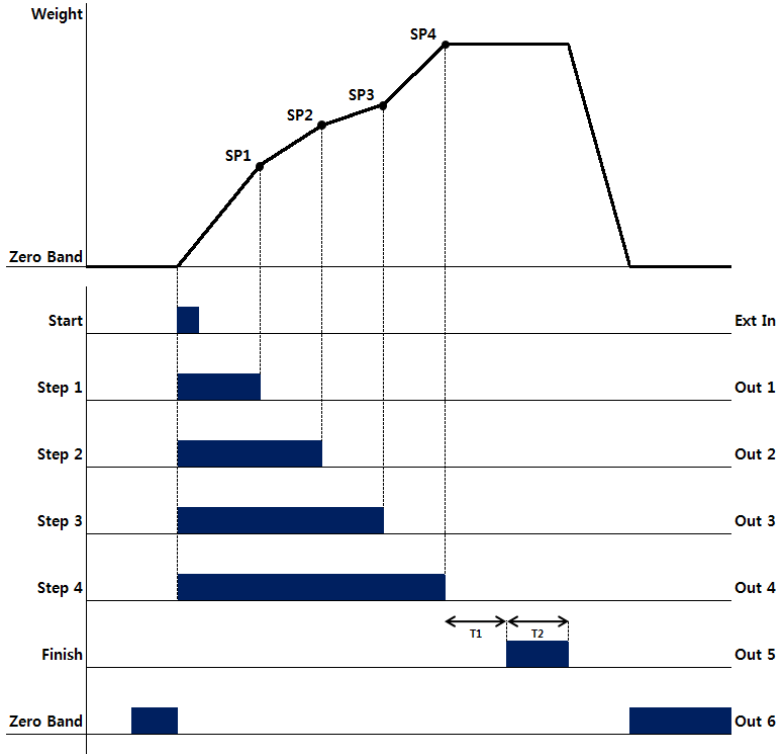

1. Required set value input :  $SP4 > SP3 > SP2 > SP1$
2. T1 : Refer to F6.04 (Delay time of weighing Finish relay output)  
T2 : Refer to F6.05 (Operation time of weighing Finish relay output)
3. Relay Output

Step1 : OFF when $(SP1 \leq \text{Weight})$
Step2 : OFF when $(SP2 \leq \text{Weight})$
Step3 : OFF when $(SP3 \leq \text{Weight})$
Step4 : OFF when $(SP4 \leq \text{Weight})$
Finish : ON after T1 (set time), ON for the during of T2 (set time)
Near Zero : F1.23 set value $\geq \text{Weight} \geq 0$ range output

4. Status lamp in the front panel is operated in the same manner as the RELAY output

## <Packer Mode 2> Relay Operation Graph upon Setting (F6.03-3)

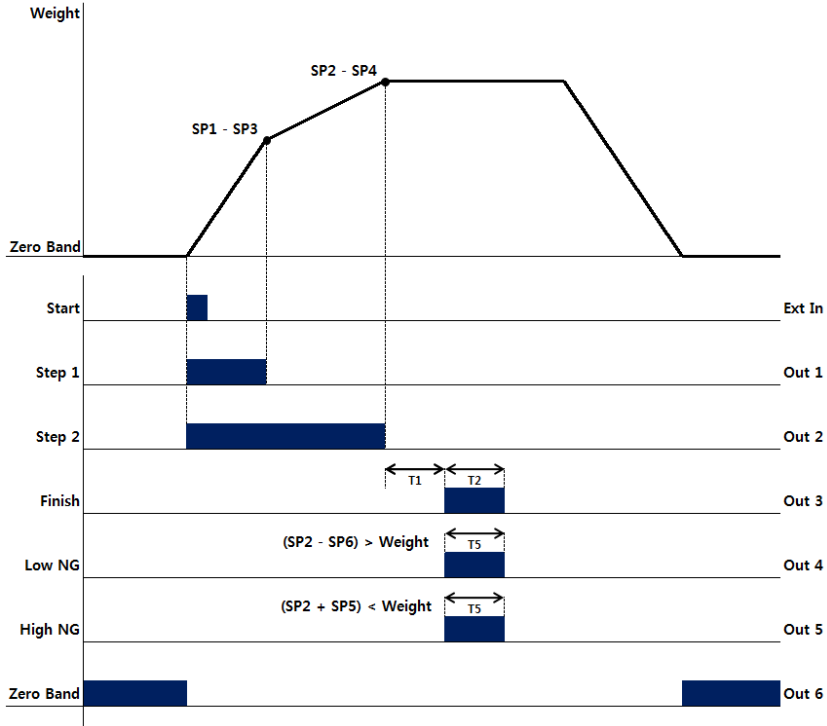

1. Set value input requirement :  $(SP2 - SP4) > (SP1 - SP3)$
2. T1 : Refer to F6.04 (Delay time of weighing Finish relay output)  
T2 : Refer to F6.05 (Operation time of weighing Finish relay output)  
T5 : Refer to F6.08 (Operation(ON) time of weighing NG relay output)
3. Relay Output

Step1 : OFF when $\{(SP1 - SP3) \leq \text{Weight}\}$
Step2 : OFF when $\{(SP2 - SP4) \leq \text{Weight}\}$
Finish : On after T1 (set time), ON after T2 (set time)
Lowest Limit NG: ON when $\{\text{Weight} < (SP2 - SP6)\}$
Upper Limit NG: ON when $\{(SP2 + SP5) < \text{Weight}\}$
Near Zero : F1-23 set value $\geq \text{Weight} \geq 0$ range output

4. Status lamp in the front panel is operated in the same manner as the RELAY output.

## <Checker mode> Relay Operation Graph upon Setting (F6.03-4)

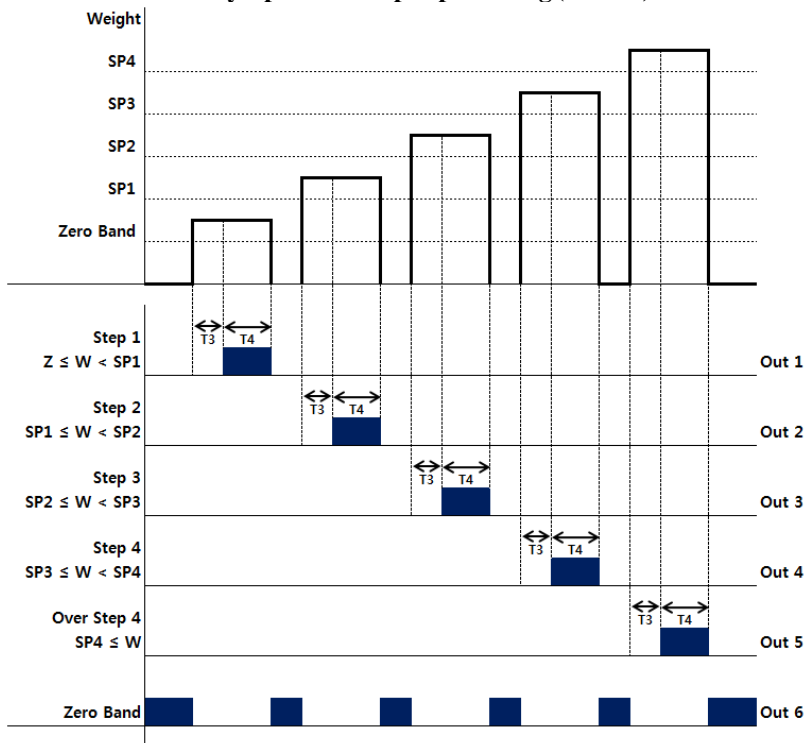

1. Required set value input :  $SP4 > SP3 > SP2 > SP1$
2.  $T3$  : Refer to F6.06 (Delay time of judgment-relay output)  
 $T4$  : Refer to F6.07 (Operation time of judgment-relay output)
3. Relay Output

Step1 : ON when Near Zero $\leq$ Weight $<$ SP1
Step2 : ON when Step1 $\leq$ Weight $<$ SP2
Step3 : ON when Step2 $\leq$ Weight $<$ SP3
Step4 : ON when Step3 $\leq$ Weight $<$ SP4
Above SP4 : ON when SP4 $\leq$ Weight
Near Zero : F1.23 set value $\geq$ Weight $\geq 0$ range output

4. Status lamp in the front panel is operated in the same manner as the RELAY output.

## <Checker mode2> Relay Operation Graph upon Setting (F6.03-5)

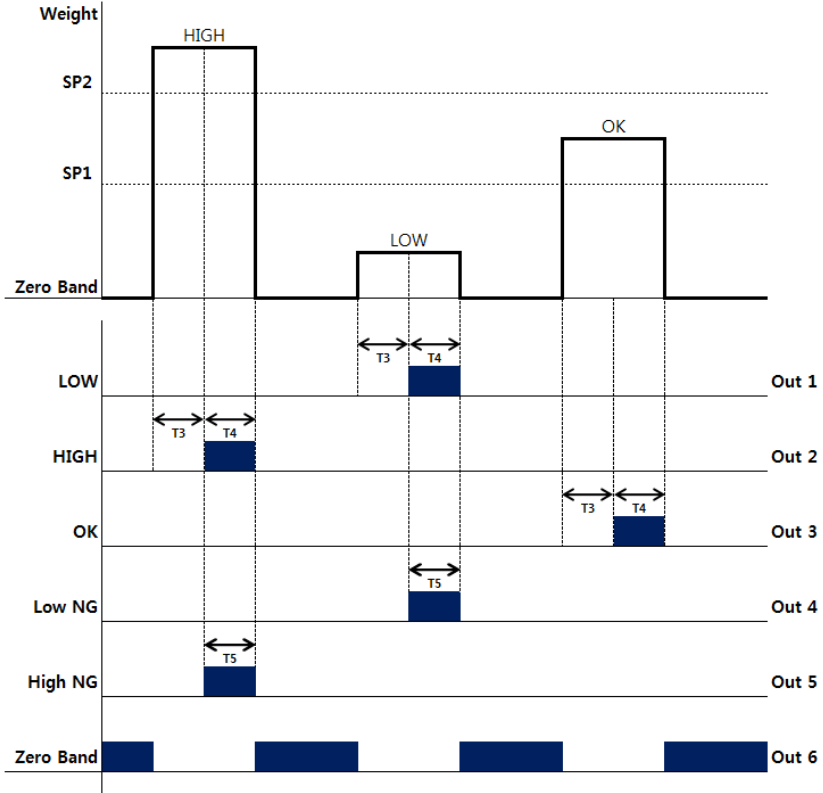

1. Required set value input :  $SP2 > SP1$
2. T3 : Refer to F6.06 (Delay time of judgment-relay output)  
T4 : Refer to F6.07 (Operation time of judgment-relay output)  
T5 : Refer to F6.08 (Operation(ON) time of weighing NG relay output)
3. Relay Output

Step1 (LOW) : ON when <b>Weight</b> < SP1
Step2 (HIGH) : ON when $SP2 < \mathbf{Weight}$
Step3 (OK) : ON when $SP1 \leq \mathbf{Weight} < SP2$
Lowest Limit NG: ON during Step1 Output, adjust Output Time on T5
Upper Limit NG: ON during Step 2 Output, adjust Output Time on T5
Near Zero : F1-23 set value $\geq \mathbf{Weight} \geq 0$ range output

4. Status lamp in the front panel is operated in the same manner as the RELAY output.

### <Checker mode3> Relay Operation Graph upon Setting (F6.03-6)

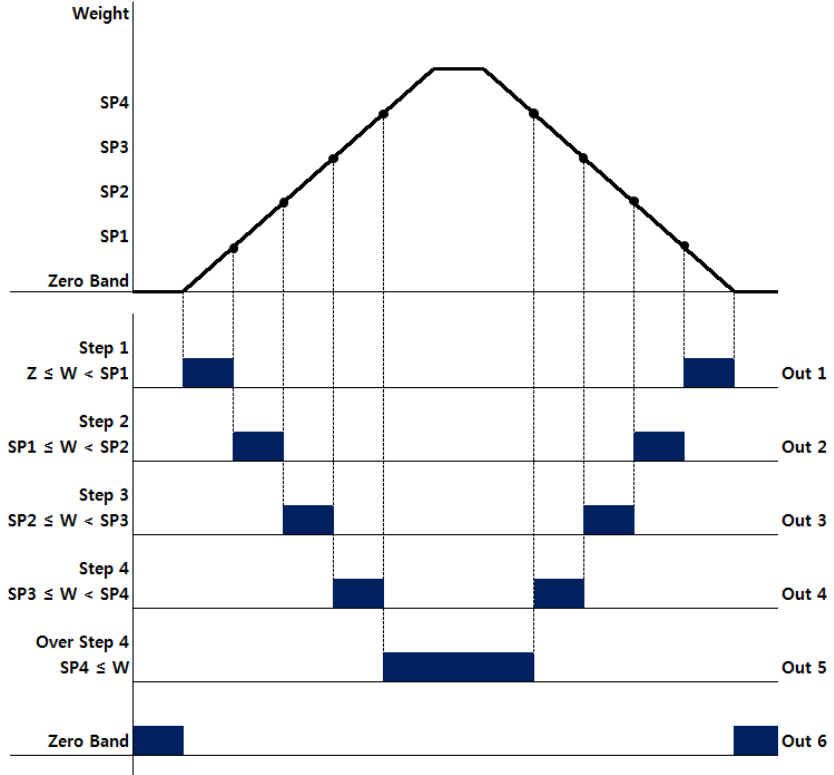

1. Required set value input :  $SP4 > SP3 > SP2 > SP1$
2. Each output relay will output if it reaches the set value or is within the range
3. Relay Output

Step1 : ON when Near Zero $\leq$ Weight $<$ SP1
Step2 : ON when Step1 $\leq$ Weight $<$ SP2
Step3 : ON when Step2 $\leq$ Weight $<$ SP3
Step4 : ON when Step3 $\leq$ Weight $<$ SP4
Above Step4 : ON when $SP4 \leq$ Weight
Near Zero : FI-23 set value $\geq$ Weight $\geq 0$ range output

4. Status lamp in the front panel is operated in the same manner as the RELAY output.

### <Checker mode4> Relay Operation Graph upon Setting (F6.03-7)

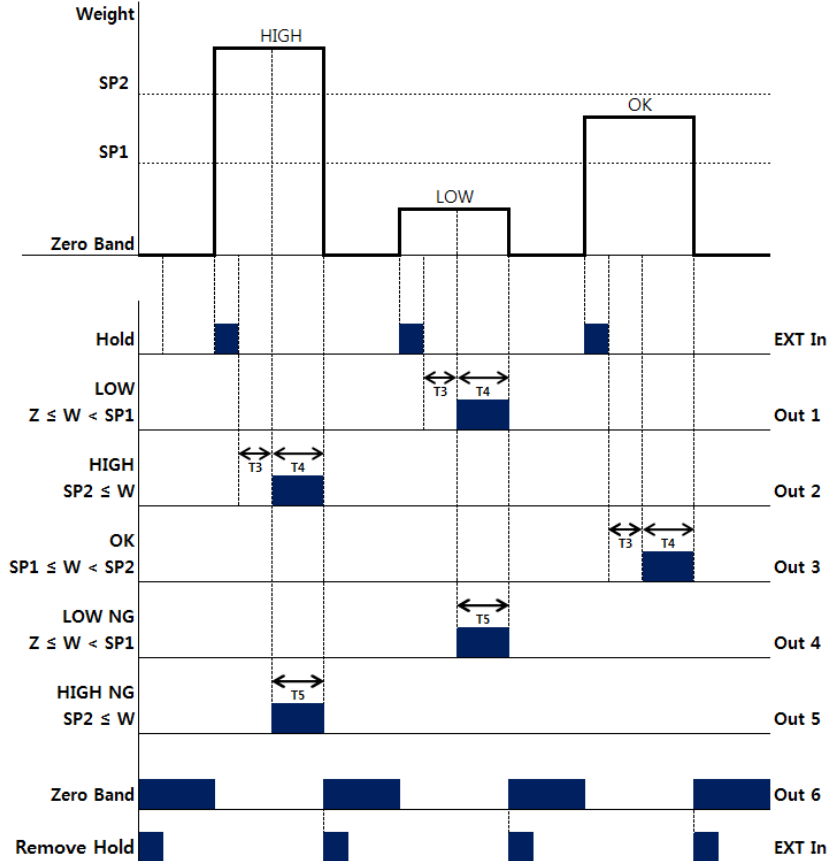

1. Required set value input :  $SP2 > SP1$
2. T3 : Refer to F6.06 (Delay time of judgment-relay output)  
T4 : Refer to F6.07 (Operation time of judgment-relay output)  
T5 : Refer to F6.08 (Operation(ON) time of weighing NG relay output)
3. This is the mode that judges via Hold Input
4. Relay Output

Step1 (LOW): During Hold Input, ON when <b>Weight</b> < SP1
Step2 (HIGH): During Hold Input, ON when $SP2 < \mathbf{Weight}$
Step3 (OK): During Hold Input, ON when $SP1 \leq \mathbf{Weight} < SP2$
Lowest Limit NG: ON during Step1 Output, adjust Output Time on T5
Upper Limit NG: ON during Step 2 Output, adjust Output Time on T5
Near Zero : F1-23 set value $\geq \mathbf{Weight} \geq 0$ range output

5. Status lamp in the front panel is operated in the same manner as the RELAY output.

## <Checker mode5> Relay Operation Graph upon Setting (F6.03-8)

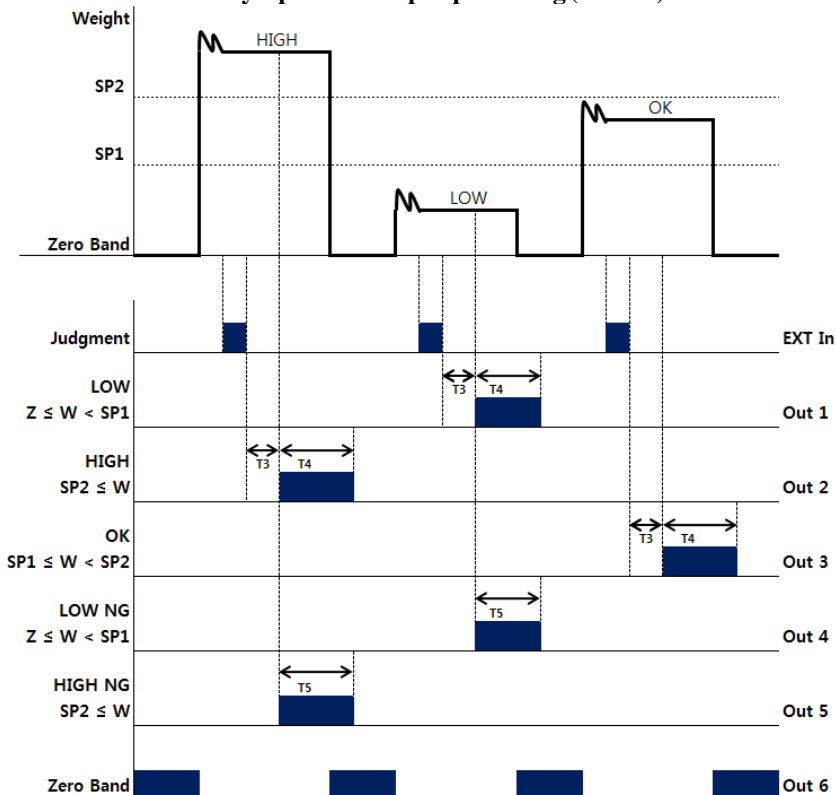

1. Required set value input:  $SP2 > SP1$
2. T3: Refer to F6.06 (Delay time of judgment-relay output)  
T4: Refer to F6.07 (Operation time of judgment-relay output)  
T5: Refer to F6.08 (Operation (ON) time of weighing NG relay output)
3. This is the mode that judges via Judgment Input
4. Relay Output

Step1 (LOW): During Judgment Input, ON when <b>Weight</b> < SP1
Step2 (HIGH): During Judgment Input, ON when <b>SP2</b> < <b>Weight</b>
Step3 (OK): During Judgment Input, ON when <b>SP1</b> ≤ <b>Weight</b> < <b>SP2</b>
Lowest Limit NG: ON during Step1 Output, adjust Output Time on T5
Upper Limit NG: ON during Step 2 Output, adjust Output Time on T5
Near Zero : F1-23 set value ≥ <b>Weight</b> ≥ 0 range output

5. Status lamp in the front panel is operated in the same manner as the RELAY output.

## <Auto Tare Packer Mode> Relay Operation Graph upon Setting (F6.03-9)

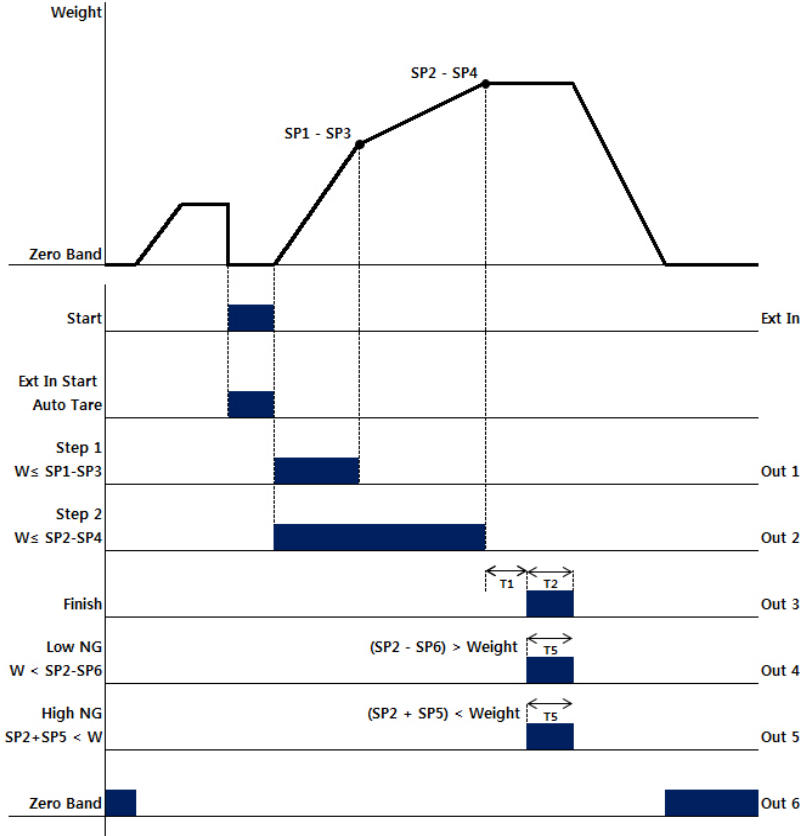

1. Set value input requirement :  $(SP2 - SP4) > (SP1 - SP3)$
2. T1: Refer to F6.04 (Delay time of weighing Finish relay output)  
T2: Refer to F6.05 (Operation time of weighing Finish relay output)  
T5: Refer to F6.08 (Operation(ON) time of weighing NG relay output)
3. Relay Output

Step1 : ON when $\{(SP1 - SP3) \leq \text{Weight}\}$
Step2 : ON when $\{(SP2 - SP4) \leq \text{Weight}\}$
Finish : On after T1 (set time), ON after T2 (set time)
Lowest Limit NG : ON when $\{\text{Weight} < (SP2 - SP6)\}$
Upper Limit NG : ON when $\{(SP2 + SP5) < \text{Weight}\}$
Near Zero : F1-23 set value $\geq \text{Weight} \geq 0$ range output

4. Status lamp in the front panel is operated in the same manner as the RELAY output.

## <Auto Tare Auto Packer Mode> Relay Operation Graph upon Setting (F6.03-10)

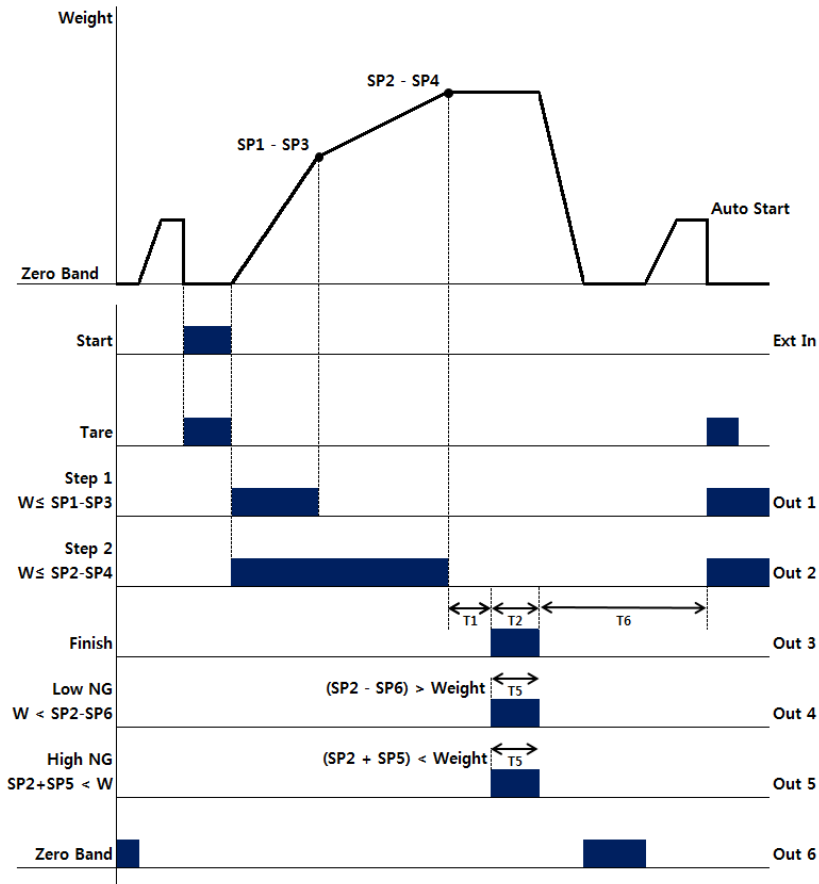

1. Set value input requirement :  $(SP2 - SP4) > (SP1 - SP3)$
2.  $T1$  : Refer F6.04 (Delay time of weighing Finish relay output)  
 $T2$ : Refer to F6.05 (Operation time of weighing Finish relay output)  
 $T5$ : Refer to F6.08 (Operation(ON) time of weighing NG relay output)  
 $T6$ : Refer to F6.11 (Restart delay time after finish output)
3. Relay Output

Step1 : ON when $\{(SP1 - SP3) \leq Weight\}$
Step2 : ON when $\{(SP2 - SP4) \leq Weight\}$
Finish : On after $T1$ (set time), ON after $T2$ (set time)
Lowest Limit NG : ON when $\{Weight < (SP2 - SP6)\}$
Upper Limit NG : ON when $\{(SP2 + SP5) < Weight\}$
Near Zero : F1-23 set value $\geq Weight \geq 0$ range output

4. Status lamp in the front panel is operated in the same manner as the RELAY output.

<Auto Zero Auto Packer Mode> Relay Operation Graph upon Setting (F6.03-11)

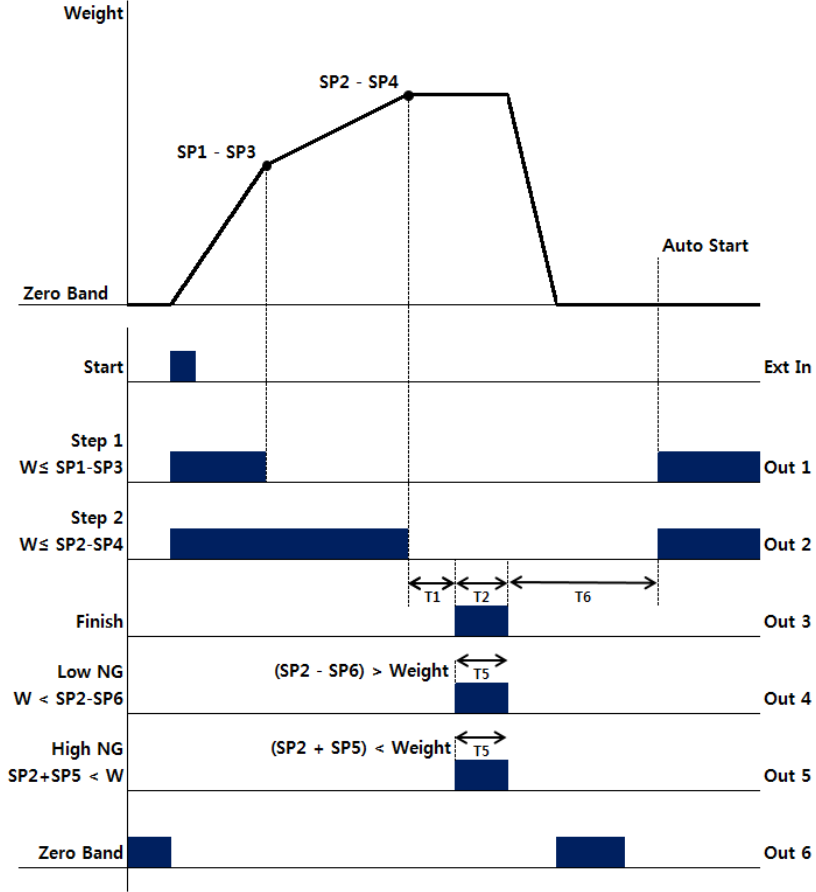

1. Set value input requirement :  $(SP2 - SP4) > (SP1 - SP3)$
2. T1: Refer to F6.04 (Delay time of weighing Finish relay output)  
T2: Refer to F6.05 (Operation time of weighing Finish relay output)  
T5: Refer to F6.08 (Operation(ON) time of weighing NG relay output)  
T6: Refer to F6.11 (Restart delay time after finish output)
3. Relay Output

Step1 : ON when $\{(SP1 - SP3) \leq \text{Weight}\}$
Step2 : ON when $\{(SP2 - SP4) \leq \text{Weight}\}$
Finish : On after T1 (set time), ON after T2 (set time)
Lowest Limit NG : ON when $\{\text{Weight} < (SP2 - SP6)\}$
Upper Limit NG : ON when $\{(SP2 + SP5) < \text{Weight}\}$
Near Zero : F1-23 set value $\geq \text{Weight} \geq 0$ range output

4. Status lamp in the front panel is operated in the same manner as the RELAY output.

## CI-407 Relay Output Setting

### Menu-F6.03: Relay Mode

Function	Relay Mode	
Set Range (0~9)	Display	Description
	6-03. 0	Limit Mode (Fall and Weighing Decision)
	6-03. 1	Packer Mode
	6-03. 2	Loss in weight (3 Step Discharging Mode)
	6-03. 3	1 Step Feeding, 2 Step Discharging Mode_1
	6-03. 4	1 Step Feeding, 2 Step Discharging Mode_2
	6-03. 5	2 Step Feeding, 1 Step Discharging Mode
	6-03. 6	3 Step Discharging Mode_1
	6-03. 7	3 Step Discharging Mode_2
	6-03. 8	2 Step Feeding, 2 Step Discharging Mode_1
6-03. 9	2 Step Feeding, 2 Step Discharging Mode_2	

### Set Point Mapping Information per Mode

Relay Mode	SP 1	SP 2	SP 3	SP 4	SP 5	SP 6	SP 7	SP 8	SP 9
0_Limit Mode	Step 1	Step 2	Fall		Upper Limit NG	Lower Limit NG	Setting Value		
1_Packer Mode	Step 1	Step 2	Fall		Upper Limit NG	Lower Limit NG	Setting Value		
2_Loss in weight	Step 1	Step 2	Fall		Upper Limit NG	Lower Limit NG	Setting Value		
3_1 Step Feeding, 2 Step Discharging Mode_1	Step 1	Step 2	Fall		Upper Limit NG	Lower Limit NG	Setting Value		
4_1 Step Feeding, 2 Step Discharging Mode_2	Step 1	Step 2	Fall		Upper Limit NG	Lower Limit NG	Setting Value		
5_2 Step Feeding, 1 Step Discharging Mode	Step 1	Step 2	Fall		Upper Limit NG	Lower Limit NG	Setting Value		
6_3 Step Discharging Mode_1	Step 1	Step 2	Step 3		Upper Limit NG	Lower Limit NG	Setting Value	Fall	
7_3 Step Discharging Mode_2	Step 1	Step 2	Step 3		Upper Limit NG	Lower Limit NG	Setting Value	Fall	
8_2 Step Feeding, 2 Step Discharging Mode_1	Step 1	Step 2	Step 3	Step 4	Upper Limit NG	Lower Limit NG	Setting Value	Fall	
9_2 Step Feeding, 2 Step Discharging Mode_2	Step 1	Step 2	Step 3	Step 4	Upper Limit NG	Lower Limit NG	Setting Value	Supply Fall	Discharge Fall

Note 1. See the above Table for Set Point Values applied for each weighing per mode

### Weighing Output Information per Mode

Relay Mode	OUT 1	OUT 2	OUT 3	OUT 4	OUT 5	OUT 6
0_Limit Mode	Step 1	Step 2	Step 3	Lower Limit NG	Upper Limit NG	Zero
1_Packer Mode	Step 1	Step 2	Step 3	Finish	Error	Zero
2_Loss in weight	Step 1	Step 2	Step 3	Lower Limit NG	Upper Limit NG	Zero
3_1 Step Feeding, 2 Step Discharging Mode_1	Step 1	Step 2	Step 3	Lower Limit NG	Upper Limit NG	Zero
4_1 Step Feeding, 2 Step Discharging Mode_2	Step 1	Step 2	Step 3	Finish	Error	Zero
5_2 Step Feeding, 1 Step Discharging Mode	Step 1	Step 2	Step 3	Finish	Error	Zero
6_3 Step Discharging Mode_1	Step 1	Step 2	Step 3	Finish	Error	Zero
7_3 Step Discharging Mode_2	Step 1	Step 2	Step 3	Finish	Error	Zero
8_2 Step Feeding, 2 Step Discharging Mode_1	Step 1	Step 2	Step 3	Step 4	Finish	Zero
9_2 Step Feeding, 2 Step Discharging Mode_2	Step 1	Step 2	Step 3	Step 4	Finish	Zero

### Menu-F6.04: F\_Relay Delay Start Time

Function	Set Start Delay Time for completed Relay	
Set Range (0~99)	Display Part	Meaning
	6-04. 10 <b>Initial Value:</b> 10 x 0.1 Sec	Delayed by 00 x 0.1 Sec

### Menu-F6.05: F\_Relay Operating Duration

Function	Set Operating Duration Time for completed Relay	
Set Range (0~99)	Display Part	Meaning
	6-05. 10 <b>Initial Value:</b> 10 x 0.1 Sec	Lasts for 00 x 0.1 Sec

### Menu-F6.06: C\_Relay Delay Start Time

Function	Set Start Delay Time for Decision Relay	
Set Range (0~99)	Display Part	Meaning
	6-06. 0 <b>Initial Value:</b> 0 x 0.1 Sec	Delayed by 00 x 0.1 Sec

### Menu-F6.07: C\_Relay Operating Duration

Function	Set Operating Duration Time for Decision Relay	
Set Range (0~99)	Display Part	Meaning
	6-07. 20 <b>Initial Value:</b> 20 x 0.1 Sec	Lasts for 00 x 0.1 Sec

### Menu-F6.08: NG\_Relay Delay Start Time

Function	Set Start Delay Time for Decision Relay	
Set Range (0~99)	Display Part	Meaning
	6-08. 0 <b>Initial Value:</b> 0 x 0.1 Sec	Lasts for 00 x 0.1 Sec

### Menu-F6.09: NG\_Relay Operating Duration

Function	Set Operating Time for Weighing NG Relay	
Set Range (0~99)	Display Part	Meaning
	6-09. 20 <b>Initial Value:</b> 20 x 0.1 Sec	Lasts for 00 x 0.1 Sec

### Menu-F6.10: Relay Operating Range

Function	Relay Operating Range	
	Display Part	Meaning
Set Range (0~2)	<b>6-10. 0</b>	<b>Relay is operating in only +(weight) range</b>
	6-9. 1	Relay is operating in only -(weight) range
	6-9. 2	Relay is operating in +,-(weight) range

### Menu-F6.11: Delay Time of Start

Function	Set Delay time of start	
	Display Part	Meaning
Set Range (0~99)	6-10. 10	Delayed by 00 x 0.1 Sec
	<b>Initial Value: 10 x 0.1 Sec</b>	

### Menu-F6.13: Start Condition\_Pack\_M1

Function	Start condition of Packer mode 1	
	Display Part	Meaning
Set Range (0, 1)	<b>6-13. 0</b>	<b>Relay start operating is only zero range</b>
	6-13. 1	Relay start operating is always

## CI-407 Relay Timing graph

### <Limit mode> Relay Operation Graph upon Setting (F6.03- 0)

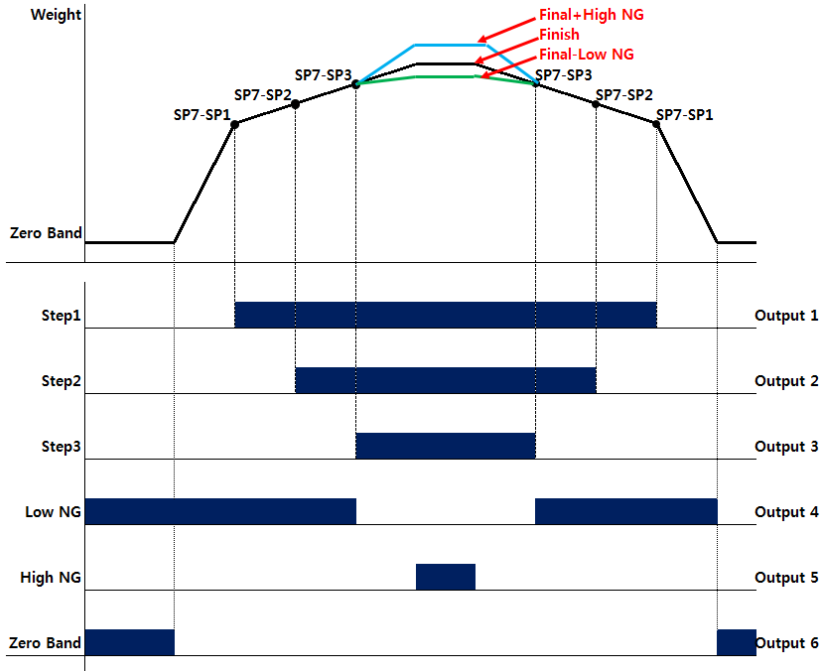

1. Required set value input : Final(SP7) > Step 1(SP1) > Step 2(SP2) > Fall(SP3)
2. **SP1**: Step 1, **SP2**: Step 2, **SP3**: Fall, **SP5**: Upper Limit NG **SP6**: Lowest Limit NG **SP7**: Final
2. Near zero output is according to the specified range in F1-23
3. Relay Output

Step 1 : ON when $\{(SP7 - SP1) \leq \text{Weight}\}$
Step 2 : ON when $\{(SP7 - SP2) \leq \text{Weight}\}$
Step 3 : ON when $\{(SP7 - \text{Fall}) \leq \text{Weight}\}$
Lowest Limit NG : ON when $\{\text{Weight} < (SP7 - SP6)\}$
Upper Limit NG : ON when $\{(SP7 + SP5) < \text{Weight}\}$
Near Zero : F1-23 set value $\geq \text{Weight} \geq 0$ range output

4. Status lamp in the front panel is operated in the same manner as the RELAY output.

## <Packer mode> Relay Operation Graph upon Setting (F6.03-1)

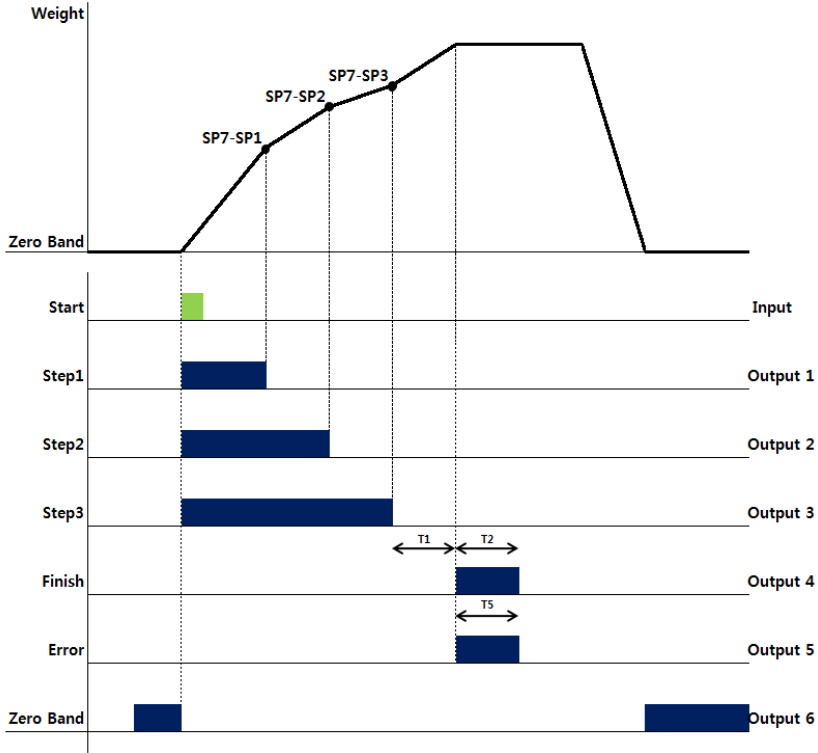

1. Required set value input : Final (SP7) > Step 1(SP1) > Step 2(SP2) > Fall (SP3)
2. **SP1**: Step1, **SP2**: Step2, **SP3**: Fall, **SP5**: Upper Limit NG, **SP6**: Lowest Limit NG, **SP7**: Final
3. Near zero output is according to the specified range in F1-23
4. T1 : Refer to F6.04 (Delay time of weighing Finish relay output)  
T2 : Refer to F6.05 (Operation time of weighing Finish relay output)  
T5 : Refer to F6.09 (Operation(ON) time of weighing NG relay output)
5. Relay Output

Step 1 : OFF when $(SP7 - SP1 \leq \text{Weight})$
Step 2 : OFF when $(SP7 - SP2 \leq \text{Weight})$
Step 3 : OFF when $(SP7 - SP3 \leq \text{Weight})$
Finish : On after T1 (set time), ON during T2 (set time)
Error : When weighing is completed $\{\text{Weight} < (SP7 - SP6)\}$ or $\{(SP7 + SP5) < \text{Weight}\}$ , ON for the during of T5 (set time)
Near Zero : F1-23 set value $\geq \text{Weight} \geq 0$ range output

6. Status lamp in the front panel is operated in the same manner as the RELAY output.

## <Loss in weight\_3 Step Discharging Mode >

### Relay Operation Graph upon Setting (F6.03-2)

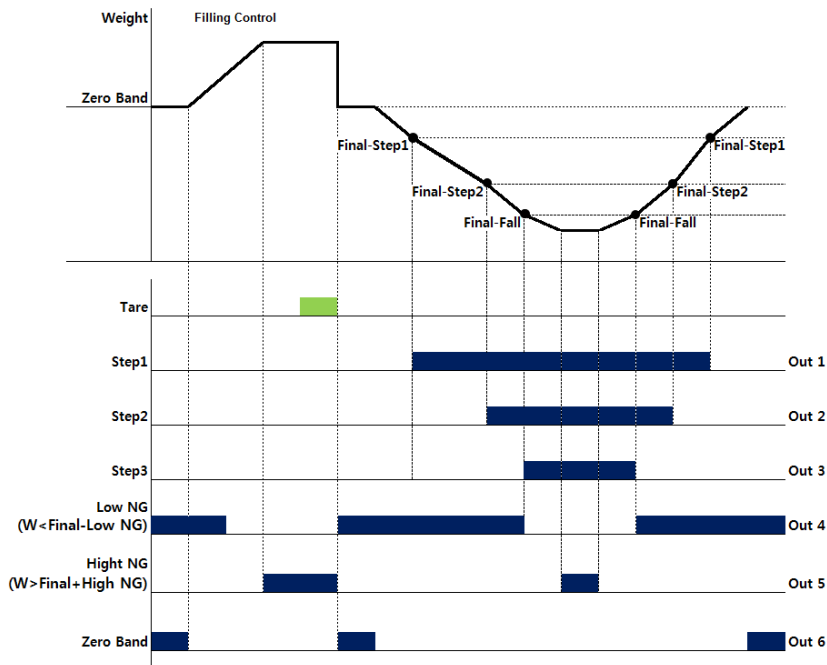

1. Required set value input : Final (SP7) > Step 1(SP1) > Step 2(SP2) > Fall (SP3)
2. **SP1**: Step1, **SP2**: Step2, **SP3**: Fall, **SP5**: Upper Limit NG, **SP6**: Lowest Limit NG, **SP7**: Final
3. Near zero output is according to the specified range in F1-23
4. Relay Output

Step 1 : ON OFF when $(SP7 - SP1 \leq \text{Discharge Weight})$
Step 2 : ON OFF when $(SP7 - SP2 \leq \text{Discharge Weight})$
Step 3 : ON OFF when $(SP7 - SP3 \leq \text{Discharge Weight})$
Lowest Limit NG : ON when $\{ \text{Discharge Weight} < (SP7 - SP6) \}$
Upper Limit NG : ON when $\{ (SP7 + SP5) < \text{Discharge Weight} \}$
Near Zero : F1-23 set value $\geq \text{Weight} \geq 0$ range output

5. Status lamp in the front panel is operated in the same manner as the RELAY output.

## <1 Step Feeding, 2 Step Discharging Mode\_1> Relay Operation Graph upon Setting (F6.03-3)

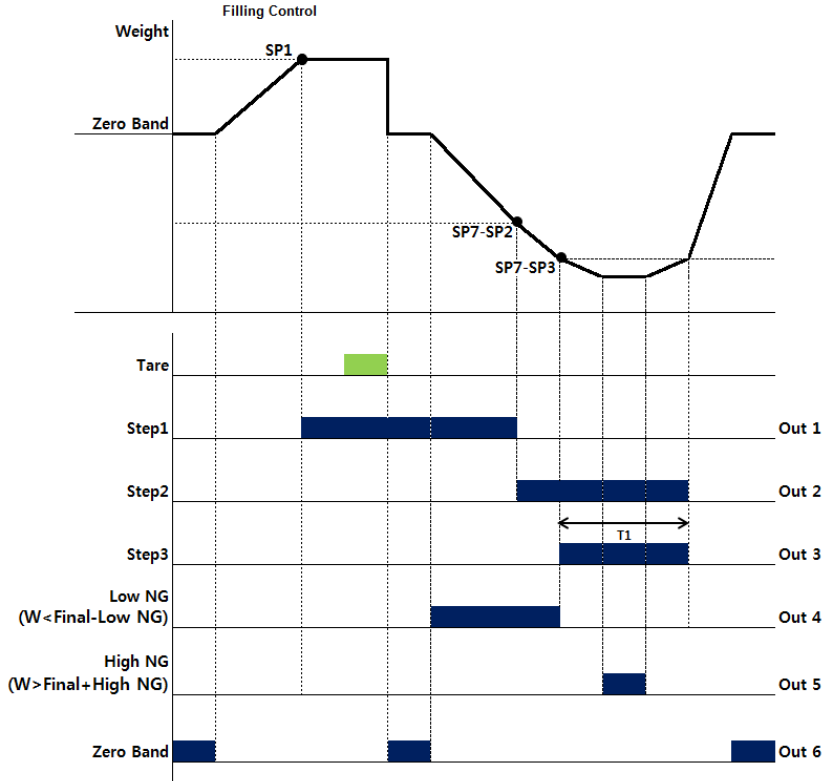

1. Required set value input : Step 1(SP1) > Final(SP7) > Step 2(SP2) > Fall(SP3)
2. **SP1:** Step1, **SP2:** Step2, **SP3:** Fall, **SP5:** Upper Limit NG **SP6:** Lowest Limit NG **SP7:** Final
3. Near zero output is according to the specified range in F1-23
4. T1 : Refer to F6.04 (Delay time of weighing Finish relay output)
5. Relay Output

Step 1 : ON when ( SP1 ≤ Weight )
Step 2 : ON when { (SP7 - SP2) ≤ Discharge Weight }, OFF after T1 (set time),
Step 3 : ON when { (SP7 - SP3) ≤ Discharge Weight }, OFF after T1 (set time),
Lowest Limit NG : ON when { Discharge Weight < (SP7 - SP6) }
Upper Limit NG : ON when { (SP7 + SP5) < Discharge Weight }
Near Zero : F1-23 set value ≥ Weight ≥ 0 range output

6. Status lamp in the front panel is operated in the same manner as the RELAY output.

## <1 Step Feeding, 2 Step Discharging Mode\_2>

### Relay Operation Graph upon Setting (F6.03-4)

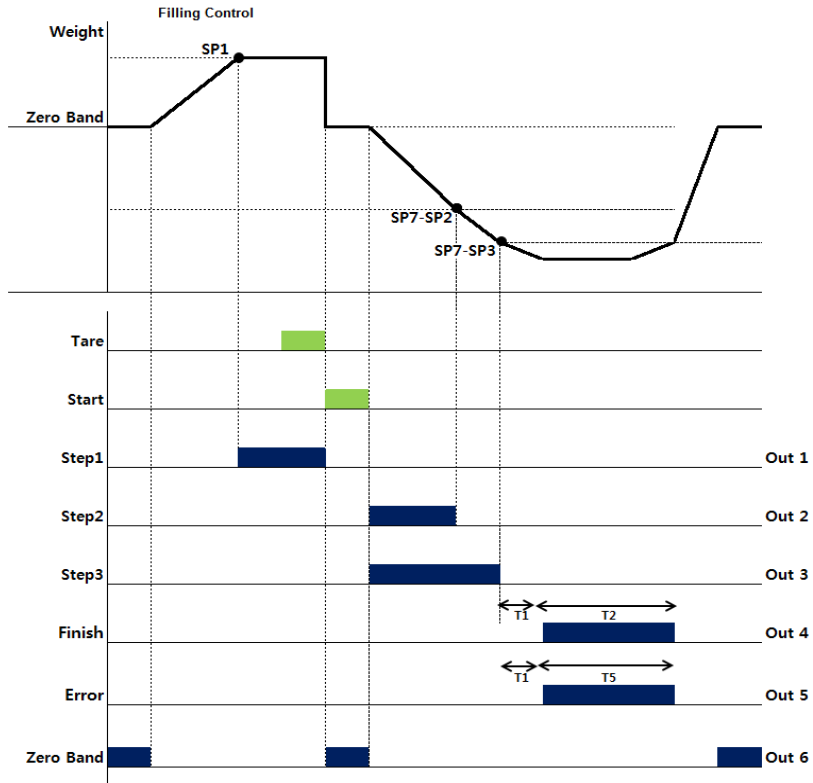

1. Required set value input : Step 1(SP1) > Final(SP7) > Step 2(SP2) > Fall(SP3)
2. **SP1**: Step1, **SP2**: Step2, **SP3**: Fall, **SP5**: Upper Limit NG **SP6**: Lowest Limit NG **SP7**: Final
3. Near zero output is according to the specified range in F1-23
4. T1 : Refer to F6.04 (Delay time of weighing Finish relay output)  
T2 : Refer to F6.05 (Operation time of weighing Finish relay output)  
T5 : Refer to F6.09 (Operation(ON) time of weighing NG relay output)
5. Relay Output

Step 1 : ON when ( $SP1 \leq \text{Weight}$ ), OFF When start input
Step 2 : ON When start input , OFF when $\{ (SP7 - SP2) \leq \text{Discharge Weight} \}$ ,
Step 3 : ON When start input , OFF when $\{ (SP7 - SP3) \leq \text{Discharge Weight} \}$ ,
Finish : On after T1 (set time), ON during T2 (set time)
Error : When weighing is completed $\{ \text{Discharge Weight} < (SP7 - SP6) \}$ or $\{ (SP7 + SP5) < \text{Discharge Weight} \}$ , ON for the during of T5 (set time)
Near Zero : F1-23 set value $\geq \text{Weight} \geq 0$ range output

6. Status lamp in the front panel is operated in the same manner as the RELAY output.

**<2 Step Feeding, 1 Step Discharging Mode>  
Relay Operation Graph upon Setting (F6.03-5)**

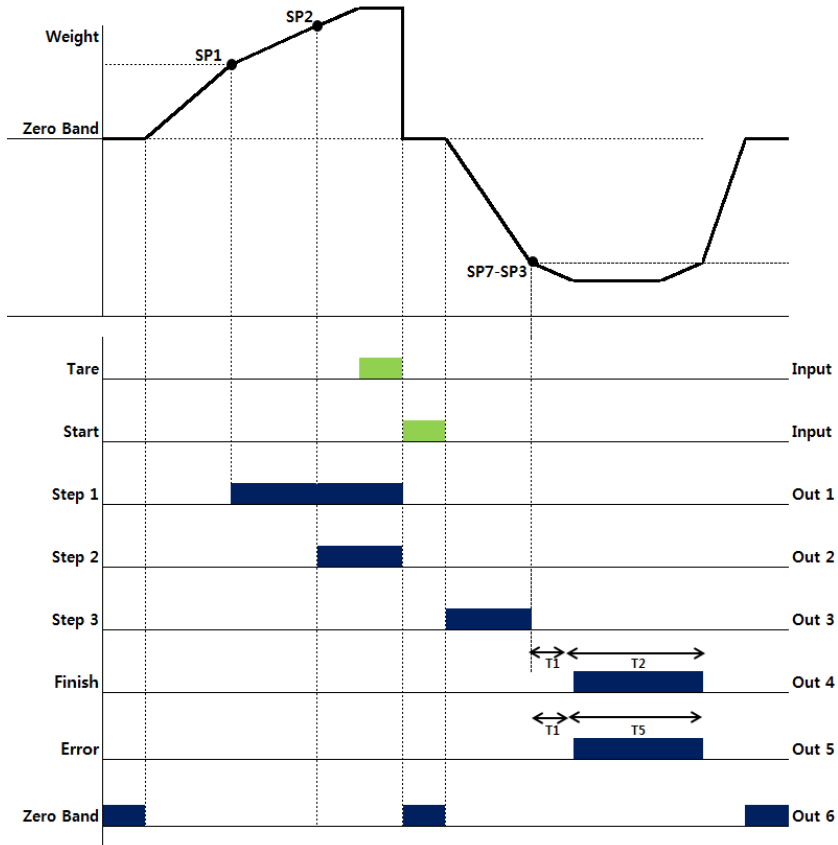

1. Required set value input : Step 2(SP2) > Step 1(SP1) > Final (SP7) > Fall (SP3)
2. **SP1**: Step1, **SP2**: Step2, **SP3**: Fall, **SP5**: Upper Limit NG, **SP6**: Lowest Limit NG, **SP7**: Final
3. Near zero output is according to the specified range in F1-23
4. T1 : Refer to F6.04 (Delay time of weighing Finish relay output)  
T2 : Refer to F6.05 (Operation time of weighing Finish relay output)  
T5 : Refer to F6.09 (Operation(ON) time of weighing NG relay output)
5. Relay Output

Step 1 : ON when ( SP1 ≤ Weight), OFF When start input
Step 2 : ON when ( SP2 ≤ Weight), OFF When start input
Step 3 : ON When start input , OFF when { (SP7 - SP3) ≤ Discharge Weight},
Finish : On after T1 (set time), ON during T2 (set time)
Error : When weighing is completed { Discharge Weight < (SP7 - SP6) } or { (SP7 + SP5) < Discharge Weight}, ON for the during of T5 (set time)
Near Zero : FI-23 set value ≥ Weight ≥ 0 range output

6. Status lamp in the front panel is operated in the same manner as the RELAY output.

### <3 Step Discharging Mode\_1> Relay Operation Graph upon Setting (F6.03-6)

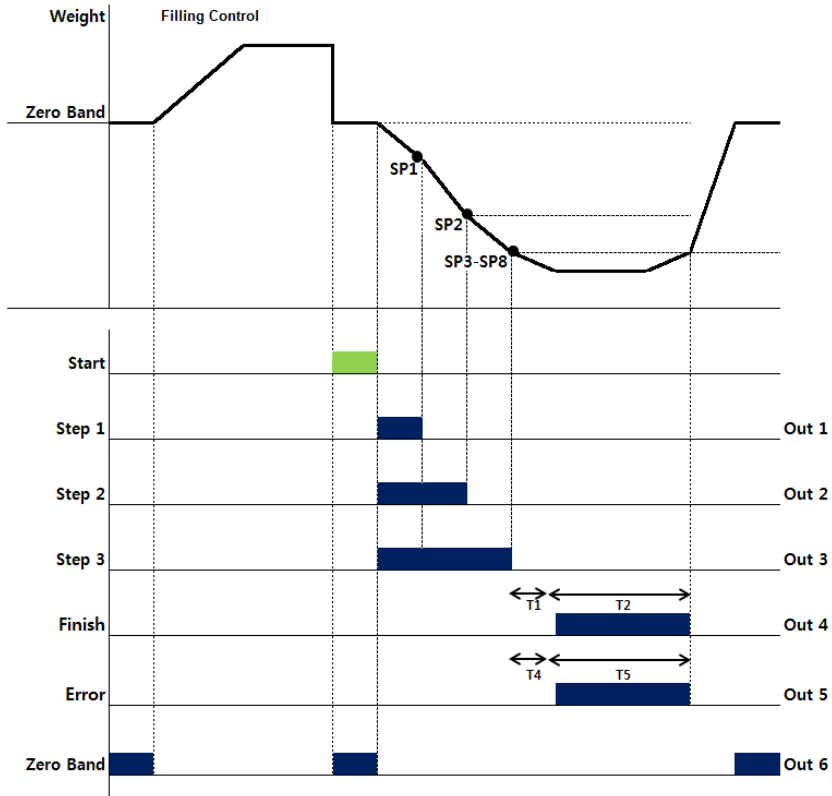

1. Required set value input : Step 3(SP3) – Fall(SP8) > Step 2(SP2) > Step 1(SP1)
2. **SP1**:Step1, **SP2**:Step2, **SP3**: Step3, **SP5**: Upper Limit NG **SP6**: Lowest Limit NG **SP7**: Final, **SP8**:Fall
3. Near zero output is according to the specified range in F1-23
4. T1 : Refer to F6.04 (Delay time of weighing Finish relay output)  
T2 : Refer to F6.05 (Operation time of weighing Finish relay output)  
T4 : Refer to F6.08 (Delay time of weighing NG relay output)  
T5 : Refer to F6.09 (Operation(ON) time of weighing NG relay output)
5. Relay Output

Step 1 : ON When start input, OFF when ( SP1 ≤ Discharge Weight )
Step 2 : ON When start input, OFF when ( SP2 ≤ Discharge Weight )
Step 3 : ON When start input, OFF when { (SP3 – SP8) ≤ Discharge Weight }
Finish : On after T1 (set time), ON during T2 (set time)
Error : When weighing is completed { Discharge Weight < (SP7 – SP6) } or { (SP7 + SP5) < Discharge Weight }, ON for the during of T5 (set time)
Near Zero : F1-23 set value ≥ Weight ≥ 0 range output

6. Status lamp in the front panel is operated in the same manner as the RELAY output.

### <3 Step Discharging Mode\_2> Relay Operation Graph upon Setting (F6.03-7)

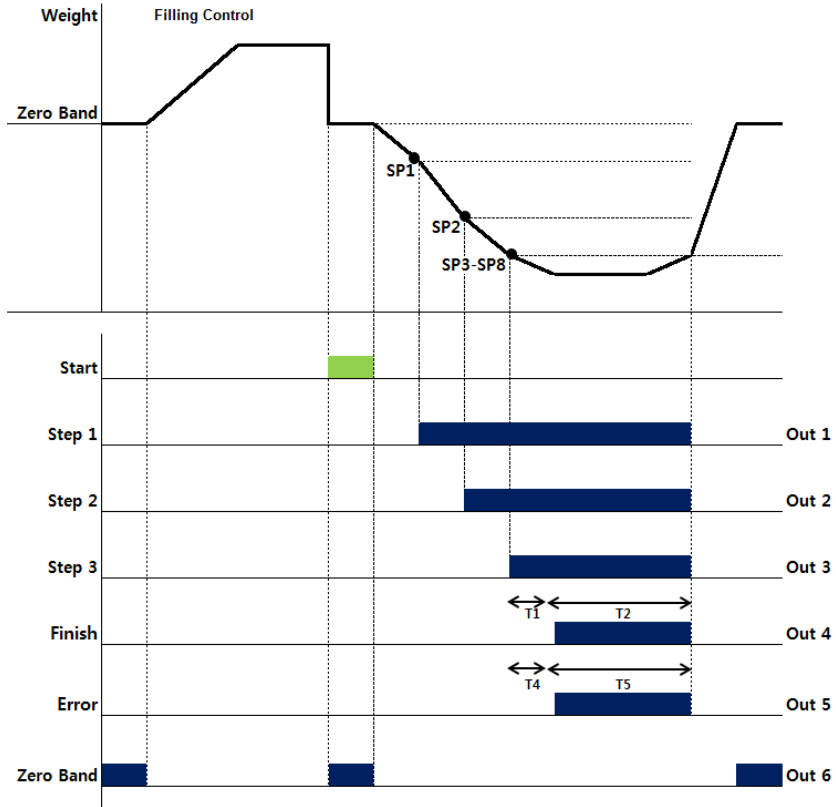

1. Required set value input : Step 3(SP3) – Fall (SP8) > Step 2(SP2) > Step 1(SP1)
2. SP1: Step1, SP2: Step2, SP3: Step3, SP5: Upper Limit NG SP6: Lowest Limit NG SP7: Final, SP8: Fall
3. Near zero output is according to the specified range in F1-23
4. T1 : Refer to F6.04 (Delay time of weighing Finish relay output)  
 T2 : Refer to F6.05 (Operation time of weighing Finish relay output)  
 T4 : Refer to F6.08 (Delay time of weighing NG relay output)  
 T5 : Refer to F6.09 (Operation(ON) time of weighing NG relay output)
5. Relay Output

Step 1 : ON when ( SP1 ≤ Discharge Weight )
Step 2 : ON when ( SP2 ≤ Discharge Weight )
Step 3 : ON when { (SP3 – SP8) ≤ Discharge Weight }
Finish : On after T1 (set time), ON during T2 (set time)
Error : When weighing is completed { Discharge Weight < (SP7 – SP6) } or { (SP7 + SP5) < Discharge Weight }, ON for the during of T5 (set time)
Near Zero : F1-23 set value ≥ Weight ≥ 0 range output

6. Status lamp in the front panel is operated in the same manner as the RELAY output.

<2 Step Feeding, 2 Step Discharging Mode\_1>  
 Relay Operation Graph upon Setting (F6.03-8)

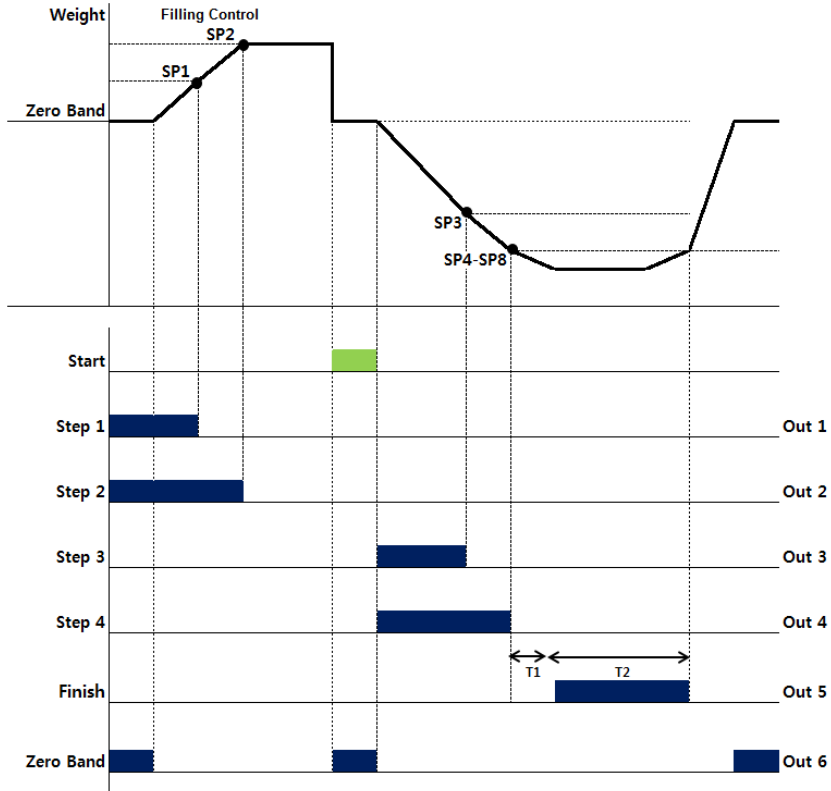

1. Required set value input : Step 2(SP2) > Step 1(SP1), Step 4(SP4) – Fall(SP8) > Step 3(SP3)
2. **SP1**: Step1, **SP2**: Step2, **SP3**: Step3, **SP4**: Step4, **SP5**: Upper Limit NG  
**SP6**: Lowest Limit NG, **SP7**: Final, **SP8**: Fall
3. Near zero output is according to the specified range in F1-23
4. T1 : Refer to F6.04 (Delay time of weighing Finish relay output)  
 T2 : Refer to F6.05 (Operation time of weighing Finish relay output)
5. Relay Output

Step 1 : OFF when ( SP1 ≤ Weight)
Step 2 : OFF when ( SP2 ≤ Weight)
Step 3 : ON When start input, OFF when (SP3 ≤ Discharge Weight)
Step 4 : ON When start input, OFF when ( (SP4 – SP8) ≤ Discharge Weight)
Finish : On after T1 (set time), ON during T2 (set time)
Near Zero : F1-23 set value ≥ Weight ≥ 0 range output

6. Status lamp in the front panel is operated in the same manner as the RELAY output.

**◁ 2 Step Feeding, 2 Step Discharging Mode ▷**  
**Relay Operation Graph upon Setting (F6.03-9)**

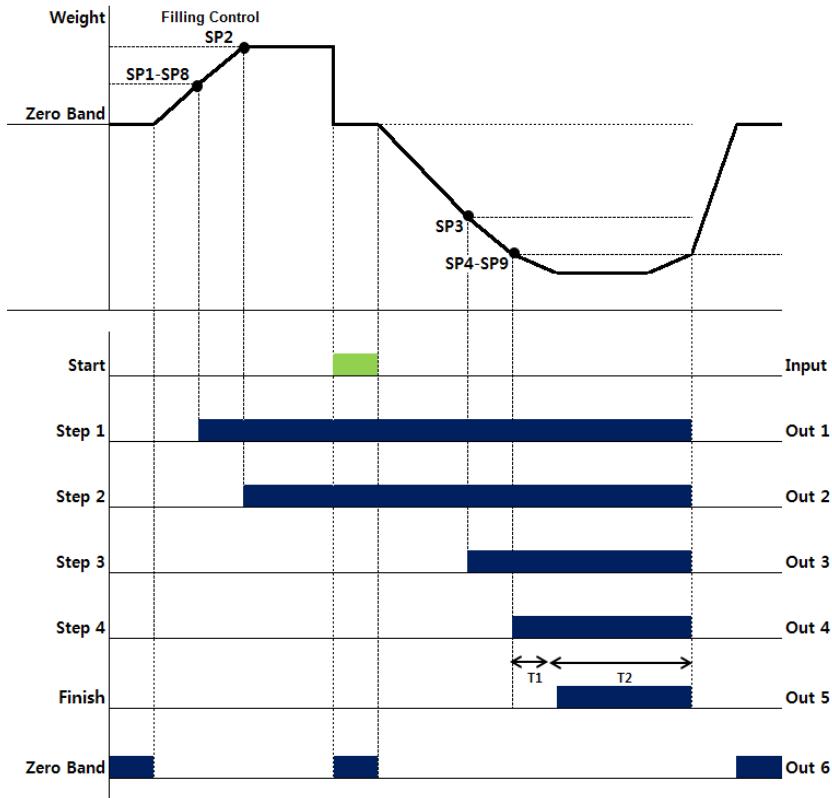

1. Required set value input : Step 2(SP2) – Supply Fall(SP8) > Step 1(SP1),  
 Step 4(SP4) – Discharge Fall(SP9) > Step 3(SP3)
2. **SP1**: Step 1, **SP2**: Step 2, **SP3**: Step 3, **SP4**: Step 4, **SP5**: Upper Limit NG  
**SP6**: Lowest Limit NG **SP7**: Final, **SP8**: Supply Fall, **SP9**: Discharge Fall
3. Near zero output is according to the specified range in F1-23
4. T1 : Refer to F6.04 (Delay time of weighing Finish relay output)  
 T2 : Refer to F6.05 (Operation time of weighing Finish relay output)
5. Relay Output

Step 1 : ON when ( SP1 – SP8 ≤ Weight )
Step 2 : ON when ( SP2 ≤ Weight )
Step 3 : ON when ( SP3 ≤ Discharge Weight )
Step 4 : ON when ( SP4 – SP9 ≤ Discharge Weight )
Finish : On after T1 (set time), ON during T2 (set time)
Near Zero : F1-23 set value ≥ Weight ≥ 0 range output

6. Status lamp in the front panel is operated in the same manner as the RELAY output.

## Standard) External Input Connector Pin Information

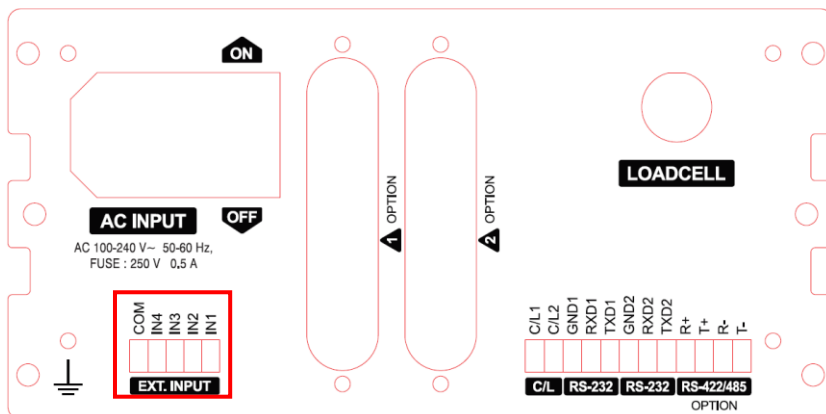

### Ext In Pin Map

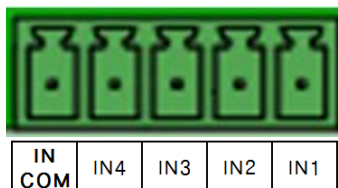

Pin No	Signal
1	Ext In 1
2	Ext In 2
3	Ext In 3
4	Ext In 4
5	In Common(GND)

## 8. OPTION

### 8-1 Relay In4 / Out6

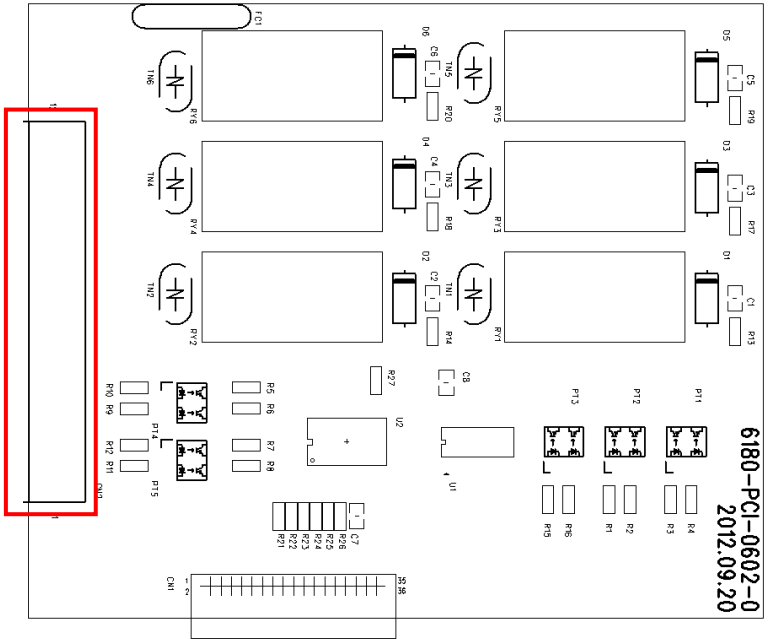

#### ■ General

- 4 External Input
- 6 External Output(Relay out)
- Operating temperature range : -10℃ ~40℃
- Connector : Terminal Block - 12 Pin

Item		Specification
Contact Data	Resistance (Initial)	Max. 100 mΩ at 6V <sub>DC</sub> , 1A
	Contact rating	1A, 24 V <sub>DC</sub> /0.5A, 120V <sub>AC</sub>
	Max Switching Voltage	60 V <sub>DC</sub> / 120 V <sub>AC</sub>
Life	Mechanical	Min 20 X 10 <sup>6</sup> Operations
	Electronical (at contact rating)	Min 200X10 <sup>3</sup> Operations (0.5A, 120 V <sub>AC</sub> ) Min 500X10 <sup>3</sup> Operations (1A, 24 V <sub>DC</sub> )

## ■ Connection of Input & Output

### Input (A Contact)

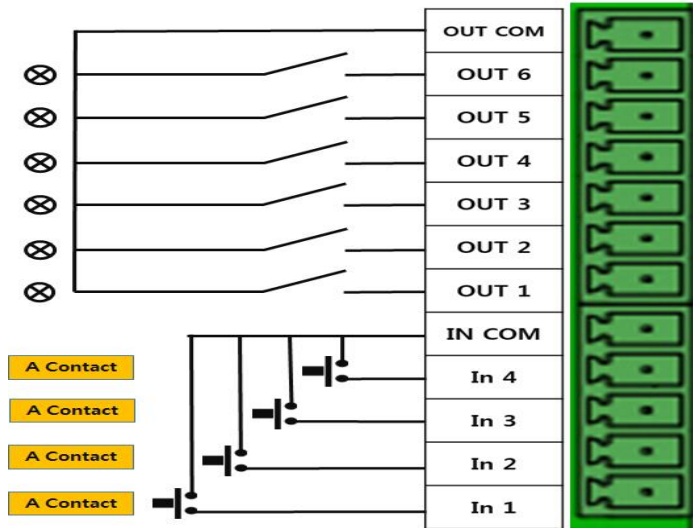

### Output (A Contact)

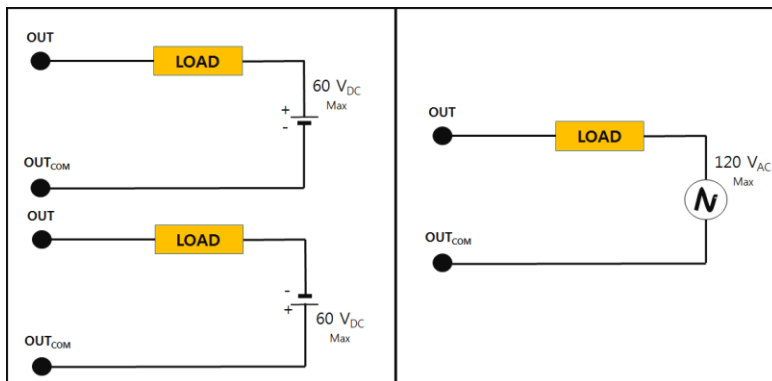

## 8-2 Analog Out

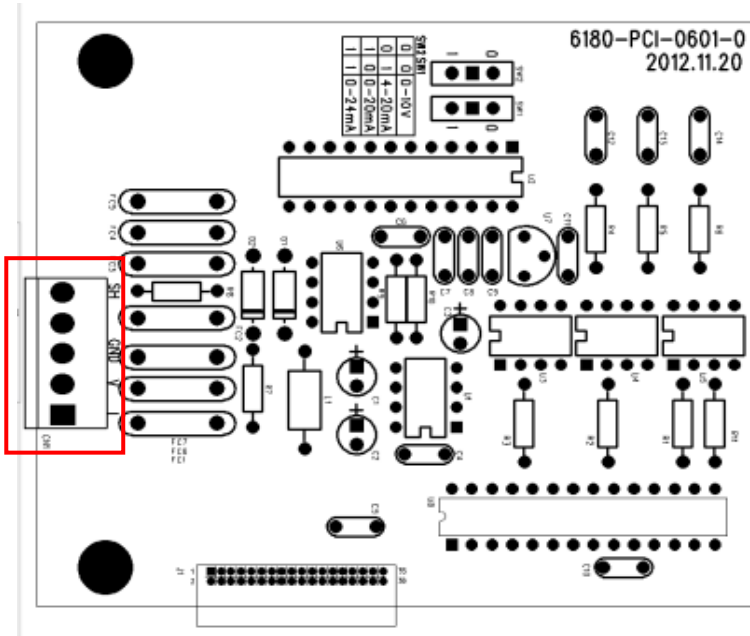

### CN2 Pin Map

Pin No	Signal
1	I-OUT
2	V-OUT
3	GND
4	NC
5	SHILED

### General

- V-Out 0~10V
- I-Out 0~20mA
- I-Out 0~24mA
- I-Out 4~20mA
- Fixing / Flexibility Setting
- Operating temperature range : -10°C ~40°C
- Connector\_ Terminal Block - 5 Pin

► SPECIFICATIONS

	Output	Precision	Max. Impedance
V-OUT	0~10V(DC)	Over 1/1000	-
I-OUT	0~24mA	Over 1/1000	500Ω MAX

► V-out Equivalent Circuit

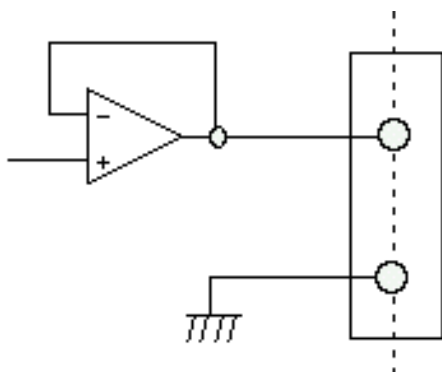

► I-out Equivalent Circuit

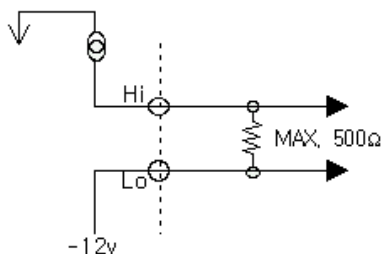

※ V-out output puts out Analog voltages(0~10V) proportional to the signal input displaying the weight

※ I-out output is adjusted so as to be 4 mA when the weight display is 0, and 20 mA when it is the maximum load,

► Lo(-) terminal is not GND, it should not be connected to GND line or body GND of of some other equipment or similar apparatus

► Adjust F4-01, F4-02 if the range of the output values needs to be adjusted.

## 8-3 BCD-OUT

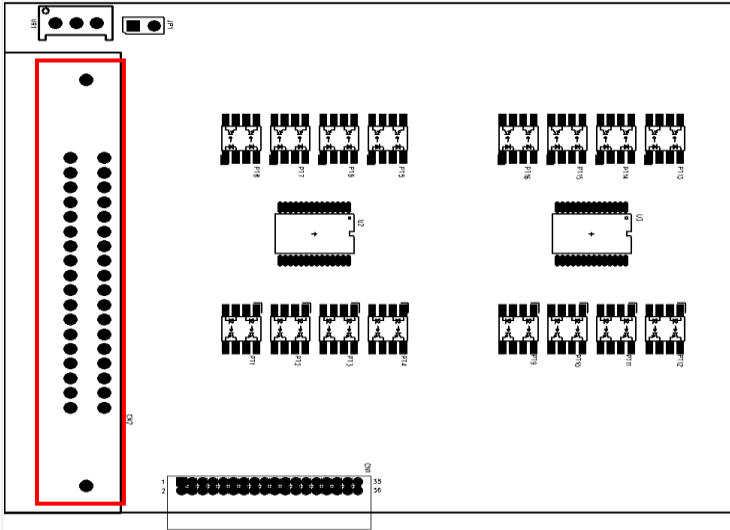

### CN2 Connection Diagram

▶ Only use in NPN Type of PLC

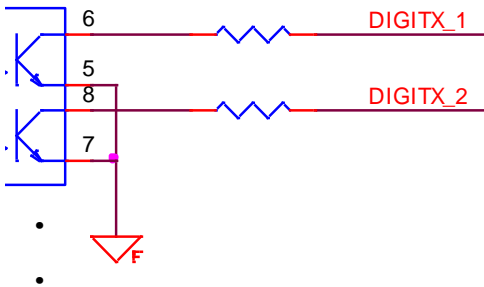

### ■ General

- Operating temperature range : -10 °C ~ 40 °C
- Connector \_ DB-36Pin (CHAMP 57-40360(Ampheno-Female))

The Parallel BCD out is the interface that indicates the weight in display as BCD code  
 The Inner circuit of input/output circuit is electronically disconnected by photo coupler

## CN2 Pin Map

Pin No	Signal	Pin No	Signal
1	1st Digit - $1 \times 10^0$	19	5th Digit - $1 \times 10^4$
2	1st Digit - $2 \times 10^0$	20	5th Digit - $2 \times 10^4$
3	1st Digit - $4 \times 10^0$	21	5th Digit - $4 \times 10^4$
4	1st Digit - $8 \times 10^0$	22	5th Digit - $8 \times 10^4$
5	2nd Digit - $1 \times 10^1$	23	6th Digit - $1 \times 10^5$
6	2nd Digit - $2 \times 10^1$	24	6th Digit - $2 \times 10^5$
7	2nd Digit - $4 \times 10^1$	25	6th Digit - $4 \times 10^5$
8	2nd Digit - $8 \times 10^1$	26	6th Digit - $8 \times 10^5$
9	Ground(GND)	27	High : Gross, Low : Net
10	Ground(GND)	28	High : +, Low : - (Weight)
11	3th Digit - $1 \times 10^2$	29	High = Overload
12	3th Digit - $2 \times 10^2$	30	N.C.
13	3th Digit - $4 \times 10^2$	31	Dot Position : $10^1$
14	3th Digit - $8 \times 10^2$	32	Dot Position : $10^2$
15	4th Digit - $1 \times 10^3$	33	Dot Position : $10^3$
16	4th Digit - $2 \times 10^3$	34	N.C.
17	4th Digit - $4 \times 10^3$	35	N.C.
18	4th Digit - $8 \times 10^3$	36	N.C.

## 8-4 BCD-IN

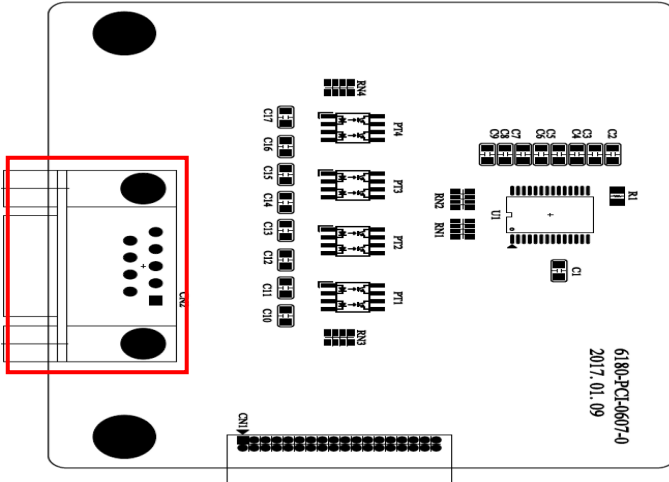

## CN2 Connection Diagram

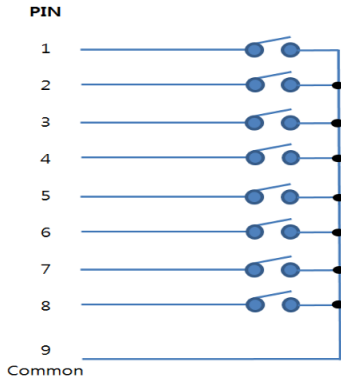

## General

- Operating temperature range : -10°C ~ 40°C
- Connector \_D-SUB-9 Pin(Female)

User can changing the Item code through BCD In card  
 The Inner circuit is disconnected electronically by photo coupler.

## CN2 Pin Map

Pin No.	Signal	Pin No.	Signal
1	1st Digit - $1 \times 10^0$	5	2nd Digit - $1 \times 10^1$
2	1st Digit - $2 \times 10^0$	6	2nd Digit - $2 \times 10^1$
3	1st Digit - $4 \times 10^0$	7	2nd Digit - $4 \times 10^1$
4	1st Digit - $8 \times 10^0$	8	2nd Digit - $8 \times 10^1$
9	Ground (GND)		

# 9. Serial Communication

## 9-1 RS-232C Port Connection

### ① PC Connect

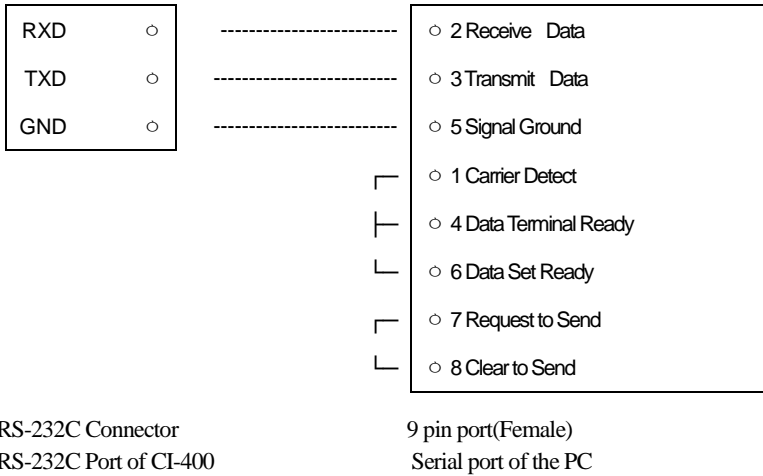
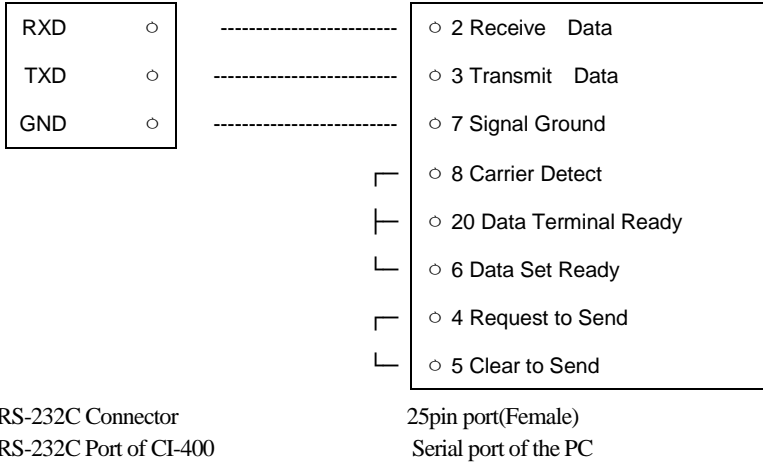

## ② How to Connect a Label Printer (DLP)

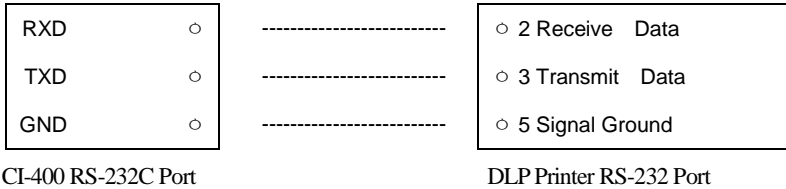

## 9-2 Current loop

Current Loop Interface has stronger resistance to electric noise than the RS-232C Interface; therefore, it is more favorable for intermediate-distance transmissions. (approximately 100M)

### ► Output Method & Format

Same as RS-232C above

### - Current Loop Connect Diagram -

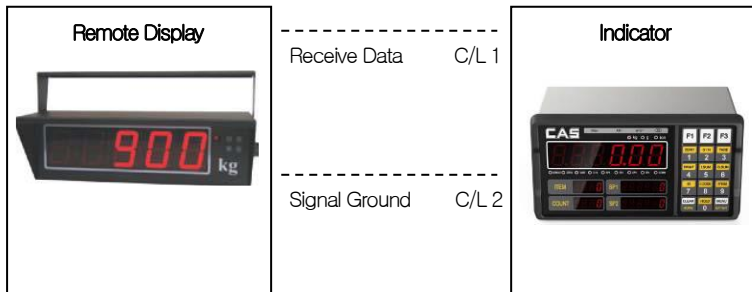

### 9-3 RS-422/RS-485 Serial Communication (Option)

RS-422 & 485 transmit signals with the voltage difference, which are more stable for electric noises than other communication methods.

In addition, the AC power cable or other electric wires should be placed separately, and the shield cable (0.5Φ or more) dedicated to communications should be applied the recommended use distance is within 1.2km.

► **Output Method & Format**

Same as RS-232C above

**- RS-422 / RS-485 Connect Diagram -**

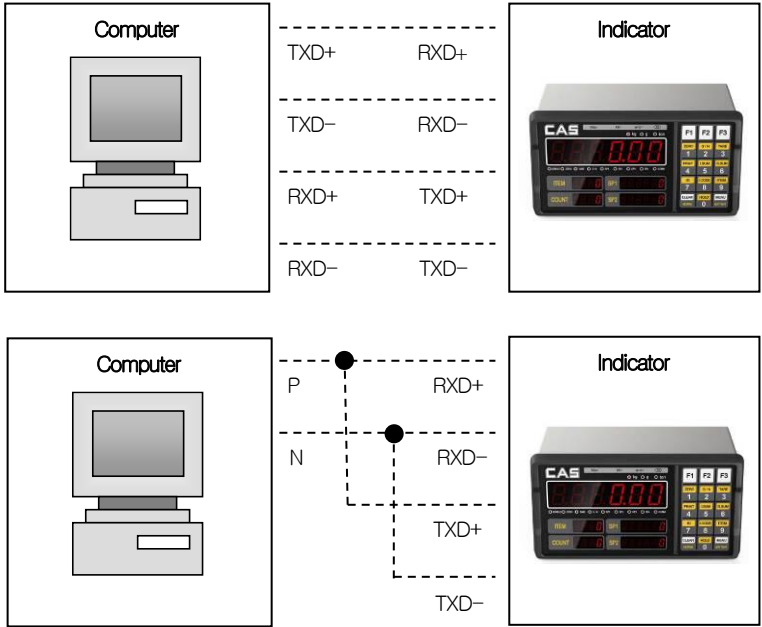



\*Weight Date (8 byte)

Example weight	Byte No							
	1	2	3	4	5	6	7	8
13.5kg	''	''	''	''	'1'	'3'	'.'	'5'
135kg	''	''	''	''	'1'	'3'	'5'	''
-135kg	'-'	''	''	''	'1'	'3'	'5'	''

## Appendix 2> Command Mode 1 Description

### CAS <NT-500 Command>

Indicator Reception	Function	Indicator Response
ddRWCR LF	Request for Weight Data	Transmit the data in the set format upon command input
ddMZCR LF	Same as Zero Key	Execute the zero and retransmit dd MZ CR LF to PC upon command input
ddMTCR LF	Same as Tare Key	Execute tare and retransmit dd MT CR LF to PC upon command input
ddPN00CR LF	Input Item No.(00-50)	Change the item no. and retransmit dd PN 00 CR LF to PC upon command input.
ddOPCR LF	Same as Start Key	Execute the start and retransmit dd OP CR LF to PC upon command input
ddEMCR LF	Same as Stop Key	Execute the stop and retransmit dd EM CR LF to PC upon command input

\* dd : Device ID. (ASCII Code : 0x30(hex), 0x31(hex if the Device ID is "01"))

\* 00000,00 : Set value for upper limit/lower limit/upper limit fall/lower limit fall  
(ASCII Code : 0x30(hex), 0x30(hex), 0x33(hex), 0x34(hex),  
0x35(hex) if the set value is "00345")

\* When it fails to execute the command : ! CR LF is transmitted to the computer.

\* When there is an error in the command : ? CR LF is transmitted to the computer.

## Appendix 3> Command Mode 2 Description

### CAS <NT-570 Command>

#### Reference 1. Command Mode Table

Command data to NT-570A											Command description	NT-570A Respond	
0	1	2	3	4	5	6	7	8	9	10			11
D	ID	K	Z	CR	LF							ZERO key	
D	ID	K	T	CR	LF							TARE key	Return the received
D	ID	K	G	CR	LF							GROSS key	Return the received
D	ID	K	N	CR	LF							NET key	Return the received
D	ID	K	S	CR	LF							START key	Return the received
D	ID	K	P	CR	LF							STOP key	Return the received
D	ID	K	B	CR	LF							Print key	Return the received
D	ID	K	C	CR	LF							Total print key	Return the received
D	ID	K	W	CR	LF							Request weight data	Return the received
D	ID	H	T	CR	LF							Request set point value	Send Format 2
D	ID	S	1	0	0	0	0	0	0	CR	LF	1 <sup>st</sup> Step value	Return the received
D	ID	S	2	0	0	0	0	0	0	CR	LF	2nd Step value	Return the received
D	ID	S	3	0	0	0	0	0	0	CR	LF	3rd Step value	Return the received
D	ID	S	4	0	0	0	0	0	0	CR	LF	4th Step value	Return the received
D	ID	S	5	0	0	0	0	0	0	CR	LF	High limit value	Return the received
D	ID	S	6	0	0	0	0	0	0	CR	LF	Low limit value	Return the received
D	ID	H	E	0	0	0	0	0	0	CR	LF	Set point code(00-99)	Return the received

(D, ID:00-99, CR : 0×13, LF: 0×10)

#### \* Format 1 : PC send set point all data to indicator NT-580A

0	1	2	3	4	5	6	7	8	9	10	11	12	13	14	15	16	17	18	19		
D	ID	H	A	Set Point code						,	SP	SP	SP	SP	SP	SP	SP	..	Optional-		
20	21	22	23	24	25	26	27	28	29	30	31	32	33	34	35	36	37	38	39		
		Preliminary						Final value								Free Fall					
40	41	42	43	44	45	46	47	48	49	50	51	52	53								
		High limit						Low limit				CR		LF							

#### \* Format 2 : Recieve the request data from PC then response of Indicator

0	1	2	3	4	5	6	7	8	9	10	11	12	13	14	15	16	17	18	19		
D	ID	H	T	Set Point code						,	SP	SP	SP	SP	SP	SP	SP	..	Optional-		
20	21	22	23	24	25	26	27	28	29	30	31	32	33	34	35	36	37	38	39		
		Preliminary						Final value								Free Fall					
40	41	42	43	44	45	46	47	48	49	50	51	52	53								
		High limit						Low limit				CR		LF							

\* Please input without the decimal point.

## Appendix 4> Command mode 3 Description

CI-400 : Transmission only if data is requested ( 1 byte communication)

## Appendix 5> ASCII Table

CHA	CODE	CHA	CODE	CHA	CODE	CHA	CODE	CHA	CODE	CHA	CODE
Space	32	0	48	@	64	P	80	`	96	p	112
!	33	1	49	A	65	Q	81	a	97	q	113
“	34	2	50	B	66	R	82	b	98	r	114
#	35	3	51	C	67	S	83	c	99	s	115
\$	36	4	52	D	68	T	84	d	100	t	116
%	37	5	53	E	69	U	85	e	101	u	117
&	38	6	54	F	70	V	86	f	102	v	118
‘	39	7	55	G	71	W	87	g	103	w	119
(	40	8	56	H	72	X	88	h	104	x	120
)	41	9	57	I	73	Y	89	i	105	y	121
*	42	:	58	J	74	Z	90	j	106	z	122
+	43	;	59	K	75	[	91	k	107	{	123
,	44	<	60	L	76	\	92	l	108		124
-	45	=	61	M	77	]	93	m	109	}	125
.	46	>	62	N	78	^	94	n	110	~	126
/	47	?	63	O	79	_	95	o	111	End	0

## Appendix 6>MODBUS-RTU PROTOCOL

The registry read and write shown below of MODBUS-RTU protocol can be managed based on the requirements included in the reference document regarding the **Modicon PI-MBUS-300** standard.

For selection of communication with Modbus-RTU, the serial communication settings paragraph has been included.

If specific data has been recorded directly in EEPROM type memory, it is recommended that unnecessary work at the aforementioned position be avoided as the memory is limited in its write activation (100,000).

The below number is, when coming after 0x, is described in a decimal or a hexadecimal method.

### MODBUS-RTU DATA FORMAT

Data transferred by the Modbus-RTU protocol has the following characteristics.

- Start bit 1
- Data bit 8 (smallest bit sent first)
- Parity bit setting (instrument setting)
- Stop bit setting (instrument setting)

### MODBUS SUPPORTED FUNCTIONS

From the commands capable of being used in the Modbus-RTU protocol, only the following are used in communication management with the instrument. Other commands may not be accurately interpreted and may cause error or shutdown the system.

Function	Explanation
03(0x03)	READ HOLDING REGISTER
16(0x10)	PRESET MULTIPLE REGISTERS

The request cycle is integrated with the preset communication speed. (The instrument requires a transfer delay of at least 3 bytes to reply to the request)

Delay parameters exist in the serial communication setting, and directly affect the number of request possible in a unit time by additionally delaying the reply from the instrument.

For additional information about this protocol, refer to the PI\_MBUS\_300 normal technical specifications.

Typically, the request and reply for the slave instrument is composed as follows.

### FUNCTION 3: Read holding registers

#### Request

Address	Function	Register1 Address	No. register	2 bytes
A	0x03	0x0000	0x0002	CRC

Total. bytes = 8

#### Reply

Address	Function	No.byte	Register1	Register2	2 bytes
A	0x03	0x04	0x0064	0x00C8	CRC

Total. bytes = 3 + 2\*No. register + 2

-number of register = number of modbus register to be read, start at address 1 register.

-number of byte = number of bytes in the following data

### FUNCTION 16: Preset multiple registers

#### Request

Addr	Function	Add. Reg.1	No.reg.	No. bytes	Val. Reg. 1	Val. Reg. 2	2 bytes
A	0x10	0x0000	0x0002	0x4	0x0000	0x0000	CRC

Total. bytes = 7 + 2\*No. register + 2

#### Reply

Address	Function	Add.Reg.1	No.reg.	2 bytes
A	0x10	0x0000	0x0002	CRC

Total. bytes = 8

-No. registers = number of modbus register to be read, start at address 1 register

-No. bytes = Number of following data bytes

-Val.reg.1 = Content of starting register

In the reply, the number of converted redcodes starting from address 1 is included.

## Communication Error Management

The management of communication data error must be controlled by CRC (cycle redundancy check).

If a communication error occurs, the slave does not reply to any request.

The master must consider the time-out before receiving the reply. If no reply is received, it can be inferred that a communication error has occurred.

If the data strings have been accurately received but cannot be executed, an exceptional response is required. The contents are as follows.

### Exceptional response

Address	Function	Code	2bytes
A	Funct + 0x80		CRC

CODE	DESCRIPTION
1	Invalid or unsupported function (ILLEGAL FUNCTION)
2	When the stated data address cannot be used (ILLEGAL DATA ADDRESS)
3	When the received data value is invalid (ILLEGAL DATA VALUE )
4	Error in the CRC code (CRC Error)

## Register List

The Modbus-RTU protocol registers capable of being executed in this instrument are as follows.

**R** = Register that can be used as read-only

**W** = Register that can be used as write-only

**R/W** = Register that can be used as for both read and write

**H** = Higher word of the Double word composing the register

**L** = Lower word of the Double word composing the register

REGISTER	DESCRIPTION	Input value	Saving to EEPROM	ACCESS
40002	Type of instrument	-	-	R
40008	GROSS WEIGHT H	-	-	R
40009	GROSS WEIGHT L	-	-	R
40010	NET WEIGHT H	-	-	R
40011	NET WEIGHT L	-	-	R
40014	Raw AD Data_H	-	-	R
40015	Raw AD Data_L	-	-	R
40017	Set point 1 H	0~99999	Y	R/W
40018	Set point 1 L	0~99999	Y	R/W
40019	Set point 2 H	0~99999	Y	R/W
40020	Set point 2 L	0~99999	Y	R/W
40021	Set point 3 H	0~99999	Y	R/W
40022	Set point 3 L	0~99999	Y	R/W
40023	Set point 4 H	0~99999	Y	R/W
40024	Set point 4 L	0~99999	Y	R/W
40037	Ext_Input	-	-	R/W

40038	Ext_Output	-	-	R/W
40042	Analog out Span Weight H	0~99999	Y	R/W
40043	Analog out Span Weight L	0~99999	Y	R/W
40044	Analog out Zero Adjust H	0~99999	Y	R/W
40045	Analog out Zero Adjust L	0~99999	Y	R/W
40046	Analog out Span Adjust H	0~99999	Y	R/W
40047	Analog out Span Adjust L	0~99999	Y	R/W
40050	Analog Out V-Out range Setting	0~99999		
40051	Analog Out I-Out range Setting	0~99999		
40052	Analog Out Dual-Out range Setting	0~99999		
40060	ADC Speed	0~99999	Y	R/W
40062	AD Filter Size	0~99999	Y	R/W
40063	Set Low pass filter	0 : OFF 1 : ON	Y	R/W
40064	Order of Low pass filter	2~4	Y	R/W
40065	Cut frequency of Low pass filter	1~100	Y	R/W
40066	Set Band stop filter	0 : OFF 1 : ON	Y	R/W
40067	High cut Frequency of Band stop filter	1~100	Y	R/W
40068	Low cut Frequency of Band stop filter	1~100	Y	R/W
40069 ~ 40080	Reserved		-	-
40053	Ext_Input		Y	R/W
40060	Ext_Output		Y	R/W
40062	Analog out Span Weight H		Y	R/W
40063	ADC reserved		-	-
40064	ADC reserved		-	-
40065	ADC reserved		-	-

40066	ADC reserved		-	-
40067	ADC reserved		-	-
40068	ADC reserved		-	-
40081	Stable range	0~99	Y	R/W
40082	Zero tracking range	0~9	Y	R/W
40083	Weight back up	0 : OFF 1 : ON	Y	R/W
40084	Zero key range	0~99	Y	R/W
40085	Tare key range	0~99	Y	R/W
40086	Initial zero range	0~99	Y	R/W
40087	Overload range	0~9	Y	R/W
40088	reserved		-	-
40089	Zero, Tare, Gross/Net, Hold, Tare Clear, Hold Clear	1 : Zero 2 : Tare 3 : Gross/Net 4 : Hold 5 : Tare Clear 6 : Hold Clear	Y	W
40090	reserved		-	-
40151	Device Number		Y	R/W
40152	Comm transmit time		Y	R/W
40153	COM1's parity bit		Y	R/W
40154	COM1's Baudrate		Y	R/W
40155	COM1's output data(Gross/Net)		Y	R/W
40156	COM1's output format		Y	R/W
40157	COM1's output mode		Y	R/W
40158 ~ 40170	reserved		-	-
40171	Set Year		Y	R/W
40172	Set Month		Y	R/W

40173	Set Date		Y	R/W
40174	Set Hour		Y	R/W
40175	Set Minute		Y	R/W
40176	Set Second		Y	R/W
40177	Set use Alibi memory		Y	R/W
40178 ~ 40199	reserved		-	-

## 11. Error Message

### 11-1 Errors that can occur in weight calibration mode

Error	Cause	Solution
<b>Err 20</b>	The set resolution has exceeded the allowance limit of 1/30,000.	Lower resolution. Resolution = maximum allowed weight/value of 1 increment. Adjust maximum allowed weight in CAL 1 of weight calibration mode or adjust the value of 1 increment in CAL 3 of weight calibration mode to adjust to below 1/30,000.
<b>Err 22</b>	The counterweight for span adjustment has been set to less than 10% of maximum weighing scale capacity.	Set the counterweight weight as greater than 10% of the maximum scale capacity (set in CAL 1) in CAL 4 of weight calibration mode.
<b>Err 23</b>	The counterweight for span adjustment has been set to exceed 100% of the weighing scale capacity.	Set the counterweight weight to within the maximum weighing scale capacity (set in CAL 1) in CAL 4 of weight calibration mode.
<b>Err 24</b>	Span is too low.	Setting the present resolution is not possible as there is an issue with the load cell or the load cell output is too small. Reset the weight calibration by reducing the resolution. PCS, PERCENT Sample weight is too small
<b>Err 25</b>	Span is too high.	There is an issue with the load cell or the load cell output is too high. Redo steps from weight setting CAL 4 zero-set adjustment. PCS, PERCENT Sample weight is too great.
<b>Err 26</b>	Zero-set is too high.	Check if the load plate of the weighing scale is clear. After verifying in Test Mode 3, redo the weight calibration.
<b>Err 27</b>	Zero-set is too low.	After checking the force applied to the weighing scale load plate in Test Mode 3, redo the weight calibration.
<b>Err 28</b>	Weight is unstable.	Check if the load cell connector is properly connected.

## 11-2 Errors that can occur in weighing mode

<b>Error</b>	<b>Cause</b>	<b>Solution</b>
<b>Err 01</b>	Due to unstable load the weighing scale cannot be reset.	Move the weighing scale to a flat, vibration-free surface and turn on the power.
<b>Err 02</b>	Load cell is not properly connected or there is a problem with the A/D convertor.	Check if the main body and the load plate are connected properly.
<b>Err 08</b>	The zero-set key, container key and start key are set not to function when the load is unstable.	In F22 of the Conversion Mode, set the zero-set key, container key and start key activation conditions based on the environment of use.
<b>Err 09</b>	The current weight exceeds the zero-set range.	In F09 of Conversion Mode set the activation range to within 2% or 10% of the maximum capacity.
<b>Err 10</b>	The weight of the container being designated exceeds the maximum capacity of the weighing scale.	Set the container weight to be less than the maximum capacity.
<b>Err 13</b>	When calibrating the weight the set zero-set has been exceeded.	Check the status of the load plate and redo the weight calibrations.
<b>Err 15</b>	In Command Mode, the Item Code has exceeded the set range.	Check the Item Code range
<b>Err 82</b>	There is a problem with the A/D convertor.	Please contact the A/S center.
<b>OVER</b>	The current load on the load plate is too heavy, and exceeds the allowance limit.	Do not place weight exceeding the capacity limit on the weighing scale. If the load cell is damaged, it must be replaced.

# MEMO

# MEMO



# MEMO

# CI-400 SERIES

Weighing Indicator



CAS BLDG., #1315, YANGJAE-DAERO,  
GANGDONG-GU, SEOUL, KOREA

TEL\_ 82 2 2225 3500

FAX\_ 82 2 475 4668

[www.globalcas.com](http://www.globalcas.com)