

CL3000 SERIES

Label Printing Scale



www.globalcas.com

OWNER'S MANUAL

CAS

CONTENTS

| | |
|---|----|
| 1. GENERAL | 10 |
| 1.1 Precautions | 10 |
| 1.2 Introductions | 12 |
| 1.3 Specifications | 13 |
| 1.4 Name and Functions | 15 |
| 1.5 Symbols | 22 |
| 1.6 Key Functions | 23 |
| 1.7 Installation of the Label Roll | 27 |
| 2. PROGRAMMING | 29 |
| 2.1 PLU Programming | 34 |
| 2.1.1 Create By-Weight PLU (Menu code 1120) | 36 |
| 2.1.2 Create By-Count PLU (Menu code 1120) | 43 |
| 2.1.3 Create By-PCS PLU (Menu code 1120) | 45 |
| 2.1.4 Editing PLU (Menu code 1120) | 46 |
| 2.1.5 Sample Printing (Menu code 1170) | 46 |
| 2.1.6 Listing PLU (Menu code 1150) | 46 |
| 2.1.7 Copying PLU (Menu code 1141) | 47 |
| 2.1.8 Deleting PLU (Menu code 1142) | 47 |
| 2.1.9 Moving PLU (Menu code 1143) | 48 |
| 2.1.10 Selecting PLU field Items (Menu code 1144) | 48 |
| 2.1.11 PLU Sale Count (Menu code 1145) | 49 |
| 2.2. Programming PLU Data Table I | 50 |
| 2.2.1 Department (Menu code 1210) | 50 |
| 2.2.2 New/Edit Department (Menu code 1211) | 51 |
| 2.2.3 List Department (Menu code 1212) | 51 |
| 2.2.4 Delete Department (Menu code 1213) | 52 |
| 2.2.5 Group (Menu code 1220) | 52 |
| 2.2.6 New/Edit Group (Menu code 1221) | 52 |
| 2.2.7 List Group (Menu code 1222) | 53 |
| 2.2.8 Delete Group (Menu code 1223) | 53 |
| 2.2.9 Tax Rate (Menu code 1230) | 53 |
| 2.2.10 New/Edit Tax Rate (Menu code 1231) | 54 |
| 2.2.11 List Tax Rate (Menu code 1232) | 55 |
| 2.2.12 Delete Tax Rate (Menu code 1233) | 55 |
| 2.2.13 Sales Message (Menu code 1240) | 55 |

| | |
|---|----|
| 2.2.14 New/Edit Sales Message (Menu code 1241) | 56 |
| 2.2.15 List Sales Message (Menu code 1242) | 56 |
| 2.2.16 Delete Sales Message (Menu code 1243) | 57 |
| 2.2.17 Origin (Menu code 1250) | 57 |
| 2.2.18 New/Edit Origin (Menu code 1251) | 57 |
| 2.2.19 List Origin (Menu code 1252) | 58 |
| 2.2.20 Delete Origin (Menu code 1253) | 58 |
| 2.2.21 Barcode (Menu code 1260) | 58 |
| 2.2.22 New/Edit Barcode (Menu code 1261) | 58 |
| 2.2.23 List Barcode (Menu code 1262) | 61 |
| 2.2.24 Delete Barcode (Menu code 1263) | 61 |
| 2.2.25 Tare (Menu code 1270) | 62 |
| 2.2.26 New/Edit Tare (Menu code 1271) | 62 |
| 2.2.27 List Tare (Menu code 1272) | 63 |
| 2.2.28 Delete Tare (Menu code 1273) | 63 |
| 2.2.29 Tare Key (Menu code 1274) | 64 |
| 2.2.30 Unit Symbol (Menu code 1280) | 64 |
| 2.2.31 New/Edit Unit Symbol (Menu code 1281) | 64 |
| 2.2.32 List Unit Symbol (Menu code 1282) | 65 |
| 2.2.33 Delete Unit Symbol (Menu code 1283) | 65 |
| 2.3 Programming PLU Data Table II | 66 |
| 2.3.1 Ingredient (Menu code 1310) | 66 |
| 2.3.2 New/Edit Ingredient (Menu code 1311) | 66 |
| 2.3.3 List Ingredient (Menu code 1312) | 67 |
| 2.3.4 Delete Ingredient (Menu code 1313) | 67 |
| 2.3.5 Nutrition Facts (Menu code 1320) | 67 |
| 2.3.6 New/Edit Nutrition Facts (Menu code 1321) | 68 |
| 2.3.7 List Nutrition Facts (Menu code 1322) | 72 |
| 2.3.8 Delete Nutrition Facts (Menu code 1323) | 72 |
| 2.4 Discount Programming | 73 |
| 2.4.1 Discount (Menu code 1130) | 73 |
| 2.4.2 New/Edit Discount (Menu code 1131) | 73 |
| 2.4.3 List Discount (Menu code 1132) | 76 |
| 2.4.4 Delete Discount (Menu code 1133) | 77 |
| 2.4.5 Delete by PLU No. (DC) (Menu code 1137) | 77 |
| 2.4.6 Delete by Dept. No. (DC) (Menu code 1138) | 77 |
| 2.4.7 Delete ALL (DC) (Menu code 1139) | 78 |

| | |
|---|-----|
| 2.5 Global Discount Programming..... | 79 |
| 2.5.1 Global Discount (Menu code 1530)..... | 79 |
| 2.5.2 Priority Setting (Menu code 1531)..... | 79 |
| 2.5.3 Weight/Count/PCS Discount (Menu code 1532/1533/1534)..... | 80 |
| 2.6 Speed Key Setting (Menu code 1160)..... | 81 |
| 2.6.1 Speed Key(Menu code 1160)..... | 79 |
| 2.7 Programming Store Data..... | 91 |
| 2.7.1 Store Data (Menu code 1410)..... | 91 |
| 2.7.2 New/Edit Store (Menu code 1411)..... | 91 |
| 2.7.3 List Store (Menu code 1412)..... | 92 |
| 2.7.4 Delete Store (Menu code 1413)..... | 92 |
| 2.7.5 Customer (Menu code 1420)..... | 93 |
| 2.7.6 New/Edit Customer (Menu code 1421)..... | 93 |
| 2.7.7 List Customer (Menu code 1422)..... | 94 |
| 2.7.8 Delete Customer (Menu code 1423)..... | 94 |
| 2.7.9 Scroll Message (Menu code 1430)..... | 95 |
| 2.7.10. Configuration (Menu Code 1431)..... | 95 |
| 2.7.11. Edit Scroll Message (Menu Code 1432)..... | 95 |
| 2.7.12. List Scroll Message (Menu Code 1433)..... | 97 |
| 2.7.13 Currency (Menu code 1440)..... | 97 |
| 2.7.14. New/Edit Currency (Menu Code 1441)..... | 98 |
| 2.7.15. List Currency (Menu Code 1442)..... | 99 |
| 2.7.16 Delete Currency (Menu code 1443)..... | 101 |
| 2.8 Programming Global Setting..... | 104 |
| 2.8.1 Global Label Format (Menu code 1510)..... | 104 |
| 2.8.2 Barcode Format (Menu code 1520)..... | 105 |
| 2.9 Printing Programming..... | 109 |
| 2.9.1 Printing (Menu code 1700)..... | 109 |
| 2.9.2 Print label item (Menu code 1710)..... | 109 |
| 2.9.3 Markdown (Menu code 1720)..... | 111 |
| 2.9.4 Printer Hardware (Menu code 1730)..... | 111 |
| 2.9.5 Print Mode (Menu code 1731)..... | 113 |
| 2.9.6 Label Size/Ticket Size (Menu code 1732)..... | 113 |
| 2.9.7 Sensor Calibration (Menu code 1733)..... | 113 |
| 2.9.8 Sensor & Motor (Menu code 1734)..... | 114 |
| 2.9.9 Print Intensity (Menu code 1735)..... | 114 |
| 2.9.10 Adjust Feed Length (Menu code 1736)..... | 114 |
| 2.9.11 Label Preprint (Menu code 1737)..... | 115 |
| 2.9.12 Label Preprint (Menu code 1738)..... | 115 |
| 2.9.13 Serial Number Format (Menu code 1740)..... | 115 |
| 2.9.14 Add-Up Total (Menu code 1750)..... | 116 |
| 2.9.15 Ticket (Menu code 1760)..... | 117 |
| 2.9.16 Select Ticket Item (Menu code 1761)..... | 117 |

| | |
|---|------------|
| 2.9.17 Select List Item (Menu code 1762) | 118 |
| 2.9.18 Select Ticket Item (Menu code 1763)..... | 118 |
| 2.10 Programming Scale Configuration | 120 |
| 2.10.1. Scale Configuration (Menu code 1800)..... | 120 |
| 2.10.2 Sale Mode (Menu code 1810) | 120 |
| 2.10.3 Operation Mode (Menu code 1820)..... | 121 |
| 2.10.4 Department (Menu code 1830)..... | 122 |
| 2.10.5 Date & Time (Menu code 1840)..... | 123 |
| 2.10.6 User/ Security Configuration (Menu code 1850)..... | 124 |
| 2.10.7 New/Edit User(Menu code 1851)..... | 124 |
| 2.10.8 Change Password (Menu code 1852)..... | 125 |
| 2.10.9 List User (Menu code 1853)..... | 126 |
| 2.10.10 Delete User (Menu code 1854)..... | 126 |
| 2.10.11 Config Permission (Menu code 1855)..... | 126 |
| 2.10.12 Clerk Key (Menu code 1856) | 129 |
| 2.10.13 Test (Menu code 1860)..... | 129 |
| 2.10.14 Display Test (Menu code 1861) | 130 |
| 2.10.15 A/D Test (Menu code 1862)..... | 130 |
| 2.10.16 Keyboard Test (Menu code 1863)..... | 130 |
| 2.10.17 Chess Printer Test (Menu code 1864)..... | 130 |
| 2.10.18 Printer Sensor Test (Menu code 1865)..... | 131 |
| 2.10.19 Memory Information (Menu code 1866)..... | 131 |
| 2.10.20 Firmware Version (Menu code 1867)..... | 131 |
| 2.10.21 Scale Parameter (Menu code 1870) | 132 |
| 2.10.22 Function Key Define (Menu code 1880)..... | 134 |
| 2.11 Report | 137 |
| 2.11.1 Introduction..... | 137 |
| 2.11.2 Report Menu (Menu code 1600)..... | 137 |
| 2.11.3 X1/X2 Report (Menu code 1610/1630)..... | 138 |
| 2.11.4 X1/X2 Scale Sales Report (Menu code 1611/1613)..... | 138 |
| 2.11.5 X1/X2 PLU Report (Menu code 1612/1632) | 140 |
| 2.11.6 X1/X2 Miscellaneous PLU Report (Menu code 1613/1633) | 142 |
| 2.11.7 X1/X2 Group Report (Menu code 1614/1644)..... | 144 |
| 2.11.8 X1/X2 Department Sales Report (Menu code 1615/1635)..... | 145 |
| 2.11.9 X1/X2 Hourly Sales Report (Menu code 1616/1636)..... | 147 |
| 2.11.10 X1/X2 Clerk Sales Report (Menu code 1617/1637) | 149 |
| 2.11.11 Z1/Z2 Report (Menu code 1620/1640)..... | 152 |
| 2.11.12 Clear All Report (Menu code 1650) | 153 |
| 3. SALES OPERATION..... | 154 |
| 3.1 Basic Operation | 154 |
| 3.2 Zero | 155 |

| | |
|--|-----|
| 3.3 Tare | 156 |
| 3.3.1 Manual Tare Entry 1 | 156 |
| 3.3.2 Weighed Tare Entry | 156 |
| 3.3.3 How to Clear Tare..... | 157 |
| 3.3.4 Preset Tare | 157 |
| 3.3.5 Successive Tare..... | 157 |
| 3.3.6 Tare Override..... | 158 |
| 3.4 Calling Up a PLU | 159 |
| 3.4.1 Using Numeric Key..... | 159 |
| 3.4.2 Using Speed Key | 159 |
| 3.5 Override (FOR key)..... | 160 |
| 3.5.1 By-Weight PLU..... | 160 |
| 3.5.2 By-Count PLU | 161 |
| 3.5.3 By-PCS PLU..... | 162 |
| 3.6 Sales Operation | 163 |
| 3.6.1 Weighed Item Operation | 163 |
| 3.6.2 By Count Item | 164 |
| 3.6.3 By PCS Item | 165 |
| 3.7 Discount | 166 |
| 3.7.1 Unit Price Discount - By Weight PLU | 166 |
| 3.7.2 % Unit Price Discount - By Weight PLU..... | 167 |
| 3.7.3 Unit Price Discount - By PCS PLU | 169 |
| 3.8 Add-Up Transaction | 170 |
| 3.9 Clerk Operation..... | 172 |
| 3.9.1 Standard Clerk Operation..... | 173 |
| 3.9.2 Floating Clerk Operations | 174 |
| 3.10 Void..... | 176 |
| 3.11 Payment & Change | 177 |
| 3.12 Return..... | 179 |
| 3.13 Prepack Key | 180 |
| 3.14 X Key | 182 |
| 3.14.1 By-Weight PLU..... | 182 |
| 3.14.2 Non-Weighed PLU..... | 183 |
| 3.15 How to Change Sell By Date/Time..... | 184 |
| 3.16 How to Change Origin..... | 185 |
| 3.17 How to Change PLU Type | 186 |
| 3.18 Direct Discount | 187 |
| 3.18.1 Fixed Price Key | 187 |
| 3.18.2 % Discount Price Key | 188 |

| | |
|--|------------|
| 3.19 PLU Connection | 189 |
| 3.19.1 Referenced PLU Function | 189 |
| 3.19.2 Coupled PLU Function | 189 |
| 3.19.3 Linked PLU Function..... | 189 |
| 3.20 Sales Operation Control Parameters..... | 189 |
| 3.20.1 Fixed Weight..... | 189 |
| 3.20.2 Prepack Without Report | 189 |
| 4. Appendix | 190 |
| 4.1 Label Format..... | 190 |
| 4.2 Fixed Label Format Sample..... | 192 |
| 4.3 Label Field..... | 193 |
| 4.3.1 Item Label Field..... | 193 |
| 4.3.2 Total Label Field | 199 |
| 4.4 ASCII Code Table..... | 201 |
| 4.5. Window Character Set Information..... | 202 |

1.GENERAL

1.1 PRECAUTIONS

Warning

Precautions when installing the scale. To ensure that you get the most from your scale, please follow these instruction.

Do not disassemble the scale.

When any damage or defect occurs, contact your CAS authorized dealer immediately for proper repair.



Do not overload beyond the maximum weight limit.

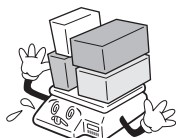

Scale must be grounded to minimize electricity static.

This will minimize defect or electric shock.



Do not pull the plug by its cord when unplugging.

Damaged cord could cause electric shock or fire.



To prevent from fire occurring, Do not place or use the scale near flammable or corrosive gas.

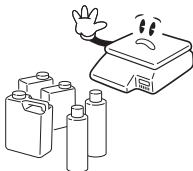

To reduce electric shock or incorrect reading, Do not spill water on the scale or place it in humid condition.



Avoid placing the scale near heater or in direct sunlight.

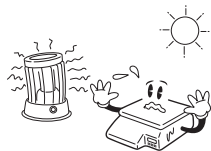

Insert plug firmly to wall outlet to prevent electric shock.

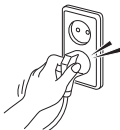

Use proper Adapter.

Incorrect adapter could damage the scale.

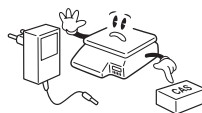

Attention

Make sure to plug your scale into the proper power outlet. For maximum performance, plug into a power outlet 30 minutes before the usage for warm up.

For consistent and accurate reading, maintain periodical check by your CAS authorized dealer.



Avoid sudden shock to the scale.



Grab on the bottom of the scale when moving.



Keep the scale away from other electromagnetic generating devices.

This may interfere with accurate reading.



Place the scale on firm and temperature consistent environment.



By adjusting 4 corners of the scale, set the scale even using the built in scale leveling indicator.

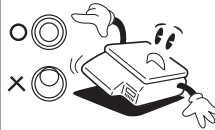

*** This equipment is indoor use and all the communication wirings are limited to inside of the building.**

1.2 INTRODUCTIONS

Thank you for purchasing the CAS CL3000 price computing electronic printing scale. We have designed this equipment with many advanced features, high quality construction, and user-friendly menu driven programming.

We are confident that you will find the CAS CL3000 scale will meet all of your most demanding needs.

Remember, for proper installation and maintenance please have your Authorized CAS Dealer do the primary installation, programming, and demonstration. Your CAS Authorized Dealer also has a wide variety of supplies, accessories, and expansion options for whatever your new and increasing demands may require. Authorized CAS dealers are trained to help you with every aspect of the CL3000 and should you need servicing, they are expertly trained by CAS to assist you with virtually any problem.

1.3 SPECIFICATIONS

| | | | | |
|---------------------|----------------------|----------|---------------|--------------|
| Max. Capacity | 6/15kg | 15/30kg | 15/30 lb | 30/60 lb |
| Interval | 2/5g | 5/10g | 0.005/0.01 lb | 0.01/0.02 lb |
| Max. Tare | -5.998kg | -9.995kg | -9.995 lb | -29.99lb |
| A/D Conversion Rate | Approx. 8 times/sec. | | | |
| Measurement Type | Load Cell | | | |
| Platter Size | 380 x 244 mm | | | |

| | | | | |
|-----------|--|-----------------------------------|---|-----------------------------------|
| Key | Standard Type (B) | 40 PLU key, 30 function key | Pole Type (P) Hanging Type (H) | 72 PLU key, 30 function key |
| Speed Key | | 80 PLU | | 144 PLU |
| Display | Graphic LCD | | | |
| | Preset Tare : 4 digit Weight : 5 digit Unit Price : 6 digit Total Price : 6 digit | | Weight : 5 digit Unit Price : 6 digit Total Price : 7 digit | |

| | |
|---------------------|---|
| Printer | Speed : 100,110 m/sec. |
| Printing Resolution | 202 dpi |
| Label Size | Width: 40mm~60 mm Length: 30mm~100 mm |
| Barcode Type | EAN13, EAN13A5, EAN8, I2OF5, UPCA, UPC13, CODE39, CODE93, CODE128,CODABAR |
| Font | Small, Middle, Large Size, Free Format, Italic, Bold, Underline, Through Line, Double through line, Reverse, shadow, outline |
| Printer Type | DIRECT THERMAL PRINT |

| | |
|-----------------|-----------------------------|
| Operating Temp. | -10°C ~ 40°C (14°F ~ 104°F) |
| Power | AC 180~240V 50/60Hz 1.5A |

| | | Number | Range |
|-------------------|-----------------------------|--------|-------------|
| Programmable Data | PLU | 3000 | 1~99999 |
| | Ingredient 510 character | 999 | 1~999 |
| | User Defined Barcode Format | 99 | 1~99 |
| | Department | 99 | 1~99 |
| | Tax Type | 9 | 1~9 |
| | Group | 99 | 1~99 |
| | Clerk | 31 | 1~31 |
| | Discount | 99 | - |
| | Origin | 499 | 1~499 |
| | Traceability | 99 | 1~99 |
| | Slaughter House | 99 | 1~99 |
| | Cutting Hall | 99 | 1~99 |
| | Traceability Country | 99 | 1~99 |
| | Label Format | 45 | Fixed |
| | | 20 | Free Format |
| | Bitmap Image | 14 | |
| | Customer | 99 | 1~99 |
| | Quantity symbol | 8 | 1~8 |
| | Scroll Message | 9 | 1~9 |
| | X1,X2,Z1,Z2 Report | | |
| Pay Type | 7 | | |
| Sales Message | 99 | 1~99 | |
| Nutrition fact | 99 | 1~99 | |
| Tare Table | 99 | 1~99 | |

| | |
|-------------------|--|
| Sales Period | Dual totals for daily/monthly or user selectable reporting period. |
| Sales Report Mode | Read : X1/X2 Mode, Read & Reset: Z1/Z2 Mode |

Note: Specifications are subject to change without notice.

1.4 NAME AND FUNCTIONS

■ Standard Type

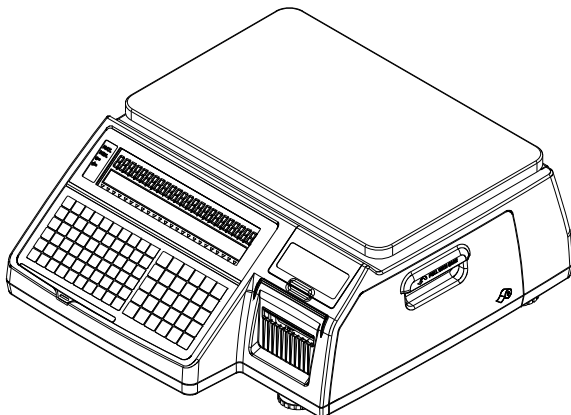

■ Pole Type

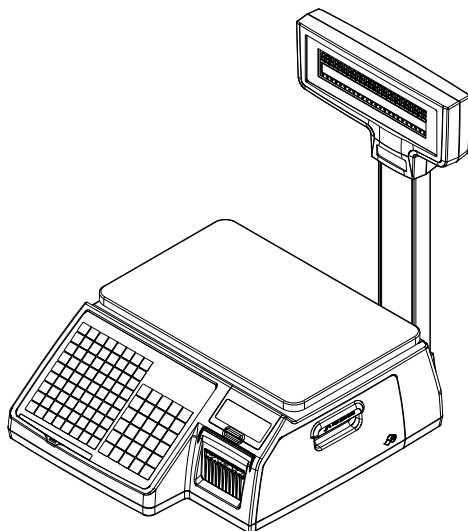

DISPLAY

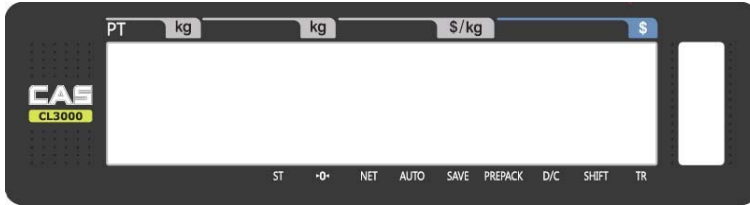

KEYBOARD

B – Type 40PLU (Standard)



B – Type 60PLU (Standard)





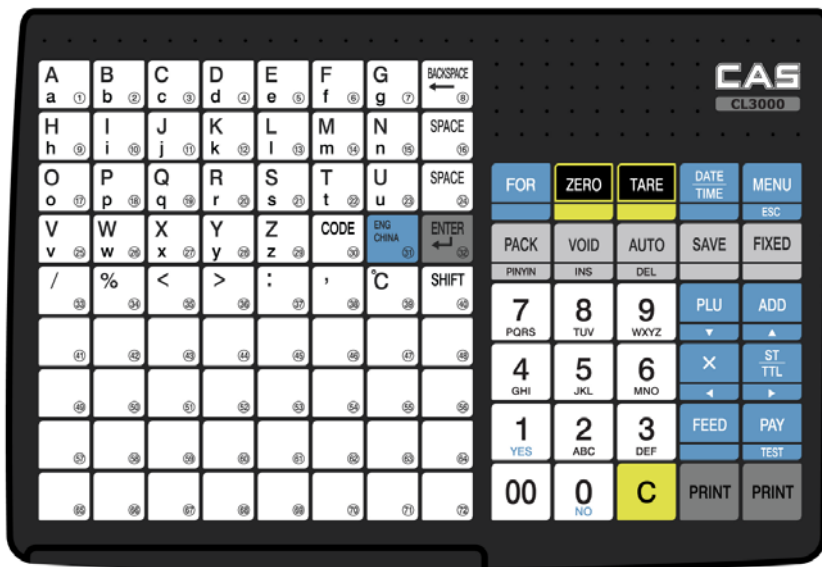











P – Type, R- Type (Pole type)













1.5 SYMBOLS

| SYMBOLS | DESCRIPTION |
|------------------|------------------------------------|
| ST (▼) | Stable weight indicator |
| ▶ 0 ◀ | Zero weight indicator |
| NET (▼) | Net weight indicator |
| AUTO | Auto Print Mode indicator |
| SAVE | Auto clearing status indicator |
| PREPACK | Prepack Mode indicator |
| DC (▼) | Discount status indicator |
| SHIFT (▼) | Speed key shift status indicator |
| TR | Data transmission status indicator |

1.6 KEY FUNCTIONS

| KEY | DESCRIPTION |
|---|---|
|  | Numeric keys. Used to enter pricing, qty, count, tare, etc. Used to enter chinese character in PINYIN mode. |
|  | Double zero key. |
|  | Clear key. Used to clear erroneous entries and error conditions. |
|  | Re-Zero key. Use to remove small variations in the scale's zero. |
|  | Tare key. Use to manually enter and remove tare weights. |
|  | Date & Time key. Toggles the display between time, date, scale number and department number. |
|  | MENU key. This key toggles from program menu to sale mode. Escape key. It is used to exit in program mode. |
|  | For key. Use this key for by- count or by pcs pricing: 3 @ 3 FOR \$1.00. It toggles between the QTY, PIECE, and PRICE fields. |
|  | AUTO key. Auto-print mode DELETE key. Used to delete text data in program mode. |
|  | Pre-Pack key. Used to enter Pre-Packaging mode in which the scale Auto-prints for every transaction and prevents the auto clearing of data. |
|  | Save key. Save mode prevents the auto clearing of any called-up data like tare weight, PLU pricing, etc. |
|  | FIXED key. Set a fixed price. |
|  | Void key. To remove erroneous sales from ADD-Up Insert key : Insert mode for text typing in program mode. |
|  | When you type a PLU number and press this key, it calls-up that PLU. |
|  | ADD-Up key. This key when used in conjunction with ST/TTL key allows you print a customer-total label as well as individual transaction labels. |

| KEY | DESCRIPTION |
|---|--|
|  | Multi-Label key. Use this key to print multiple sales of the same transaction. |
|  | Subtotal / Total key. Used with the ADD key in order to print customer-totals. |
|  | Feed key. Use this key to feed labels or paper through printer |
|  | Pay key. Use this key to calculate change. Test key. Used to print test pattern |
|  | Print key. Used to manually print transactions and also serves as an ENTER key. |
|  | Shift Key. Used to SHIFT function in program Mode |
|  | Alpha keys. Used to type text data. |
|  | Backspace key. Used to backspace and delete text data. |
|  | Space bar. |
|  | Used to go to next line to enter text |

Note: X key is only used in sale mode and ESC key is only used in program mode.

Sale mode : X key

Program mode : ESC key



1.7 Installation of the Label Roll

• Label Specifications

Outer diameter of roll : 100mm
Inner diameter of roll : 40mm
Width of receipt roll : 40, 50, 60mm
Width of label roll : 60mm(MAX)

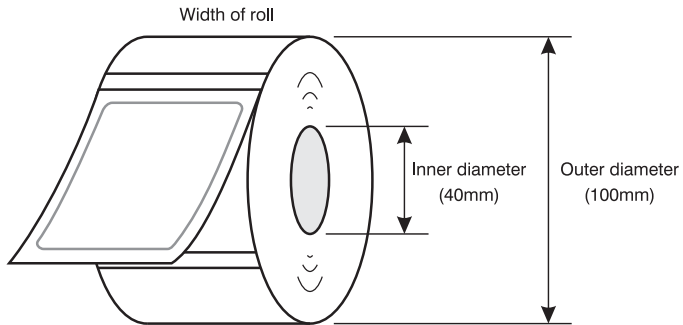

• Print Area

Width of label : 60mm(MAX)
Length of label : 120mm(MAX)

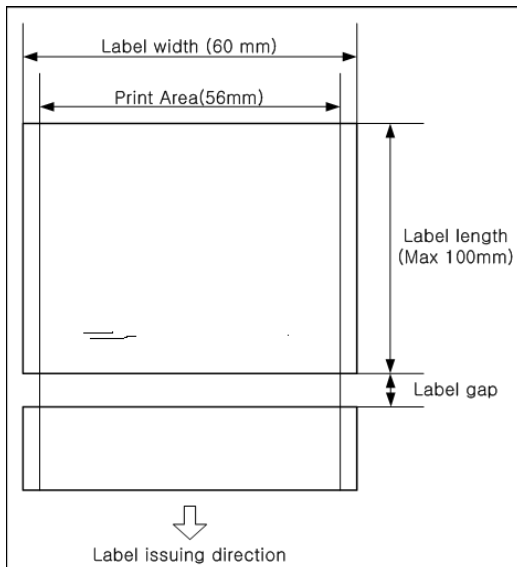

To install the label roll at ANY time you must follow the directions in this section:

1) Press the **ON/OFF** key and make sure that the display is completely off. Open the printer's side-access panel. (See fig.1)

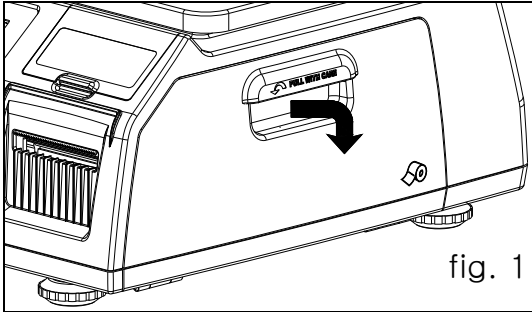

fig. 1

2) Lift up TPH lever as fig.2.

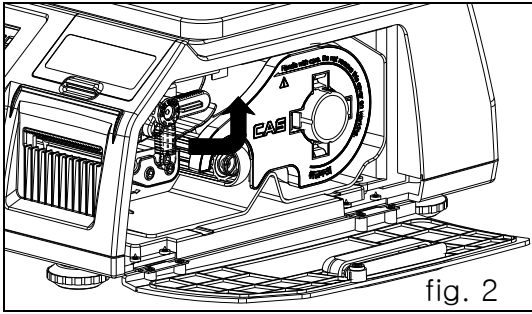

fig. 2

3) Remove cartridge as fig. 3.

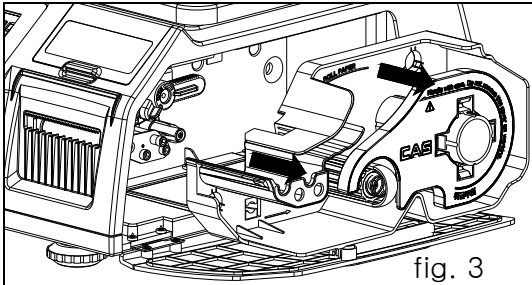
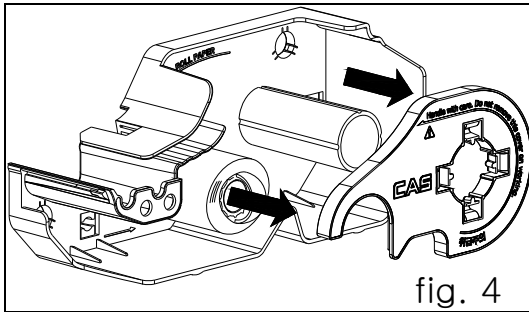
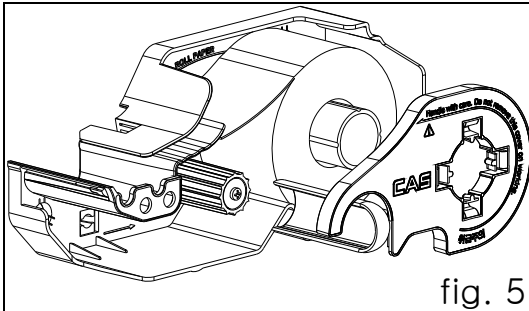

fig. 3

4) Remove Pick-Up Spool assembly and paper guide from the cartridge as fig. 4.



5) Place the label in the scale as fig. 5



6) Press the FEED key.

*If label position is not correct, you have to check follows :

- a. Label size.(Label setting menu)
- b. Feed Adjustment .(Feed adjustment menu)
- c. Sensor calibration(Sensor Calibration menu)

2. PROGRAMMING

Program Mode Menu Tree (Menu code : 1000)

| CODE | Menu | CODE | Sub Menu | CODE | Sub Menu | | | | |
|------|-------------------|------|-------------------|------|---------------------|------|--------------------|--|--|
| 1100 | PLU | 1110 | Change unit price | | | | | | |
| | | 1120 | New/Edit | | | | | | |
| | | 1130 | Discount | 1131 | New/Edit | | | | |
| | | | | 1132 | List | | | | |
| | | | | 1133 | Delete Discount | 1137 | Delete by PLU(DC) | | |
| | | | | | | 1138 | Delete by Dept(DC) | | |
| | | 1139 | Delete All(DC) | | | | | | |
| | | 1140 | Management | 1141 | Copy | | | | |
| | | | | 1142 | Delete | 1147 | Delete by PLU No | | |
| | | | | | | 1148 | Delete by Dept. No | | |
| | | | | | | 1149 | Delete All | | |
| | | | | 1143 | Move | | | | |
| | | | | 1144 | Select PLU Items | | | | |
| | | 1145 | PLU Sale Count | | | | | | |
| 1150 | List | | | | | | | | |
| 1160 | Speed Key | | | | | | | | |
| 1170 | Sample Printing | | | | | | | | |
| 1200 | PLU Data Table I | 1210 | Department | | | | | | |
| | | 1220 | Group | | | | | | |
| | | 1230 | Tax Rate | | | | | | |
| | | 1240 | Sales Message | | | | | | |
| | | 1250 | Origin | | | | | | |
| | | 1260 | Barcode | | | | | | |
| | | 1270 | Tare | | | | | | |
| | | 1280 | Unit Symbol | | | | | | |
| 1300 | PLU Data Table II | 1310 | Ingredient | | | | | | |
| | | 1320 | Nutrition Facts | | | | | | |
| 1400 | | 1410 | Store | | | | | | |
| | | 1420 | Customer | | | | | | |
| | | 1430 | Scroll Message | 1431 | Configuration | | | | |
| | | | | 1432 | Edit Scroll Message | | | | |
| | | | | 1433 | List Scroll Message | | | | |
| | | 1440 | Currency | | | | | | |
| 1500 | | 1510 | Label Format | | | | | | |
| | | 1520 | Barcode | | | | | | |
| | | 1530 | Discount | 1531 | Priority Setting | | | | |
| | | | | 1532 | Weight Discount | | | | |
| | | | | 1533 | Count Discount | | | | |
| | | | | 1534 | PCS Discount | | | | |
| | | 1540 | Tax | 1541 | Set Global Tax | | | | |
| | | | | 1542 | Global Tax No. | | | | |

| CODE | Menu | CODE | Sub Menu | CODE | Sub Menu |
|------|-------------------|------|--|------|--------------------|
| 1600 | Report | 1610 | X1 Report | 1611 | Scale |
| | | | | 1612 | PLU |
| | | | | 1613 | Misc. PLU |
| | | | | 1614 | Group |
| | | | | 1615 | Department |
| | | | | 1616 | Hourly |
| | | | | 1617 | Clerk |
| | | 1620 | Z1 Report | | |
| | | 1630 | X2 Report | 1631 | Scale |
| | | | | 1632 | PLU |
| | | | | 1633 | Misc. PLU |
| | | | | 1634 | Group |
| | | | | 1635 | Department |
| | | | | 1636 | Hourly |
| | | | | 1637 | Clerk |
| 1638 | Speed | | | | |
| 1640 | Z2 Report | | | | |
| 1650 | Clear All | | | | |
| 1700 | Scale Config | 1710 | Print Label Item | | |
| | | 1720 | Markdown | | |
| | | 1730 | Printer Hardware | 1731 | Print Mode |
| | | | | 1732 | Label/Ticket Size |
| | | | | 1733 | Sensor Calibration |
| | | | | 1734 | Sensor & Motor |
| | | | | 1735 | Print Intensity |
| | | | | 1736 | Adjust Feed Length |
| | | | | 1737 | Label Preprint |
| | | 1738 | Printer Speed | | |
| | | 1740 | Serial # Format | | |
| 1750 | Add-Up Total | | | | |
| 1760 | Ticket | 1761 | Select Ticket Item | | |
| | | 1762 | Select List Item | | |
| 1800 | Scale Config | 1810 | Sale Mode | | |
| | | 1820 | Operation Mode | | |
| | | 1830 | Department | | |
| | | 1840 | Date/Time | | |
| | | 1850 | User/ Security Configurati on | 1851 | New/Edit User |
| | | | | 1852 | Change Password |
| | | | | 1853 | List User |
| | | | | 1854 | Delete User |
| 1855 | Config Permission | | | | |
| 1856 | Clerk Key | | | | |

| CODE | Menu | CODE | Sub Menu | CODE | Sub Menu |
|------|---------------------|------|-------------------|------|--------------------|
| 1800 | Scale Config | 1860 | Test | 1861 | Display |
| | | | | 1862 | A/D |
| | | | | 1863 | Keyboard |
| | | | | 1864 | Chess Printer |
| | | | | 1865 | Printer Sensor |
| | | | | 1866 | Memory Information |
| | | | | 1867 | Firmware Version |
| | | 1870 | Scale Parameter | 1871 | Display |
| | | | | 1872 | Printing |
| | | | | 1873 | Sale setup |
| | | | | 1874 | Clerk Logout |
| 1880 | Function Key Define | | | | |
| 1900 | Communication | 1910 | Network Setting | 1911 | Service Type |
| | | | | 1912 | DHCP |
| | | | | 1913 | IP |
| | | | | 1914 | Remote IP |
| | | | | 1915 | RS232C |
| | | | | 1916 | WLAN setting |
| | | | | 1917 | WLAN Config |
| | | 1920 | Application | | |
| | | 1930 | Scale Lock/Unlock | | |
| | | 1940 | Check Scale | | |
| 1950 | Backup to Scale | | | | |

How to access PROGRAM MODE

You can see the Program Menu screen by pressing MENU key.

The 2 numbers at top left (1/9) indicate the number of pages or screens. The number to the left of the slash is the current page or screen number and the number to the right of the slash indicates the total number of pages or screens. You can use the PG UP and PG DOWN keys to navigate from page to page, or you can use the Arrow keys to go through each page 1 line at a time.



Menu code.

Selectable menu. If you want to select PLU, simply press 1.

If you press "PG DOWN" key, you can see other menu screens as below.

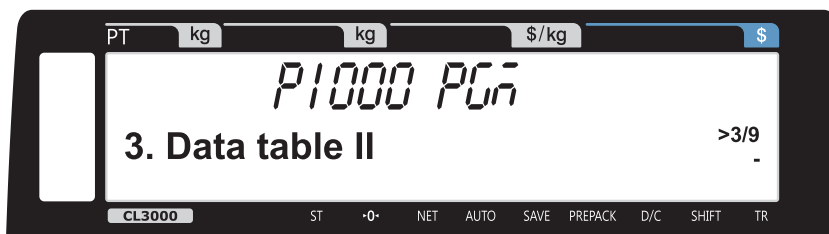
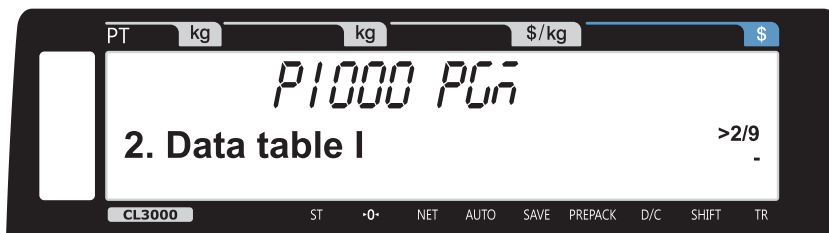

2.1 PLU Programming

You can set 32 items for a PLU as below table and if you do not want to use some items, you can prohibit those items in menu code:1144.

| No | Item | Description |
|----|------------------|---|
| 1 | Department | Department No. |
| 2 | PLU No | PLU No. |
| 3 | PLU Type | Select PLU type among By Weight, By Count or By-PCS |
| 4 | Name 1 | Enter name 1 of item. Maximum 40 characters. |
| 5 | Name 2 | Enter name 2 of item. Maximum 40 characters. |
| 6 | Name 3 | Enter name 3 of item. Maximum 40 characters. |
| 7 | Group No. | Select group number. This value can be from 0 to 99. |
| 8 | Ext.barcode | |
| 9 | Label No. | (0~99) (0=Do not use Label No.), Label Formats "1~12". If Global Setting is YES, it is not shown. |
| 10 | Aux. Label No. | (0~99) (0=Do not use Label No.), Label Formats "1~12". This function prints aux. label as saved number of label number |
| 11 | Origin No. | (0~500) 0=Do not use origin. |
| 12 | *Unit Weight | Unit weight of Price(No.19) (2:unit price for 100g, 1:unit price for 1kg) |
| 13 | *Fixed Weight | The weight is fixed regardless of item |
| 14 | Prefix | Enter serial code for PLU (Greece version of CL3000 series) |
| 15 | Item code | Item code |
| 16 | ☆Pieces | (0-999) Set the number for By-PCS PLU |
| 17 | Special Price | It can be unit price by using special key. |
| 18 | Tax No. | Enter tax number. This value can be from 0 to 9 |
| 19 | *Tare / Tare No. | You can enter tare weight manually or enter No. of tare data.(By-weight PLU) |
| 20 | | |
| 21 | Barcode No. | This value can be from 0 to 99, If Global setting is YES, it is not shown. |
| 22 | Barcode2 No. | This value can be from 0 to 99 |
| 23 | Picture No. | This value can be from 0 to 9 |

| No | Item | Description |
|----|-----------------|---|
| 24 | Produced Date | (0~999) This is subtracted to the current date in order to be calculated. |
| 25 | Packed Date | (0~999) This is added to the current date in order to be calculated. |
| 26 | Packed Time | (0~99) If you set it to 0, it is not printed |
| 27 | Sell Date | (0~9999) This is expirations date that is numbered in days and added to the Packed On date in order to be calculated. If you set it to 0, it is not printed |
| 28 | Sell Time | (0~99) If you set it to 0, it is not printed |
| 29 | Ingredients No. | (0~999) Enter ingredients |
| 30 | Safety No. | (0~99) Enter Safety No. |
| 31 | Nutri. Fact No. | (0~500) Enter nutrition fact ID |
| 32 | Sales Msg No. | (0~99) Enter sales message No. |

* These items are shown on the display when you select By Weight PLU.

☆ These items are shown on the display when you select By Count or By PCS PLU.

2.1.1 Create By-Weight PLU (Menu code 1120)

(NEW/Edit PLU : MENU → 1. PLU → 2. New/Edit)

- ◆ You can press the SAVE key at anytime to save the current PLU data and if you want to exit without saving, press the ESC key.

1. Enter Department No.

- Department should be set previously

M1120 PGM 01-32
Dept No. : [1] Default

2. Enter PLU No.

EX) Department No. = [1] Default
PLU No. : [1]

YES

M1120 PGM 02-32
PLU No. : [1] No Safety

3. Select PLU Type

1. By Weight →
2. By Count →
3. By PCS →

M1120 PGM 03-32
PLU Type : [1] By-Weight

EX) BY-Weight Item

By-Weight PLUs are priced as price-per-weight; for example, \$3.99/lb or \$1.99/kg. You must weigh these PLUs before you can execute a sales transaction. (#/△△ may be changed on Menu 1144).

4. Enter PLU Name 1

EX) “BEEF”

1
YES

B E E F
b e e f

M1120 PGM 04-32
Name 1: [BEEF]

5. Enter PLU Name 2

EX) “Sirloin”

S SHIFT I R L O I N
s i r l o i n

M1120 PGM 05-32
Name 2: [Sirloin]

6. Enter PLU Name 3

EX) “STEAK”

S T E A K
s t e a k

M1120 PGM 06-32
Name 3: [STEAK]

7. Select Group

- If there is no group for this PLU, enter 0.

EX) 1. Meat

1
YES

M1120 PGM 07-32
Group No.: [1] Meat

8. Enter Ext.Barcode

M1120 PGM 08-32
Ext.Barcode: []

9. Select Label Format

- If you enter “0”, standard label format (menu code 1510) is used.
- For details about label format, refer to 8. Setting Global option

EX) 1. IS6030-0000(60x30)

1
YES

M1120 PGM 10-32
Aux. Label No. : [1]

10. Select Origin

- If you do not want to use origin, enter “0”.

EX) 49. China

| | | |
|-----------------|------------------|-------|
| 4 GHI | 9 WXYZ | PRINT |
|-----------------|------------------|-------|

| | |
|--------------------|--------------|
| M1120 PGM | 10-32 |
| Origin No. : [49] | china |

11. Select Unit Weight

EX) 1.1kg

| | |
|-----------------|-------|
| 1 YES | PRINT |
|-----------------|-------|

| | |
|---------------------|--------------|
| M1120 PGM | 12-32 |
| Unit Weight : [1] | 1kg |

12. Enter Fixed Weight

The weight of an item is fixed.

- If you do not want to use, enter 0.

EX) Do not use Fixed Weight

| | |
|----------------|-------|
| 0 NO | PRINT |
|----------------|-------|

| | |
|------------------------|--------------|
| M1120 PGM | 13-32 |
| FixedWeight : [0.000] | |

13. Enter Prefix

- If you do not want to use, enter 0.

EX) Do not use Fixed Weight

| | |
|-----------------|-------|
| 1 YES | PRINT |
|-----------------|-------|

| | |
|------------------|--------------|
| M1120 PGM | 14-32 |
| Prefix : [1] | |

14. Item Code

EX) Item Code = 1941

| | | | | |
|-----------------|------------------|-----------------|-----------------|-------|
| 1 YES | 9 WXYZ | 4 GHI | 1 YES | PRINT |
|-----------------|------------------|-----------------|-----------------|-------|

| | |
|--------------------|--------------|
| M1120 PGM | 15-32 |
| ItemCode : [1941] | |

15. Price

EX) Price = \$10.00

| | | | | |
|-----------------|----------------|----------------|----------------|-------|
| 1 YES | 0 NO | 0 NO | 0 NO | PRINT |
|-----------------|----------------|----------------|----------------|-------|

| | |
|------------------|--------------|
| M1120 PGM | 16-32 |
| Price : [10.00] | |

16. Special Price

EX) Price = \$10.00

| | | | | |
|-----------------|----------------|----------------|----------------|-------|
| 2 ABC | 0 NO | 0 NO | 0 NO | PRINT |
|-----------------|----------------|----------------|----------------|-------|

| | |
|--------------------------|--------------|
| M1120 PGM | 17-32 |
| Special Price : [20.00] | |

17. Tax No.

- May be changed by setting Menu code 1541.
- If you do not want to use, enter “0” .

EX) Tax data 1

1 PRINT
YES

M1120 PGM **18-32**
Tax No. : [1]

18. Tare

- You can use Tare Table, depending on the setting of Parameter 584

EX) Tare Value = 100g

1 **0** **0** PRINT
YES NO NO

M1120 PGM **19-32**
Tare : [0.100] kg

19. Tare No.

- If you do not want to use, enter 0

EX) Tare No. = 1

1 PRINT
YES

M1120 PGM **20-32**
Tare No. : [1] 1.000kg

20. Barcode No.

- You can use barcode ID depending on the setting of Menu code 1520

EX) Barcode Data Table 1

1 PRINT
YES

M1120 PGM **21-32**
Barcode No. : [1]

21. Barcode2 No.

EX) EX) Barcode Data Table 1

1 PRINT
YES

M1120 PGM **22-32**
Barcode2 No. : [1]

22. Picture No.

- If you do not want to use, enter “0”

EX) Do not use Picture No.

0 PRINT
NO

M1120 PGM **23-32**
Picture No. : [0]

23. Produced Date

YES

| | |
|-----------------------|--------------|
| M1120 PGM | 24-32 |
| Produced Date : [1] | |

24. Packed Date

YES

| | |
|---------------------|--------------|
| M1120 PGM | 25-32 |
| Packed Date : [1] | |

25. Packed Time

YES

| | |
|---------------------|--------------|
| M1120 PGM | 26-32 |
| Packed Time : [1] | |

26. Sell By Date

- This value can be from 0 to 9999.
- If you do not want to use, enter “0”

EX) 2

ABC

| | |
|-------------------|--------------|
| M1120 PGM | 27-32 |
| Sell Date : [2] | |

27. Sell By Time

- This value can be from 0 to 99.
- If you do not want to use, enter “0”

EX) 10

YES
NO

| | |
|------------------|--------------|
| M1120 PGM | 28-32 |
| Sell Time : [10] | |

28. Ingredient No.

- If you do not want to use, enter “0”

EX) Do not use ingredient

NO

| | |
|------------------------|--------------|
| M1120 PGM | 29-32 |
| Ingredient No. : [0] | |

29. Safety No.

- If you do not want to use, enter “0”

1
YES PRINT

M1120 PGM **30-32**
Safety No. : [1]

30. Nutri. Fact No.

- If you do not want to use, enter “0”

1
YES PRINT

M1120 PGM **31-32**
Nutri.Fact No. : [1]

31. Sales Msg No.

- If you do not want to use, enter “0”

1
YES PRINT

M1120 PGM **32-32**
Sales Msg No. : [0] Thank You

EX) Sales Message 1

2.1.2 Create By-Count PLU (Menu code 1120)

(MENU → 1. PLU → 2. New/Edit)

- ◆ You can press the SAVE key at anytime to save the current PLU data and if you want to exit without saving, press the ESC key.

1. Enter Department No.

- Department should be set previously

1
YES PRINT

M1120 PGM **01-32**
Dept No. : [1] Default

EX) Department # = 1. Default

2. Enter PLU No.

EX) PLU # = 2

2
ABC PRINT

M1120 PGM **02-32**
PLU No. : [2] No Data or Param

3. Select PLU Type

1. By Weight →
2. By Count →
3. By PCS →

EX) BY-Count Item

2
ABC PRINT

M1120 PGM **03-32**
PLU Type : [2] By-Count

4. Enter PLU Name 1

EX) "PEAR"

P **E** **A** **R** PRINT
p [Ⓡ] e [Ⓢ] a [Ⓣ] r [Ⓡ]

M1120 PGM **04-29**
Name1:[PEAR]

5. Qty Unit No.

EX) Qty Unit No. 6

6 PRINT
MNO

M1120 PGM **14-29**
Qty Unit No. : [6]

6. Price

EX) Price = \$10.00

1 **0** **0** **0** PRINT
YES NO NO NO

M1120 PGM **15-29**
Price : [10.00]

2.1.3 Create By-PCS PLU (Menu code 1120)

(MENU → 1. PLU → 2. New/Edit)

※ By-PCS PLU is used depending on the Para 593.

◆ You can press the SAVE key at anytime to save the current PLU data and if you want to exit without saving, press the ESC key.

1. Enter Department No. / PLU No.

- Department should be set previously

EX) Department # = 1. Default

1 PRINT
YES

M1120 PGM **01-32**
Dept No. : [1] Default

2. Enter PLU No.

EX) PLU # =3

| | |
|-----------------|-------|
| 3 DEF | PRINT |
|-----------------|-------|

| | |
|------------------|------------------|
| M1120 PGM | 02-32 |
| PLU No. : [3] | No Data or Param |

3. Select PLU Type

1. By Weight →
2. By Count →
3. By PCS →

EX) BY-PCS Item

| | |
|-----------------|-------|
| 3 DEF | PRINT |
|-----------------|-------|

| | |
|------------------|--------------|
| M1120 PGM | 03-32 |
| PLU Type : [3] | By-PCS |

4. Enter PLU Name1

EX) "CAKE"

| | | | | |
|-----------------|-----------------|-----------------|-----------------|-------|
| C c Ⓢ | A a Ⓡ | K k Ⓣ | E e Ⓢ | PRINT |
|-----------------|-----------------|-----------------|-----------------|-------|

| | |
|------------------|--------------|
| M1120 PGM | 04-30 |
| Name1:[CAKE |] |

5. Pieces

- If you enter "0", it is regarded as 1.

EX) 10 piece

| | | |
|-----------------|----------------|-------|
| 1 YES | 0 NO | PRINT |
|-----------------|----------------|-------|

| | |
|------------------|--------------|
| M1120 PGM | 16-30 |
| Pieces : [10] | |

6. Qty Unit No.

EX) Qty Unit No. 6

| | |
|-----------------|-------|
| 6 MNO | PRINT |
|-----------------|-------|

| | |
|---------------------|--------------|
| M1120 PGM | 17-30 |
| Qty Unit No. : [6] | |

2.1.4 Editing PLU (Menu code 1120)

(MENU → 1. PLU → 2. New/Edit)

- ◆ You can edit PLU as PLU creating and you can press the SAVE key at anytime to save the current PLU data and if you want to exit without saving, press the ESC key.

2.1.5 Sample Printing (Menu code 1170)

(MENU → 1. PLU → 7. Sample Printing)

- If you press SAVE key during PLU creating or editing, label is printed.

2.1.6 Listing PLU (Menu code 1150)

(MENU → 1. PLU → 5. List)

1. Enter Department No.

- Enter department number that you wish to see

| | |
|-----|-------|
| 1 | PRINT |
| YES | |

EX) Department No. 1

| | |
|------------------|--------------|
| P1150 PGM | 01-03 |
| Dept No.: [1] | Default |

2. Enter PLU Range

EX) PLU 1~999999

- If you want to print PLU list, press the TEST key.

| | | | | |
|-----|-------|-----|----|-------|
| 1 | PRINT | 1 | 0 | PRINT |
| YES | | YES | NO | |

| | |
|--------------------|--------------|
| P1150 PGM | 02-03 |
| Start PLU No: [1] | |

| | |
|------------------------|--------------|
| P1150 PGM | 03-03 |
| End PLU No : [999999] | |

| | |
|------------------|--------------|
| P1150 PGM | 03-03 |
| 1 1 BEEF | NO 00003 |

2.1.7 Copying PLU (Menu code 1141)

(MENU → 1. PLU → 4. Management → 1. Copy)

- If there is a similar PLU, you can copy it.

1. Select Source Department No.

- Enter the Department No. that you wish to copy

| | |
|-----|-------|
| 1 | PRINT |
| YES | |

EX) Source Department # = 1

| | |
|------------------------|--------------|
| P1141 PGM | 01-04 |
| Source Dept. No.: [1] | Grocery |

2. Select Source PLU No.

- Enter the PLU No. that you wish to copy

EX) Source PLU # =1

1
YES PRINT

P1141 PGM **02-04**
Source PLU No. : [1] Potato

3. Select Destination Department No.

- Enter the Department number where the new PLU(s) will be located

EX) Destination Department # =2

2
ABC PRINT

P1141 PGM **03-04**
Dest. Dept. No. : [2] vegetable

4. Select Destination PLU No.

- Enter the PLU number that you wish to copy the Source PLU into

EX) Destination PLU # =1

1
YES PRINT

P1141 PGM **04-04**
Dest. PLU No. : [1] No Data

2.1.8 Deleting PLU (Menu code 1142)

(MENU → 1. PLU → 4. Management → 2. Delete)

- There are three ways to delete PLU. Simply enter the number that you wish to delete.

EX) Press 1 key to select Delete by PLU No.

1
YES PRINT

P1142 PGM **04-04**
1. Delete by PLU No. >1/3

EX) Department No. : 1

1
YES PRINT

P1147 PGM **01-02**
Department No. : [1] Grocery

EX) PLU No. : 1

1
YES PRINT

P1147 PGM **02-02**
PLU No. : [1]

2.1.9 Moving PLU (Menu code 1143)

(MENU → 1. PLU → 4. Management → 3. Move)

- You can move PLU. If there is discount information, it is also moved.

1. Select Source

- Enter the Department No. and PLU No. which you wish to move

EX) Source Department # = 1
Source PLU # = 1

1
YES PRINT

P1143 PGM

01-04

Source Dept. No. : [1]

Grocery

1
YES PRINT

P1143 PGM

02-04

Source PLU No. : [1]

Potato

2. Select Destination

- Enter the Department number where the PLU(s) will be located
- Enter the PLU number that you wish to move the Source PLU into

2
ABC PRINT

P1143 PGM

03-04

Dest. Dept. No. : [2]

vegetable

1
YES PRINT

P1143 PGM

04-04

Dest. PLU No. : [1]

No Data

2.1.10 Selecting PLU Items (Menu code 1144)

(MENU → 1. PLU → 4. Management → 4. Select PLU items

- If you enter Y, you cannot use that item when you create PLU.
- To enter Y, press Y key or 1 key.
- To enter N, press N key or 0 key.

| | |
|------------------|--------------|
| P1144 PGM | 01-23 |
| Name2 : [N] | |

| | |
|------------------|--------------|
| P1144 PGM | 02-23 |
| Name3 : [Y] | |

Note: You can use the "PG UP" and "PG DOWN" keys to navigate from page to page, or you can use the Arrow keys to go through each page 1 line at a time.

2.1.11 PLU Sale Count (Menu code 1145)

(MENU → 1. PLU → 4. Management → 5. PLU Sale Count

You can count each PLU sale and also you can clear this count.

- This sale count is used for serial number printing of PLU

| | |
|----------|--------------|
| 1 | PRINT |
| YES | |

| | |
|------------------------|--------------|
| P1145 PGM | 01-03 |
| Department No. : [1] | Grocery |

| | |
|----------|--------------|
| 1 | PRINT |
| YES | |

| | |
|------------------|--------------|
| P1145 PGM | 02-03 |
| PLU No. : [1] | |

- To clear PLU sale count, press the TEST key

| | |
|-----------------------|--------------|
| P1145 PGM | 03-03 |
| [TEST]= clear [Z]=res | CN:20 |

2.2 Programming PLU Data Table I

2.2.1 Department (Menu code 1210)

(MENU → 2. PLU Data Table I → 1. Department)

If a scale is assigned to department 1 then all of the PLUs that you select on that scale will be from department 1. You can assign the department by pressing MENU, 8 and 3 keys. If you want to change the department assignment of the scale, you have to change the setting. You also have to set Speed key for this department.

2.2.2 New/Edit Department (Menu code 1211)

(MENU → 2. PLU Data Table I → 1. Department → 1. New/Edit)

- ◆ You can press the SAVE key at anytime to save the current data and if you want to exit without saving, press the ESC key.

1. Department Number

- Department number is available 1 to 99.

EX) Department No. = 2

2
ABC PRINT

P1211 PGM 01-03
Dept No. : [2]

2. Department Description

EX) Department Description = GROCERY

G R O C E R Y PRINT
g r o c e r y

P1211 PGM 02-03
Description:[GROCERY]

3. Speed Key Setting

- Refer to 2.6.1 Speed Key

EX) Speed key set no. = 1

1
YES PRINT

P1211 PGM 03-03
Speed Key Set No: [1]

2.2.3 List Department (Menu code 1212)

(MENU → 2. PLU Data Table I → 1. Department → 2. List)

1. Set the department range that you wish to see.

EX) Department 1 to 99

- If you want to print list, press the TEST key.



P1212 PGM **01-02**
1St Number: [1]

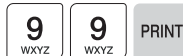

P1212 PGM **02-02**
2nd Number : [99]

P1212 PGM **02-02**
1 1 Default

2.2.4 Delete Department (Menu code 1213)

(MENU → 2. PLU Data Table I → 1. Department → 2. Delete)

1. Enter Department number

EX) Delete department 2



P1213 PGM **01-01**
Dept No. : [2] **GROCERY**

2.2.5 Group (Menu code 1220)

(MENU → 2. PLU Data Table I → 2. Group)

This menu is to group any PLU(s) regardless the PLU's "department". Any individual PLU must be involved in any department, but not in any group. User may select any PLUs as a group at users' needs. Especially, grouping PLU(s) can be used to get total sum for a specific.

2.2.6 New/Edit Group (Menu code 1221)

(MENU → 2. PLU Data Table I → 1. Group → 1. New/Edit)

You can press the SAVE key at anytime to save the current data and if you want to exit without saving, press the ESC key.

1. Enter Group Number

- Group number is available 1 to 99.

EX) Group No = 1

1
YES PRINT

P1221 PGM

01-02

Group No. : [1]

2. Enter Group Description

EX) Group Description = BAGEL

B A G E L PRINT
b ② a ① g ⑦ e ⑤ l ③

P1221 PGM

02-02

Description : [BAGEL]

2.2.7 List Group (Menu code 1222)

(MENU → 2. PLU Data Table I → 2. Group → 2. List)

1. Set the group range that you wish to see

EX) 1~99

- If you want to print list, press the TEST key.

1
YES PRINT

P1222 PGM

01-02

1st Number: [1]

9 9 PRINT
WXYZ WXYZ

P1222 PGM

02-02

2nd Number : [99]

P1222 PGM

02-02

1 BAGEL

2.2.8 Delete Group (Menu code 1223)

(MENU → 2. PLU Data Table I → 2. Group → 3. Delete)

1. Enter group number

EX) Delete group 1.

1
YES PRINT

P1222 PGM 01-01
Group No : [1] BAGEL

2.2.9 Tax Rate (Menu code 1230)

(MENU → 2. PLU Data Table I → 3. TAX Rate)

You can use tax number when you create PLU.

2.2.10 New/Edit Tax Rate (Menu code 1231)

(MENU → 2. PLU Data Table I → 3. TAX Rate → 1. New/Edit)

- ◆ You can press the SAVE key at anytime to save the current data and if you want to exit without saving, press the ESC key.

1. Enter tax number

- TAX number is available 1 to 9

EX) TAX No. = 1

1
YES PRINT

P1231 PGM 01-03
TAX No. : [1]

2. Set Tax Type

- See Tax Type table as below.

EX) Internal TAX Type

0
NO PRINT

P1231 PGM 02-03
TAX TYPE: [0] INTERNAL

Tax Type

| Item | Symbol | Description |
|--------------|--------|--------------------------------|
| Internal TAX | 0 | Tax is included in total price |
| External TAX | 1 | Tax is added on total price |

※ Refer to menu code 1873(T.price = price + Tax) on chapter 2.14.21

3. Enter Tax Rate

EX) Tax Rate = 5.00%



4. Exit Menu

- If you want to exit, press “ESC” key.



2.2.11 List Tax Rate (Menu code 1232)

(MENU → 2. PLU Data Table I → 3. TAX Rate → 2. List)

3. Set the range of tax rate

EX) 1~9

- If you want to print list, press the TEST key.

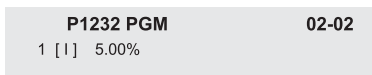
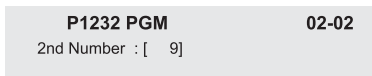
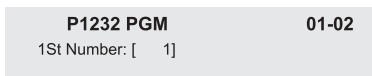

2.2.12 Delete Tax Rate (Menu code 1233)

(MENU → 2. PLU Data Table I → 3. TAX Rate → 3. Delete)

1. Enter tax number

EX) Delete tax number 1

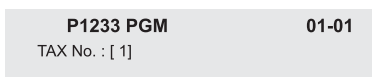

2.2.13 Sales Message (Menu code 1240)

(MENU → 2. PLU Data Table I → 4. Sales Message)

Sales message can be printed on PLU labels so long as the format that you use contains a Sales Message field. This is a great tool for advertising and cross-marketing products.

2.2.14 New/Edit Sales Message (Menu code 1241)

(MENU → 2. PLU Data Table I → 4. Sales Message → 1. New/Edit)

- ◆ You can press the SAVE key at anytime to save the current data and if you want to exit without saving, press the ESC key.

1. Enter Message Number

- Message number is available 1 to 99



EX) Message No. = 1



2. Enter Message

EX) Message = THANK YOU

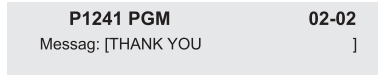

3. Exit Menu

- If you want to exit, press “ESC” key.



2.2.15 List Sales Message (Menu code 1242)

(MENU → 2. PLU Data Table I → 4. Sales Message → 2. List)

1. Set the List Range

- Set the range of sales message that you wish to check



EX) 1~99



- If you want to print list, press the TEST key.



P1242 PGM 02-02
2nd Number : [99]

P1242 PGM 02-02
1 THANK YOU

2.2.16 Delete Sales Message (Menu code 1243)

(MENU → 2. PLU Data Table I → 4. Sales Message → 3. Delete)

1. Enter Message No.

EX) Delete message 1.



P1243 PGM 01-01
Sales Msg No. : [1]

2.2.17 Origin (Menu code 1250)

(MENU → 2. PLU Data Table I → 5. Origin)

You can use origin number when you create PLU.

How to print origin on a label

1. The format that you use contains Origin field
2. Set MENU → 8. scale config → 6. parameter → 2. printing oper(print origin for comm.Line)

2.2.18 New/Edit Origin (Menu code 1251)

(MENU → 2. PLU Data Table I → 5. Origin → 1. New/Edit)

- ◆ You can press the SAVE key at anytime to save the current data and if you want to exit without saving, press the ESC key.

1. Enter Origin No.

- Origin number is available 1 to 500

EX) Origin No = 10

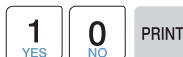

P1251 PGM 01-02
Origin No. [10]

2. Enter Origin

EX) Origin = KOREA



3. Exit Menu

• If you want to exit, press “ESC” key.



2.2.19 List Origin (Menu code 1252)

(MENU → 2. PLU Data Table I → 5. Origin → 2. List)

1. Set the List Range

• Set the range of origin that you wish to check

EX) 1~500

• If you want to print list, press the TEST key.



2.2.20 Delete Origin (Menu code 1253)

(MENU → 2. PLU Data Table I → 5. Origin → 3. Delete)

1. Enter Origin No.

EX) Delete Origin 10.

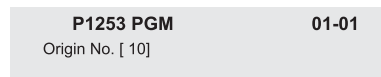

2.2.21 Barcode (Menu code 1260)

(MENU → 2. PLU Data Table I → 6. Barcode)

You can use barcode when you create PLU.

Barcode can be changed depending on the Global setting of barcode.

2.2.22 New/Edit Barcode (Menu code 1261)

(MENU → 2. PLU Data Table I → 6. Barcode → 1. New/Edit)

1. Enter Barcode No.

- This value can be from 1 to 99.

1
YES PRINT

EX) Barcode No = 1

P1261 PGM **01-05**
Barcode No : [1]

2. Barcode Description

EX) Barcode Description = EAN13

E **A** **N** **1** **3** PRINT
e ⑤ a ① n ⑩ YES DEF

P1261 PGM **02-05**
Description:[EAN13]

3. Barcode Type

- See below table.

EX) Barcode Type = 1. EAN

1 PRINT
YES

P1261 PGM **03-05**
Type : [1] EAN-13

► Type of Barcode

| No. | Type | Description |
|-----|---------|---|
| 1 | EAN-13 | 13digit |
| 2 | EAN13A5 | 13digit + 5digit |
| 3 | EAN-8 | 8 digit |
| 4 | I20F5 | 2~24 digit |
| 5 | UPCA | 12 digit |
| 6 | UPC-13 | 13 digit |
| 7 | CODE39 | Alphanumeric character, Format 'T', prints out the name of PLU. |
| 8 | CODE93 | |
| 9 | CODE128 | |
| 10 | CODABAR | |

4. Enter Barcode Form

You can select from a list of Barcode types or you can create your own custom format

- Refer to below table.

EX) Barcode Form = 1.

Change DDIIIIIPPPPPC to GGIIIIIVPPPPC

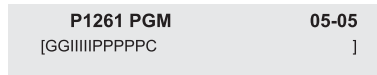
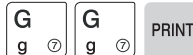
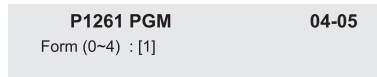

► The following defines the format characters for Barcode Formats : (Example 'EAN13')

| Form No. | Format |
|----------|----------------------|
| 0 | User Defined Barcode |
| 1 | DDIIIIIPPPPPC |
| 2 | DDIIIIIPPPPPC |
| 3 | DIIIIIIPPPPPC |
| 4 | DIIIIIIPPPPPC |

► The following defines the format characters for Barcode Formats: (Example)

| No. | Symbol | Description |
|-----|--------|---|
| 1 | I | item code |
| 2 | N | PLU number |
| 3 | P | price |
| 4 | V | price check digit (It is created automatically) |
| 5 | U | unit price |
| 6 | W | weight |
| 7 | Q | quantity |
| 8 | D | department |
| 9 | G | group |
| 10 | K | country code (For future) |
| 11 | A | ticket counter (Only for ticket) |
| 12 | B | scale transaction counter |
| 13 | C | total barcode check sum (It is created automatically) |
| 14 | F | PLU prefix character |
| 15 | T | text character |
| 16 | R | transaction counter for each PLU |
| 17 | L | clerk number |
| 18 | X | traceability number |
| 19 | Y | slaughter house number |
| 20 | Z | cutting hall number |
| 21 | E | born in country number |
| 22 | H | bred in country number |
| 23 | M | bar string |
| 24 | % | %; print next fixed character* |
| 25 | 0~9 | numbers |

※ %: It is used to enter characters therefore you cannot use this to enter numbers.

5. Exit Menu

- If you want to exit, press “ESC” key.



2.2.23 List Barcode (Menu code 1262)

(MENU → 2. PLU Data Table I → 6. Barcode → 1. List)

1. Set the list range

- Set the range of barcode that you wish to check

EX) 1~10

- If you want to print list, press the TEST key.



P1262 PGM **01-02**

1St Number: [1]

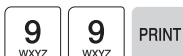

P1262 PGM **02-02**

2nd Number : [99]

P1262 PGM **02-02**

1 1 GGIIIIIIPPPPC

2.2.24 Delete Barcode (Menu code 1263)

(MENU → 2. PLU Data Table I → 6. Barcode → 3. Delete)

1. Enter barcode number to delete

EX) Delete barcode 1.



P1263 PGM **01-01**

Barcode No : [1]

2.2.25 Tare (Menu code 1270)

(MENU → 2. PLU Data Table I → 7. Tare)

If Parameter 584 option (Use Tare No.) is "Yes" you can use this tare number which is set here when you create PLU, If it is set to "No" you have to program tare weight again.

2.2.26 New/Edit Tare (Menu code 1271)

(MENU → 2. PLU Data Table I → 7. Tare → 1. New/Edit)

- ◆ You can press the SAVE key at anytime to save the current data and if you want to exit without saving, press the ESC key.

1. Enter Tare No.

- This value can be from 1 to 99.

1 PRINT
YES

EX) Tare No. = 1

P1271 PGM 01-04
Tare No. : [1]

2. Tare Description

EX) Tare Description = Container

C O N T A
c ③ o ⑰ n ⑱ t ⑳ a ①
I N E R PRINT
i ⑩ n ⑲ e ④ r ㉑

P1271 PGM 02-04
Description : [CONTAINER]

3. Tare Type

- There are 2 types as below table

1 PRINT
YES

EX) Tare Type = 1, Numeric Tare

P1271 PGM 03-04
Tare Type : [1] Numeric

If you set Tare Type to "2", put a container on the platter and press the PRINT key after 2~3 seconds.

► Type of Tare

| Tare No. | Type of Tare | Description |
|----------|--------------|--|
| 1 | Numeric Tare | Enter tare weight by using numeric keys. |
| 2 | Weight Tare | Put a container on the platter |

4. Enter Tare Value

EX) Tare = 0.010 kg

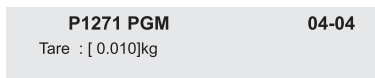
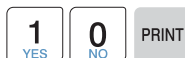

5. Exit Menu

• If you want to exit, press “ESC” key.



※ If you set Tare No. to 1 when you create PLU, tare is set to 0.010kg that is programmed here.

2.2.27 List Tare (Menu code 1272)

(MENU → 2. PLU Data Table I → 7. Tare → 2. List)

1. Set the list range

- Set the range of barcode that you wish to check

EX) 1~10

• If you want to print list, press the TEST key.

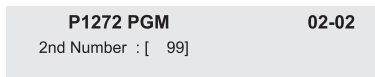
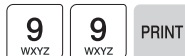

2.2.28 Delete Tare (Menu code 1273)

(MENU → 2. PLU Data Table I → 7. Tare → 3. Delete)

1. Enter tare number to delete

EX) Delete tare no. 1

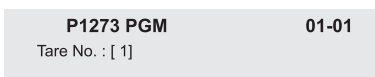

2.2.29 Tare Key (Menu code 1274)

(MENU → 2. PLU Data Table I → 7. Tare → 4. Tare Key)

You can assign Tare Key. There are 9 Tare keys and you have to set these keys in menu 1880 (Key define). See Chapter 2.14.22

1. Enter tare Key

EX) Tare Key = 1



2. Enter tare number

EX) Tare No = 1



2.2.30 Unit Symbol (Menu code 1280)

(MENU → 2. PLU Data Table I → 8. Unit Symbol)

You can program the unit symbol to print label.

2.2.31 New/Edit Unit Symbol (Menu code 1281)

(MENU → 2. PLU Data Table I → 8. Unit Symbol → 1. New/Edit)

※ You can press the SAVE key at anytime to save the current data and if you want to exit without saving, press the ESC key.

1. Enter unit number

- This value can be from 1 to 8.

EX) Qty Unit No. = 1



2. Enter unit symbol

EX) Symbol = ™

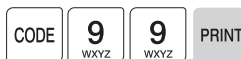

※ If you want to enter special symbol, press the CHAR key and enter the code value.
(See ASCII code table on chapter 4.4)

3. Exit Menu



• If you want to exit, press “ESC” key.

2.2.32 List Unit Symbol (Menu code 1282)

(MENU → 2. PLU Data Table I → 8. Unit Symbol → 2. List)

1. Set the list range

EX) 1~8

• If you want to print list, press the TEST key.

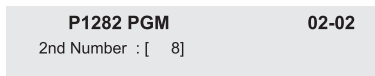

2.2.33 Delete Unit Symbol (Menu code 1283)

(MENU → 2. PLU Data Table I → 8. Unit Symbol → 3. Delete)

1. Enter unit symbol number to delete

EX) Delete unit symbol 1.



2.3 Programming PLU Data Table II

2.3.1 Ingredient (Menu code 1310)

(MENU → 3. PLU Data Table II → 1. Ingredient)

2.3.2 New/Edit Ingredient (Menu code 1311)

(MENU → 3. PLU Data Table II → 1. Ingredient → 1. New/Edit)

- ◆ You can press the SAVE key at anytime to save the current data and if you want to exit without saving, press the ESC key.

1. Enter ingredient number.

- This value can be from 1 to 1999.



EX) Ingredient number = 1



2. Enter ingredient

EX) Ingredient Line1 = SALT
Ingredient Line 2 = SUGAR



- To print "SUGAR" on next line, enter "↵" after "SALT".
- The number of right side of "[]" is digit and total number of character.
- Pressing "PAGE UP/DN" key turns to next or previous page.

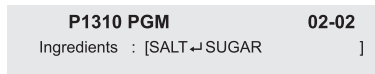

3. Exit Menu

- If you want to exit, press "ESC" key.



2.3.3 List Ingredient (Menu code 1312)

(MENU → 3. PLU Data Table II → 1. Ingredient → 2. List)

1. Set the list range

EX) 1~1999

- If you want to print list, press the TEST key.

1
YES PRINT

P1312 PGM **01-02**

1st Number: [1]

1 **9** **9** **9** PRINT
YES WXYZ WXYZ WXYZ

P1312 PGM **02-02**

2nd Number : [1999]

P1312 PGM **02-02**

1 SALT ↔ SUGAR

2.3.4 Delete Ingredient (Menu code 1313)

(MENU → 3. PLU Data Table II → 1. Ingredient → 3. Delete)

1. Enter ingredient number to delete

EX) Delete ingredient no. 1

1
YES PRINT

P1313 PGM **01-01**

Ingredient No. : [1]

2.3.5 Nutrition Facts (Menu code 1320)

(MENU → 3. PLU Data Table II → 2. Nutrition Facts)

- ◆ You can program nutrition facts for your needs and you can use this when you create PLU. Nutrition facts is printed small or large size depending on the label format.

► Nutrition Facts table

| Nutrition Facts | Description |
|---------------------|-------------|
| Calories | |
| Calories From Fat | |
| Total Fat | G |
| Saturated Fat | G |
| Cholesterol | mg |
| Sodium | mg |
| Total Carbohydrates | G |
| Dietary Fibers | G |
| Sugars | G |
| Protein | G |
| Vitamin A | % |
| Calcium | % |
| Vitamin C | % |
| Iron | % |
| Etc | |

2.3.6 New/Edit Nutrition Facts (Menu code 1321)

(MENU → 3. PLU Data Table II → 2. Nutrition Facts → 1. New/Edit)

- ◆ You can press the SAVE key at anytime to save the current data and if you want to exit without saving, press the ESC key.
You can use the PG UP and PG DOWN keys to navigate from page to page, or you can use the Arrow keys to go through each page 1 line at a time..

1. Nutrition Fact No

- This value can be from 1 to 500.

1 PRINT

EX) Nutrition fact no = 1

P1321 PGM 01-19
Nutrition Fact No. : [1]

2. Enter description

EX) BEEF STEW

B E E F S
b e e f s

T E W PRINT
t e w

P1321 PGM 02-19
Description : [BEEFSTEW]

3. Enter Serving Size

EX) Sering size = 1CUP

| | | | | |
|----------|----------|----------|----------|-------|
| 1 YES | C c ① | U u ② | P p ③ | PRINT |
|----------|----------|----------|----------|-------|

| | |
|----------------------|--------------|
| P1321 PGM | 03-19 |
| Serving Size : [1CUP |] |

4. Serving Per Container

EX) Sering Per Container = 2

| | |
|----------|-------|
| 2 ABC | PRINT |
|----------|-------|

| | |
|----------------------|--------------|
| P1321 PGM | 04-19 |
| Serving Per Con : [2 |] |

5. Calories

EX) Calories = 230

| | | | |
|----------|----------|---------|-------|
| 2 ABC | 3 DEF | 0 NO | PRINT |
|----------|----------|---------|-------|

| | |
|------------------|--------------|
| P1321 PGM | 05-19 |
| Calories | : [230] |

6. Calories from fat

EX) Calories From Fat= 120

| | | | |
|----------|----------|---------|-------|
| 1 YES | 2 ABC | 0 NO | PRINT |
|----------|----------|---------|-------|

| | |
|----------------------------|--------------|
| P1321 PGM | 06-19 |
| Calories From Fat: [120] | |

7. Total Fat

EX) Total fat = 14 g

| | | |
|----------|----------|-------|
| 1 YES | 4 GHI | PRINT |
|----------|----------|-------|

| | |
|--------------------------|--------------|
| P1321 PGM | 07-19 |
| Total Fat (g) : [14] g | |

8. Saturated fat

EX) Saturated fat = 7 g

| | |
|-----------|-------|
| 7 PQRS | PRINT |
|-----------|-------|

| | |
|-----------------------|--------------|
| P1321 PGM | 08-19 |
| Saturated Fat : [7] | |

9. Trans fat

EX) Trans fat = 2

| | |
|----------|-------|
| 2 ABC | PRINT |
|----------|-------|

| | |
|-----------------------|--------------|
| P1321 PGM | 09-19 |
| Trans Fat (g) : [2] | |

10. Cholesterol

EX) Cholesterol = 40 mg

GHI NO

P1321 PGM **10-19**
Cholesterol (mg) : [40]

11. Sodium

EX) Sodium = 950 mg

WXYZ JKL NO

P1321 PGM **11-19**
Sodium (mg) : [950]

12. Total Carbohydrate

EX) Total Carbohydrate = 16 g

YES MNO

P1321 PGM **12-19**
Total Carbohydrate : [16] g

13. Dietary Fibers

EX) Dietary Fiber = 2 g

ABC

P1321 PGM **13-19**
Dietary Fibers : [2] g

14. Sugars

EX) Sugars = 3 g

DEF

P1321 PGM **14-19**
Sugars (g) : [3]

15. Protein

EX) Protein = 11 g

YES YES

P1321 PGM **15-19**
Protein (g) : [11]

16. Vitamin A

EX) Vitamin A = 20%

ABC NO

P1321 PGM **16-19**
Vitamin A (%) : [20]

17. Calcium

EX) Calcium = 2%



18. Vitamin C

EX) Vitamin C = 0 %



19. Iron

EX) Iron = 6 %



20. Exit Menu



- If you want to exit, press “ESC” key.

2.3.7 List Nutrition Facts (Menu code 1322)

(MENU → 3. PLU Data Table II → 2. Nutrition Facts → 2. List)

1. Set the list range

EX) 1~500

- If you want to print list, press the TEST key.



2.3.8 Delete Nutrition Facts (Menu code 1323)

(MENU → 3. PLU Data Table II → 2. Nutrition Facts → 3. Delete)

1. Enter nutrition fact number to delete.

EX) Delete nutrition facts no.1

1
YES PRINT

P1312 PGM **01-01**
Nutrition Facts No : [1]

2.4 Discount Programming

2.4.1 Discount (Menu code 1130)

(MENU → 1. PLU → 3. Discount)

You have to set discount information for each PLU.

2.4.2 New/Edit Discount (Menu code 1131)

(MENU → 1. PLU → 3. Discount → 1. New/Edit)

- ◆ You can press the SAVE key at anytime to save the current data and if you want to exit without saving, press the ESC key.
You can use the PG UP and PG DOWN keys to navigate from page to page, or you can use the Arrow keys to go through each page 1 line at a time.

1. Enter department number

EX) Department No = 1

1
YES PRINT

P1131 PGM **01-12**
Department No. : [1] Default

2. Enter PLU number.

EX) PLU No = 1

1
YES PRINT

P1131 PGM **02-12**
PLU No. : [1] BEEF

3. Enter discount type

- Refer to Discount Type table as below



- ※ Discount information can be different depending on the discount type.

P1131 PGM **03-12**
Discount Type : [1] U Price

EX) 1. Unit Price Discount

► Discount Type

| # | Type | Description |
|----|------------------------------|--|
| 1 | Unit Price Discount | - By Weight PLU: Set the discount amount on unit price, depending on weight. - By Count/PCS PLU: Set the discount amount on unit price, depending on number of items. |
| 2 | % Unit Price Discount | - By Weight PLU: set discount % of unit price, depending on weight. - By Count/PCS PLU: set discount % of unit price, depending on number of items. |
| 3 | Total Price Discount | - Set discount amount for total price. |
| 4 | % Total Price Discount | - Set discount % of total price. |
| 5 | Fixed Price | - Set a fixed amount for discount. |
| 6 | Free Item | - Set free of charge item. |
| 7 | Free Addition | - By Weight PLU: Set discount weight. - By Count/PCS PLU: Set discount number |
| 8 | Total Price by total price | - Set a discount amount of total price for current total price. |
| 9 | % Total Price by Total Price | - Set a discount % of total price for current total price |
| 10 | Unit Price by Total Price | - Set a discount amount of unit price for current total price |
| 11 | Extra by Total Price | - Set a discount number of item for current total price |

- ※ Please refer to "para 572" when user wants to also see the unit price discounted on "Unit Price" segment together with total price discounted in display

4. Enter discount value

- Refer to bleow table.

※ Target unit is different depending on the PLU type. This is By Weight PLU therefore this unit is weight. In case of By count PLU or By PCS PLU, unit is count.

EX) 1st Target : 0.100 kg
1st Value : 1.00 \$

2nd Target: 0.500 kg
2nd Value : 2.00 \$

| | | | |
|----------|---------|---------|-------|
| 1 YES | 0 NO | 0 NO | PRINT |
|----------|---------|---------|-------|

| | |
|--------------------------|--------------|
| P1131 PGM | 04-12 |
| 1St Target : [0.100] kg | |

| | | | |
|----------|---------|---------|-------|
| 1 YES | 0 NO | 0 NO | PRINT |
|----------|---------|---------|-------|

| | |
|------------------------|--------------|
| P1131 PGM | 05-12 |
| 1St Value : [1.00] \$ | |

| | | | |
|----------|---------|---------|-------|
| 5 JKL | 0 NO | 0 NO | PRINT |
|----------|---------|---------|-------|

| | |
|--------------------------|--------------|
| P1131 PGM | 06-12 |
| 2ND Target : [0.500] kg | |

| | | | |
|----------|---------|---------|-------|
| 1 YES | 0 NO | 0 NO | PRINT |
|----------|---------|---------|-------|

| | |
|--------------------------|--------------|
| P1131 PGM | 04-12 |
| 1St Target : [0.100] kg | |

| No. | Type | Description |
|-----|----------------------|---|
| 1 | First Target Weight | Set the first weight limit for discount and apply discount for more than limit weight. |
| 2 | First Value Price | Set the discount amount of unit price for the first weight limit. |
| 3 | Second Target Weight | Set the second weight limit for discount and apply discount for more than limit weight. |
| 4 | Second Value Price | Set the discount amount of unit price for the second weight limit. |

5. Discount Condition 1 :
(Set the day of week)

1 → Discount
0 → Do not discount

EX) Discount on Thursday, Friday and Saturday

| | | | | | | | |
|---------|---------|---------|---------|----------|----------|----------|-------|
| 0 NO | 0 NO | 0 NO | 0 NO | 1 YES | 1 YES | 1 YES | PRINT |
|---------|---------|---------|---------|----------|----------|----------|-------|

P1131 PGM **08-12**
Weeks : [0000111]

6. Discount Condition 2 :
(Set date and time)

※ If you set date and time to 0,
it means discount all the time

EX) Start Date : 04-07-01
End Date : 04-07-31

| | | | | | | |
|---------|----------|---------|-----------|---------|----------|-------|
| 0 NO | 4 GHI | 0 NO | 7 PQRS | 0 NO | 1 YES | PRINT |
|---------|----------|---------|-----------|---------|----------|-------|

P1131 PGM **09-12**
S. Date : [04-07-01]

| | | | | | | |
|---------|----------|---------|-----------|----------|----------|-------|
| 0 NO | 4 GHI | 0 NO | 7 PQRS | 3 DEF | 1 YES | PRINT |
|---------|----------|---------|-----------|----------|----------|-------|

P1131 PGM **10-12**
E. Date : [04-07-31]

Start Time : 8 am
End Time : 6:30pm

| | | | | | | |
|---------|----------|---------|---------|---------|---------|-------|
| 0 NO | 8 TUV | 0 NO | 0 NO | 0 NO | 0 NO | PRINT |
|---------|----------|---------|---------|---------|---------|-------|

P1131 PGM **11-12**
S. Time : [08-00-00]

| | | | | | | |
|----------|----------|----------|---------|---------|---------|-------|
| 1 YES | 8 TUV | 3 DEF | 0 NO | 0 NO | 0 NO | PRINT |
|----------|----------|----------|---------|---------|---------|-------|

P1131 PGM **12-12**
E. Time : [18-30-00]

20. Exit Menu

• If you want to exit, press “ESC” key.



2.4.3 List Discount (Menu code 1132)

(MENU → 1. PLU → 3. Discount → 2. List)

1. Enter department number to check

EX) Department No 1.

1
YES PRINT

P1132 PGM **01-03**
Dept No: [1]

2. Enter PLU range to check

EX) PLU 1~99999

• If you want to print list, press the TEST key.

1
YES PRINT

P1132 PGM **02-03**
Start PLU No: [1]

9 **9** **9** **9** **9** PRINT
WXYZ WXYZ WXYZ WXYZ WXYZ

P1132 PGM **03-03**
End PLU No : [99999]

P1131 PGM **03-03**
1 U price

2.4.4 Delete Discount (Menu code 1133)

(MENU → 1. PLU → 3. Discount → 3. Delete)

- ◆ There are three ways to delete Discount. Simply enter the number that you wish to delete.

2.4.5 Delete by PLU No. (DC) (Menu code 1137)

(MENU → 1. PLU → 3. Discount → 3. Delete → 1. Delete by PLU no.(DC))

EX) Department No 1.

1
YES PRINT

P1133 PGM
1. Delete by PLU No. (DC) >1/3

1. Enter the department number and PLU number to delete

EX) Department number = 2
PLU number =1

2
ABC PRINT

Dept No. : [2] **01-02**
Grocery

1
YES PRINT

PLU No. : [1] **02-02**

2.4.6 Delete by Dept. No. (DC) (Menu code 1138)

(MENU → 1. PLU → 3. Discount → 3. Delete → 2. Delete by Dept. No (DC))

EX) Press 2 key to select Delete by Dept. No.(DC)

2
ABC PRINT

P1133 PGM
1. Delete by PLU No. (DC) >1/3

1. Enter the department number to delete

EX) Department number = 2

2
ABC PRINT

Dept No. : [2] **01-01**
Grocery

2.4.7 Delete ALL (DC) (Menu code 1139)

(MENU → 1. PLU → 3. Discount → 3. Delete → 3. Delete ALL(DC))

EX) Press 3 key to select Delete all(DC)

3
DEF PRINT

P1133 PGM
1. Delete by PLU No. (DC) >1/3

1. Enter the department number and PLU number to delete

EX) Press 1 key to select Delete all (DC)

1
YES PRINT

Sure? [Y]

2.5 Global Discount Programming

2.5.1 Global Discount (Menu code 1530)

(MENU → 5. Global Setting → 3. Discount)

You can apply same discount regardless of PLU.

2.5.2 Priority Setting (Menu code 1531)

(MENU → 5. Global → 3. Discount → 1. Priority)

You can set discount type. Refer to Discount Priority Setting Table as below.
You can see discount information on the display by setting of menu 1871 and also you can check it on a label. (See chapter 2.14.21)

► Discount Priority Setting

| No | Type | Description |
|----|--------------------------------|---|
| 0 | No Discount | No discount applied |
| 1 | PLU Discount | PLU discount only applied |
| 2 | Global Discount | Global discount only applied |
| 3 | No Discount in PLU then Global | PLU discount is applied. If there is no PLU discount, apply global discount |

2.5.3 Weight/Count/PCS Discount (Menu code 1532/1533/1534)

(MENU → 5. Global → 3. Discount → 1. Priority)

If you want to apply same discount regardless of PLU, you can set discount information in menu code, 1532, 1533 and 1544. Refer to Discount Programming on chapter 2.4.2

Global Discount condition by weight Item (Menu code 1532)

(MENU → 5. Global Setting → 3. Discount → 2. Weight discount)

Global Discount condition by Count Item (Menu code 1533)

(MENU → 5. Global Setting → 3. Discount → 3. Count discount)

Global Discount condition by PCS Item (Menu code 1534)

(MENU → 5. Global Setting → 3. Discount → 4. PCS discount)

2.6 Speed Key Setting (Menu code 1160)

This menu is to set “speed keys”, one-touch keys, for most frequently used PLUs to simply call up them. You can program up to 5 speed key set. Remember that there is a SHIFT key that allows you to double-use the Speed Keys. The Speed keys are numbered left-to-right and top-to-bottom.

You can use speed key set number when you program menu 1211.(See chapter 2.2.2)

☞ You can not assign the function key as speed keys.

2.6.1 Speed Key (Menu code 1160)

(MENU → 1.PLU → 6.Speed Key)

1. Speed Key Set No.

- Enter speed key set no. You can use this number when you program menu 1211. (See the chapter 2.2.2)

EX) Speed key set No. = 2

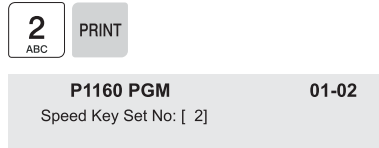

2. Speed Key Programming

- The Speed keys are numbered left-to-right and top-to-bottom. In case of standard type, there are 8 columns and 6 rows for a total of 48 physical keys but if you press the SHIFT key and then one of the 48 Speed keys, then you can access Speed keys 49 through 96. In case of pole type, there are 72 keys but if you press the SHIFT key and then one of the 72 Speed keys, then you can access Speed keys 73 through 144.

EX1) Speed key no. 1

EX2) Speed key no. 49
(In case of standard type)



3. PLU No.

- Enter PLU no. to assign speed key
* PLU should be belong to scale's department.

EX1) PLU 10 = BEEF

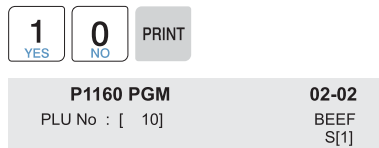

2.7 Programming Store Data

This chapter explains how to access, program STORE data table (Price Look Up) in CL5000 series.

2.7.1 Store Data (Menu code 1410)

(MENU → 4. Store Data Table → 1. Store)

This section shows how to create, edit, list and delete store, customer, and advertisement message data.

2.7.2 New/Edit Store (Menu code 1411)

(MENU → 4. Store Data Table → 1. Store → 1. New/Edit Store)

1. Enter store number.

EX) #1

1
YES PRINT

P1411 PGM

01-04

Store No. : [1]

2. Press "PRINT" key and enter appropriate text in "NAME".

EX) NAME=YANGJOO

PRINT Y A N G J O O
y a n g j o o

P1411 PGM

02-04

Name : [YANGJOO]

3. Press "PRINT" key, then user may enter other store information such as TELEPHONE NUMBER or any text information.

EX) TEL.#=0318200730, TEXT=1 HO

P1411 PGM

03-04

TEL. : [0318200730]

P1411 PGM

04-04

Text : [1 HO]

4. Press "PRINT" key and user may go back to STORE main menu by using "ESC" key.

MENU
ESC

2.7.3 List Store (Menu code 1412)

(MENU → 4. Store Data Table → 1. Store → 2. List Store)

- ➔ This menu shows the list of STORE saved.
- ➔ Press “2” in STORE menu to get into LIST STORE menu.
- ➔ Press “SAVE” key to list all of STORE information saved.

1. Set the list range

- Set the list range to check

EX) 1~10

- ※ If you want to print list, press the TEST key.

| | |
|----------|-------|
| 1 YES | PRINT |
|----------|-------|

| | |
|--------------------|--------------|
| P1412 PGM | 01-02 |
| 1St Number : [1] | |

| | | |
|----------|---------|-------|
| 1 YES | 0 NO | PRINT |
|----------|---------|-------|

| | |
|---------------------|--------------|
| P1412 PGM | 02-02 |
| 2nd Number : [10] | |

| | |
|----------------------|--------------|
| P1412 PGM | 02-02 |
| 1 Yangjoo 0318200730 | |

2.7.4 Delete Store (Menu code 1413)

(MENU → 4. Store Data Table → 1. Store → 3. Delete Store)

- ➔ This menu is to delete the STORE user wish to.
- ➔ Press “3” in STORE menu to get into DELETE STORE menu.

1. Enter cutting hall number to delete

EX) Delete cutting hall no. 1

| | |
|----------|-------|
| 1 YES | PRINT |
|----------|-------|

| | |
|-------------------|--------------|
| P1413 PGM | 01-01 |
| Store No. : [1] | |

2.7.5 Customer (Menu code 1420)

(MENU → 4. Store Data Table → 2. Customer)

This section shows how to register customers' account and their information. Customer information is to manage the specific customer's account receivable.

* Customer registration is used for printing a receipt of credit transactions

2.7.6 New/Edit Customer (Menu code 1421)

(MENU → 4. Store Data Table → 2. Customer → 1. New/Edit)

1. Enter Customer number and press “PRINT” key.

EX1) Customer No.=1,

1
YES PRINT

P1421 PGM 01-07
Customer No. : [1]

2. Enter other informations in [], such as Name, Address1, and Address2.

EX) NAME=BILLY, ADDRESS 1=GARAEBI.
ADDRESS 2=1033/1801

B b ② I i ⑩ L l ⑮ Y y ⑳ PRINT

P1421 PGM 02-07
Name : [BILLY]

G g ① A a ④ R r ⑥ A a ① E e ③ B b ② I i ⑩ PRINT

P1421 PGM 03-07
Address 1 : [GARAEBI]

1 YES 0 NO 3 DEF 3 DEF / ⑬

1 YES 8 TUV 0 NO 1 YES PRINT

P1421 PGM 04-07
Address 2 : [1033/1801]

3. Press “PRINT” key, then user may enter the Address 3, TEL. Number and customer’s CREDIT LIMIT AMOUNT.

EX) TEL.=0318201173
CREDIT LIMIT AMOUNT=200.00

P1421 PGM 05-07
Address 3 : []

0 NO 3 DEF 1 YES 8 TUV 2 ABC 0 NO

1 YES 1 YES 7 PQRS 3 DEF PRINT

P1421 PGM 06-07
TEL. : [0318201173]



P1421 PGM 07-07
Credit Lim : [200.00]

4. Press “PRINT” key to enter the information. User may go back to main CUSTOMER menu by pressing “ESC” key.



2.7.7 List Customer (Menu code 1422)

(MENU → 4. Store Data Table → 2. Customer → 2. List)

- ➔ This menu shows the list of CUSTOMER saved.
- ➔ Press “2” in CUSTOMER menu to get into LIST CUSTOMER menu.
- ➔ Press “SAVE” key to list all of CUSTOMER information saved.

1. Set the list range

- Set the list range to check

EX) 1~89

※ If you want to print list, press the TEST key.



P1422 PGM 01-02
Start Number : [1]

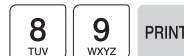

P1422 PGM 02-02
End Number : [89]

P1422 PGM 02-02
BILLY 200.00

2.7.8 Delete Customer (Menu code 1423)

(MENU → 4. Store Data Table → 2. Customer → 3. Delete)

- ➔ This menu is to delete the CUSTOMER user wish to.
- ➔ Press “3” in CUSTOMER menu to get into DELETE CUSTOMER menu.
- ➔ Enter customer number to delete.

1. Enter cutting hall number to delete

EX) Delete cutting hall no. 1



| | |
|-------------------|--------------|
| P1423 PGM | 01-01 |
| Store No. : [1] | |

2.7.9 Scroll Message (Menu code 1430)

(MENU → 4. Store Data Table → 3. Scroll Message)

This function is to set the scrolling advertisement on LCD Display.

2.7.10 Configuration (Menu Code 1431)

(MENU → 4. Store Data Table → 3. Scroll Message → 1. Configuration)

1. Configuration

- User may set the wait time from 1 to 9999 second. Setting wait time as '0' is not to use "Scroll Message" function.



EX) Wait Time = 5

| | |
|------------------------|--------------|
| P1431 PGM | 01-01 |
| Wait Time (1s) : [5] | |

2.7.11 Edit Scroll Message (Menu Code 1432)

(MENU → 4. Store Data Table → 3. Scroll Message → 2. Edit Scroll Message)

1. Input and edit Message

- User may input up to five messages and select two different scrolling effect. Please input messages No. and message.

| | |
|------------------|--------------|
| P1432 PGM | 01-06 |
| Msg No. : [1] | |

| | |
|-----------------------------|--------------|
| P1432 PGM | 02-06 |
| Msg : [Scroll Message....] | |

2. Enter Speed

- Speed means the message scrolling speed. User May set it from 1 to 9.

| | |
|-------------------|--------------|
| P1432 PGM | 03-06 |
| Speed(0.1s):[1] | |

3. Enter Blink Counts

EX) 1.

| | |
|--------------------|--------------|
| P1432 PGM | 04-06 |
| Blink Counts:[1] | |

| | |
|------------------|--------------|
| P1432 PGM | 05-06 |
| Effect : [2] | LtoR |

4. Set scrolling message effect

Effect =1 : Scroll message right to left
Effect =2 : Scroll message left to right
Effect =3 : Scroll message blink

If you set [N] at Use Setting,
this scrolling message is not use.
If it use this scroll, then set [Y]

P1432 PGM

06-06

Effect : [1]
Use message (Y/N) : [Y]

2.7.12 List Scroll Message (Menu Code 1433)

(MENU → 4. Store Data Table → 3. Scroll Message → 3. List)

This function is to set the scrolling advertisement on LCD Display.

1. Set the list range

- Set the list range to check

EX) 1~9

1
YES PRINT

P1433 PGM

01-02

1st Number : [1]

9
WXYZ PRINT

P1433 PGM

02-02

2nd Number : [9]

2.7.13 Currency (Menu code 1440)

(MENU → 4. Store Data Table → 4. Currency)

User may save rate of currency to default currency and convert to another currency simply by this function.

☞ Please refer to "Menu 1880 Function key definition".

2.7.14 New/Edit Currency (Menu Code 1441)

(MENU → 4. Store Data Table → 4. Currency → 1. New/Edit)

1. Numbering Currency

- User may save up to 4 different currencies by numbering 1~4.

EX) Currency No. = 1

1
YES PRINT

P1441 PGM

01-07

Enter Currency No : [1]

2. Rate Decimal Point

- Enter the Rate Decimal Point (default = 4)

EX) Rate Decimal Point = 3

| | |
|----------|-------|
| 3 DEF | PRINT |
|----------|-------|

| | |
|--------------------------|--------------|
| P1441 PGM | 02-07 |
| Rate Decimal Point : [4] | |

3. Currency Rate.

- Enter comparative rate of currency to default currency set.

EX) Default currency = \$1.00

Comparative currency rate to default
currency = €1.2800.

| | | | | | |
|----------|----------|----------|---------|---------|-------|
| 1 YES | 2 ABC | 8 TUV | 0 NO | 0 NO | PRINT |
|----------|----------|----------|---------|---------|-------|

| | |
|---------------------------|--------------|
| P1441 PGM | 03-07 |
| Currency Rate : [12.800] | |
| Primary Sign : [] | |

4. Primary Sign

- Enter the first currency sign to be changed.

EX) Primary Sign = \$

| | | | |
|------|----------|---------|-------|
| CODE | 8 TUV | 0 NO | PRINT |
|------|----------|---------|-------|

| | |
|----------------------|--------------|
| P1441 PGM | 04-07 |
| Primary Sign : [\$] | |

5. Last Symbol

- Enter the last currency symbol to be changed.

EX) No last symbol

| |
|-------|
| PRINT |
|-------|

| | |
|------------------|--------------|
| P1441 PGM | 05-07 |
| Last Sign : [] | |

6. Price Decimal Digit

- Enter the number of decimal digit

EX) Price Decimal point digit = 2

| | |
|----------|-------|
| 2 ABC | PRINT |
|----------|-------|

| | |
|---------------------------|--------------|
| P1441 PGM | 06-07 |
| Price Decimal Point : [2] | |

7. Price Output Form

- Enter the number

EX) Price Output Form = 1

| | |
|----------|-------|
| 1 YES | PRINT |
|----------|-------|

| | |
|-------------------------|--------------|
| P1441 PGM | 07-07 |
| Price Output Form : [1] | |

► Printing formats of currency symbol

| No | Printing Format | Remarks |
|----|-----------------------------|---|
| 0 | "100.00", "0.12" | |
| 1 | "\$ 100.00", "\$ 0.12" | |
| 2 | "100.00 \$", "0.12 \$" | |
| 3 | "\$ 100.00 c", "\$ 0.12c" | |
| 4 | "\$ 100.00 c", "12c(Greek)" | When total amount is less than 1, only "Last currency symbol" shows up. |
| 5 | "\$100.00", "\$0.12" | |
| 6 | "100.00\$", "0.12\$" | |
| 7 | "\$100.00c", "\$0.12c" | |
| 8 | "\$100.00c", "12c(Greek)" | When total amount is less than 1, only "Last currency symbol" shows up. |

2.7.15 List Currency (Menu Code 1442)

(MENU → 4. Store Data Table → 4. Currency → 2. List)

1. Set the list range

- Set the list range to check

EX) 1~4

※ If you want to print list, press the TEST key.

1
YES PRINT

P1442 PGM 01-02
1St Number: [1]

4
GHI PRINT

P1442 PGM 02-02
2nd Number : [4]

P1442 PGM 02-02
1 1.2800 \$

2.7.16 Delete Currency (Menu code 1443)

(MENU → 4. Store Data Table → 4. Currency → 3. Delete)

1. Currency number to delete

EX) Delete Currency no. 2

2
ABC PRINT

P1443 PGM 01-01
Enter Currency No : [2]

2.8 Programming Global Setting

2.8.1 Global Label Format (Menu code 1510)

(MENU → 5. Global Setting → 1. Label Format)

Pre-programmed fixed label formats are from #1 to #10 and these formats cannot be modified.

Label format #11~#30 are free formats that users may modify at their needs. Users may download one into the scale and set a specific free label format. (Refer to 4.2 Label format on chapter 2.14.20)

- ◆ You can press the SAVE key at anytime to save the current data and if you want to exit without saving, press the ESC key.

1. Global Label

- If you use Global Label, enter 1. If not, enter 0.
- * If you set it to 1, 1st format number is ignored which is set in PLU programming
- * 2nd label format is printed if it is set.

1
YES PRINT

P1510 PGM 01-06
Use Global Label: [Y]

EX) Use global label

2. Set PLU label No.

- Set PLU label number

2
ABC PRINT

P1510 PGM 02-06
PLU Label No.: [2] 60x40

EX) PLU Label No. = 2. IS6040-0000(60x40)

3. Set Miscellaneous label number

- Set label format for miscellaneous item.

2
ABC PRINT

P1510 PGM 03-06
Misc. Label No.: [2] 60x40

EX) Misc. Label ID = 2. IS6040-0000(60x40)

4. Set total label number

- Set label format of total label for Add-Up sales.

1 YES 0 NO PRINT

P1510 PGM 04-06
Total Label No.: [10] 60x40

EX) Total label No. = 10 , TC6060-0002(60x60)

5. Set printing direction of total label

EX) Reverse Total Label = “Y”



6. Set printing direction of PLU and Misc. item

EX) Reverse Item Label = “Y”



7. Exit Menu

- If you want to exit, press “ESC” key.



2.8.2 Barcode Format (Menu code 1520)

(MENU → 5. Global Setting → 2. Barcode)

Global Barcode Setting provides all-in-one barcode setting by selecting nine different barcode options so that user does not need to save data for individual PLUs one by one. All related barcode data are selected and saved from PLU barcode data table user may already register.

- ◆ You can press the SAVE key at anytime to save the current data and if you want to exit without saving, press the ESC key.

1. Set Global Barcode

- If you use global barcode, enter 1. If not, enter 0.
- * If you set it to 1, barcode number is ignored which is set in PLU programming

EX) Use global barcode



2. Set barcode number for by-weight PLU

EX) PLU Weight barcode No. = 2



3. Set barcode number for by-count PLU

EX) PLU Count barcode No. = 2



P1520 PGM

03-10

PLU Count Barcode : [2]

4. Set barcode number for by-PCS PLU

EX) PLU PCS barcode No. = 2



P1520 PGM

04-10

PLU PCS Barcode : [2]

5. Set barcode number for fixed PLU

EX) PLU fixed barcode No. = 2



P1520 PGM

05-10

PLU Fixed barcode : [2]

6. Set barcode number for Misc. weight item

EX) Misc. weight barcode No. = 2



P1520 PGM

06-10

Misc. Weight Barcode : [2]

7. Set barcode number for Misc. count item

EX) Misc. count barcode No. = 2



P1520 PGM

07-10

Misc. Count Barcode : [2]

8. Set barcode number for Misc. PCS Item

EX) Misc. PCS barcode No. = 2



P1520 PGM

08-10

Misc. pcs Barcode : [2]

9. Set barcode number for Add-Up Total

EX) Add Up TTL barcode No. = 2



10. Set barcode number for floating Total

EX) Floating TTL barcode No. = 2

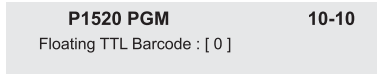

11. Exit Menu

- If you want to exit, press “ESC” key.



2.9 Printing Programming

This chapter explains how to set printing-related environments, such as print label item, markdown, Hardware, serial # format, and ticket.

2.9.1 Printing (Menu code 1700)

(MENU → 7. Print)

P1700 PGM

1. Print Label Item

>1/6

► PRINT Submenu

| No | Submenus | Description |
|----|------------------|---|
| 1 | Print Label Item | Select item(s) which is(are) not printed on label. |
| 2 | Markdown | Select "Yes" or "No" to print both of original and discount information on the label. |
| 3 | Print Hardware | Set the label type and sensor of printer |
| 4 | Serial # Format | Set the format of serial number to print label or ticket |
| 5 | ADD-UP Total | Select add-up total label whether is printed or not |
| 6 | Ticket | Set printing item for ticket |

2.9.2 Print label item (Menu code 1710)

(MENU → 7. Print → 1. Print Label Item)

If you set any of the items to Y, then they will NOT print on any labels regardless of the label format.

You can use the PG UP and PG DOWN keys to navigate from page to page, or you can use the Arrow keys to go through each page 1 line at a time.

- ◆ You can press the SAVE key at anytime to save the current data and if you want to exit without saving, press the ESC key.

**1. If you do not want to print, enter 0(N),
if you want to print, enter 1(Y).**

| | | | | |
|--|-------|----|---|-------|
| <input type="text" value="1"/> <small>YES</small> | PRINT | or | <input type="text" value="0"/> <small>NO</small> | PRINT |
|--|-------|----|---|-------|

P1710 PGM

01-51

Department Name : [N]

► Print Label Item

| Page | Item | Page | Item |
|------|---------------------|------|--------------------|
| 1 | Department Name | 27 | Percent Tare |
| 2 | Department Number | 28 | Percent Tare Limit |
| 3 | Group Number | 29 | Saved Price |
| 4 | PLU Number | 30 | Label Serial |
| 5 | PLU Name 1 | 31 | Store Name |
| 6 | PLU Name 2 | 32 | Clerk Number |
| 7 | PLU Name 3 | 33 | Clerk Name |
| 8 | Item Code | 34 | Customer Name |
| 9 | Unit Weight | 35 | Customer Number |
| 10 | Tax Rate | 36 | Scale Number |
| 11 | Tax Price | 37 | Day of Week |
| 12 | Tare Weight | 38 | Currency Rate |
| 13 | Pieces | 39 | Second Total Price |
| 14 | Unit Symbol | 40 | Second Unit Price |
| 15 | Sell By Date | 41 | Traceability |
| 16 | Sell By Time | 42 | Nutrition Fact |
| 17 | Packed On Date | 43 | Label Caption |
| 18 | Packed On Time | 44 | Total Tax Price |
| 19 | Produced Date | 45 | Second Add Total |
| 20 | Cook By Date | 46 | Barcodes |
| 21 | Bonus Point | 47 | Image |
| 22 | Origin | 48 | Weight |
| 23 | Ingredient | 49 | Quantity |
| 24 | Sales Message | 50 | Unit Price |
| 25 | Refer. Net Weight | 51 | Total Price |
| 26 | Refer. Gross Weight | | |

2.9.3 Markdown (Menu code 1720)

(MENU → 7. Print → 2. Markdown)

Markdown is to select “Yes” or “No” to print both of original and discount information on the label. There are 4 selectable sub-menus on label.

► Markdown Sub-menu

| No | Sub-menu | Description |
|----|----------------------|---|
| 1 | Total Price Markdown | Select “Yes” to display both of original total price and discount total price if any. Otherwise |
| 2 | Unit Price Markdown | Select “Yes” to display both of original unit price and discount unit price if any. Otherwise |
| 3 | Weight Markdown | Select “Yes” to display both of original weight and discount weight if any. Otherwise |
| 4 | Quantity Markdown | Select “Yes” to display both of original quantity and discount quantity if any. Otherwise |

1. Select Yes or No by using 1 or 0 key and press the PRINT key.

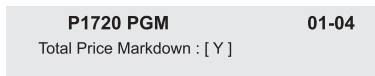
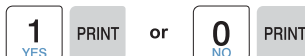

2. After setting all of above MARK DOWN sub-menus use “ESC” key or “SAVE” key to go back to PRINT main menu.



2.9.4 Printer Hardware (Menu code 1730)

(MENU → 7. Print → 1. Printer Hardware)

This section is to explain how to set printing H/W environments in the following table.

1. Press “3” to get into H/W setting mode on Print Menu.

3
DEF

P1730 PGM

1. Print Mode

>1/8

► Printer Hardware Sub-Menu

| No. | Sub-menu | Description |
|-----|---------------------|---|
| 1 | Print Mode | Select label, ticket or continuous label mode. |
| 2 | Label / Ticket Size | If it is Label mode, “Width(60)”, “Height(40)” and “Gap length(2)” size is set, If it is Ticket mode, “Width(60)”, “Feed(20)” and “End Margin(5)” size is set. If you use Continuous Label Paper in Label mode, “Gap length” value is applied to “End Margin”. * The values in () are default. |
| 3 | Sensor Calibration | Enter the “Gap(128)” and “Peel(128)” values for printing sensor calibration. * The values in () are default. * If you press “TEST” key, Gap and Peel values are adjusted automatically. * In case of Ticket mode, Gap value is not saved. |
| 4 | Sensor & Motor | Set Peel-off sensor, Rewind Motor and Label Paper type |
| 5 | Print Intensity | Set the extent of intensity of label (ticket) printed. |
| 6 | Adjust Feed Length | Set adjusting values of feed length. This value can be from -200 to +200. You can change sign(+,-) by pressing ZERO key. + value will print higher than THP. * Pressing “TEST” key automatically feeds to adjust the feed length. |
| 7 | Label Preprint | You can set preprint length. |
| 8 | Printer Speed | You can set printer speed |

2.9.5 Print Mode (Menu code 1731)

(MENU → 7. Print → 3. Printer Hardware → 1. Print Mode)

Select “0” for Label Mode, “1” for Ticket Mode or “2” for Continuous Label Mode.

- Press “PRINT” to save.

P1730 PGM

Print Mode (0-2) : [0]

01-01

Label M

2.9.6 Label Size/Ticket Size (Menu code 1732)

(MENU → 7. Print → 3. Printer Hardware → 2. Label Size)

Enter values for “Width”, “Height”, “Gap Length”.
If you press “TEST” key, height and gap length of current label is measured.

- * If it is Ticket Mode, “TICKET SIZE” is displayed, and “TEST” key is not operated.
- * If it is Label mode and Continuous Label Paper, “TEST” key is not operated. And "End Margin" instead of "Gap Length" shows up.

P1732 PGM

W[60],H[40],G[2]

01-01

P1732 PGM

W[60]mm

01-01

2.9.7 Sensor Calibration (Menu code 1733)

(MENU → 7. Print → 3. Printer Hardware → 3. Sensor Calibration)

Enter appropriate values for “Gap”, “Peel”, “Out of Paper”.

- * If you press “TEST” key, Gap and Peel values are adjusted automatically.
- * If it is Ticket mode, “Gap” value is not saved.

P1732 PGM

W[60],H[40],G[2]

01-01

P1732 PGM

W[60]mm

01-01

2.9.8 Sensor & Motor (Menu code 1734)

(MENU → 7. Print → 3. Printer Hardware → 4. Sensor & Motor)

Enter appropriate values or “Yes” or “No” for “PRINT METHOD TYPE”, “ACTIVE PEEL-OFF”, “ACTIVE REWIND MOTOR”, and “LABEL PAPER”.

- * If there is no gap on a label, set Label Paper to 0, if there a gap, set it to 1.
- * When "Ticket Mode" is in "Print Mode", [Rewind Motor] and [Labe Paper] do not work.

| | |
|------------------|--------------|
| P1734 PGM | 01-03 |
| Active Peel-off | : [Y] |

| | |
|---------------------|--------------|
| P1734 PGM | 02-03 |
| Active Rewind Motor | : [Y] |

| | |
|------------------|--------------|
| P1734 PGM | 03-03 |
| Label Paper Gap | : [Y] |

2.9.9 Print Intensity (Menu code 1735)

(MENU → 7. Print → 3. Printer Hardware → 5. Print Intensity)

Enter any value from “0” to “20”.
Press “TEST” to test printing a label.

| | |
|-------------------|--------------|
| P1735 PGM | 01-01 |
| Printer Intensity | : [10] |

2.9.10 Adjust Feed Length (Menu code 1736)

(MENU → 7. Print → 3. Printer Hardware → 6. Adjust Feed Length)

Enter any value of the feed alignment from “-200” to “+200”.
Press “ZERO” to toggle sign.
Press “TEST” to test feed or “ENTER” to save current “FEED Length value.

| | |
|-----------------------|--------------|
| P1736 PGM | 01-01 |
| Feed Adj (+200);[- 0] | MAX +200 |

* 1pixel = 0.125mm

EX) “+80” will print 10mm higher.
“-40” will print 5mm lower.

2.9.11 Label Preprint (Menu code 1737)

(MENU → 7. Print → 3. Printer Hardware → 7. Label Preprint)

Enter “Y(Yes)” or “N(No)” to select Preprint mode and any value of the preprint length from “0”mm to “10”mm. Press “TEST” to test preprinting.

After setting all of above H/W setting sub-menus use “ESC” key to go back to PRINT main menu.

MENU
ESC

P1737 PGM 01-02

Pre-print Mode : [N]

P1737 PGM 02-02

Pre-print Length : [10]

2.9.12 Label Preprint (Menu code 1738)

(MENU → 7. Print → 3. Printer Hardware → 8.Printer Speed)

Select Printer Speed

EX) Speed 3

P1738 PGM 01-01

Printer Speed : [3]

110mm

| No. | Speed |
|-----|-------|
| 0 | 60mm |
| 1 | 90mm |
| 2 | 100mm |
| 3 | 110mm |

2.9.13 Serial # Format (Menu code 1740)

(MENU → 7. Print → 4. Serial # Format)

SERIAL # FORMAT programming is for numbering of label/ticket issued (printed) on label/ticket. User may identify daily total counts of label/ticket used up.

① Press “4” to go to SERIAL NUMBER FORMAT menu in PRINT main menu.

4
GHI

② Enter appropriate data in [].

EX) #0001 on label
RCT#001 on ticket

| | | | | | | |
|---------------------------|---|---|---|---|---|--------------|
| % | # | B | B | B | B | PRINT |
| | | b | b | b | b | |
| P1740 PGM | | | | | | 01-02 |
| LB Serial No. : [%#BBBB] | | | | | | |

| | | | | | |
|------------------------------|---|---|---|--------------|--|
| % | R | % | C | % | |
| | r | | c | | |
| T | A | A | A | PRINT | |
| t | a | a | a | | |
| P1740 PGM | | | | 02-02 | |
| TK Serial No. : [%R%C%TAAA] | | | | | |

| Meaning |
|--|
| I : Item Code |
| N : PLU Number |
| P : Price |
| U : Unit Price |
| W : Weight |
| Q : Quantity |
| D : Department |
| G : group |
| A : Ticket Counter (Ticket Mode) |
| B : Scale Transaction Counter |
| F : PLU Prefix Character |
| T : Text Character |
| R : Transaction Counter of Each PLU |
| L : Clerk Number |
| % : Print Fixed Character in the Next Space. |
| K : Country Code (For Future) |

| Sample Label Serial Number | Sample Ticket Serial Number | | | | | | | | | | | | | | | | | | | | | | | | | | | | | | | | | |
|---|-----------------------------|-------------|-------|-----------|---------------------------|-------|---|----|-------|----|-------------------|--|--|--------|---------|----------|---------------|--|--|--------|---------|----------|-----------------|--|--|---------|--------|--|--------------|--|--|--|-----------|--|
| <div data-bbox="222 394 568 625" style="border: 1px solid black; padding: 10px;"> <p style="text-align: center; font-size: 1.2em; margin: 0;">W. Melon</p> <p style="text-align: right; margin: 0;">#0012</p> <table style="width: 100%; border-collapse: collapse; margin: 5px 0;"> <tr> <td style="font-size: 0.8em;">PACKED ON DATE</td> <td style="font-size: 0.8em;">PRICE \$/kg</td> <td style="font-size: 0.8em;">WT kg</td> </tr> <tr> <td style="font-size: 0.8em;">04-JUL-28</td> <td style="font-size: 0.8em;">20.00 19.00</td> <td style="font-size: 0.8em;">1.000</td> </tr> </table> <div style="text-align: center; margin: 5px 0;">  </div> <p style="font-size: 0.8em; margin: 0;">TOTAL PRICE \$ 20.52 20.44</p> <p style="text-align: center; margin: 0;">CAS CORPORATION</p> </div> | PACKED ON DATE | PRICE \$/kg | WT kg | 04-JUL-28 | 20.00 19.00 | 1.000 | <div data-bbox="638 256 983 760" style="border: 1px solid black; padding: 10px;"> <p style="margin: 0;">MANAGER(0) 04-AUG-16(MON) 18:49:51 AM</p> <hr/> <table style="width: 100%; border-collapse: collapse;"> <thead> <tr> <th style="text-align: left; font-size: 0.8em;">kg</th> <th style="text-align: left; font-size: 0.8em;">\$/kg</th> <th style="text-align: left; font-size: 0.8em;">\$</th> </tr> </thead> <tbody> <tr> <td colspan="3" style="padding-top: 10px;">STRAWBERRY</td> </tr> <tr> <td style="font-size: 0.8em;">14.995</td> <td style="font-size: 0.8em;">9999.99</td> <td style="font-size: 0.8em;">99999.99</td> </tr> <tr> <td colspan="3" style="padding-top: 5px;">BANANA</td> </tr> <tr> <td style="font-size: 0.8em;">14.995</td> <td style="font-size: 0.8em;">9999.99</td> <td style="font-size: 0.8em;">99999.99</td> </tr> <tr> <td colspan="3" style="padding-top: 10px;">SUBTOTAL</td> </tr> <tr> <td style="font-size: 0.8em;">2 ITEMS</td> <td style="font-size: 0.8em;">266.67</td> <td></td> </tr> <tr> <td colspan="3" style="padding-top: 10px;">TOTAL</td> </tr> <tr> <td></td> <td style="font-size: 0.8em;">\$ 266.67</td> <td></td> </tr> </tbody> </table> <p style="text-align: right; margin: 10px 0;">RCT#023</p> </div> | kg | \$/kg | \$ | STRAWBERRY | | | 14.995 | 9999.99 | 99999.99 | BANANA | | | 14.995 | 9999.99 | 99999.99 | SUBTOTAL | | | 2 ITEMS | 266.67 | | TOTAL | | | | \$ 266.67 | |
| PACKED ON DATE | PRICE \$/kg | WT kg | | | | | | | | | | | | | | | | | | | | | | | | | | | | | | | | |
| 04-JUL-28 | 20.00 19.00 | 1.000 | | | | | | | | | | | | | | | | | | | | | | | | | | | | | | | | |
| kg | \$/kg | \$ | | | | | | | | | | | | | | | | | | | | | | | | | | | | | | | | |
| STRAWBERRY | | | | | | | | | | | | | | | | | | | | | | | | | | | | | | | | | | |
| 14.995 | 9999.99 | 99999.99 | | | | | | | | | | | | | | | | | | | | | | | | | | | | | | | | |
| BANANA | | | | | | | | | | | | | | | | | | | | | | | | | | | | | | | | | | |
| 14.995 | 9999.99 | 99999.99 | | | | | | | | | | | | | | | | | | | | | | | | | | | | | | | | |
| SUBTOTAL | | | | | | | | | | | | | | | | | | | | | | | | | | | | | | | | | | |
| 2 ITEMS | 266.67 | | | | | | | | | | | | | | | | | | | | | | | | | | | | | | | | | |
| TOTAL | | | | | | | | | | | | | | | | | | | | | | | | | | | | | | | | | | |
| | \$ 266.67 | | | | | | | | | | | | | | | | | | | | | | | | | | | | | | | | | |

2.9.14 Add-Up Total (Menu code 1750)

(MENU → 7. Print → 5. Add-up Total)

This section shows how to set printing environments of total label and item label when you use ADD-UP sales.

- ① Press “5” to get into ADD-UP TOTAL menu in PRINT main menu.

5
JKL

P1750 PGM 01-02

Prt. Total Label: [Y]

- ② Press “0” for “No” or “1” for “Yes” in [].

1
YES
PRINT
0
NO

EX) Print Total Label - Yes
Print Item Label - No

P1750 PGM 02-02

Prt. Item Label: [N]

- ③ Press “PRINT” key to save and go back to PRINT main menu



▶ ADD-UP Setting

| ADD-UP Setting | Description |
|-------------------|--|
| Print Total Label | Total label is printed when you press the PRINT key during add-up sales. |
| Print Item Label | Item label is printed whenever you press the ADD key. |

※ It is applied to Label mode.

2.9.15 Ticket (Menu code 1760)

(MENU → 7. Print → 6. Ticket)

This section shows how to select item(s) (Contents) printed on ticket.

- ① Press “6” to go to TICKET setting.



P1760 PGM
1. Select Ticket Item >1/3

2.9.16 Select Ticket Item (Menu code 1761)

(MENU → 7. Print → 6. Ticket → 1. Select Ticket Item)

- ① Press “1” to go to SELECT TICKET ITEM menu.
Select “Yes” or “No” for “Print List”, “Print Total Barcode”, and “Print Total Label”.
“Print Duplicute ticket”, “Print List Duplicute ticket”



P1761 PGM 01-05
Prt. List : [Y]



P1761 PGM 02-05
Prt. Total Barcode : [Y]

1
YES PRINT

P1761 PGM 03-05

Prt. Total Label : [Y]

1
YES PRINT

P1761 PGM 04-05

Prt. Duplicate Ti : [Y]

1
YES PRINT

P1761 PGM 05-05

Prt. List (D.Ticke) : [Y]

2.9.17 Select List Item (Menu code 1762)

(MENU → 7. Print → 6. Ticket → 2. Select List Item)

Before setting list item, you have to set "Print List" to "Y" in menu 1761.

- ① Press "2" to get into SELECT LIST ITEM menu.
Select "Yes" or "No" for "Print Store Name", "Print Clerk Name", and "Print Item Barcode".

2
ABC 1
YES PRINT

P1762 PGM 01-07

Prt. Store Name : [Y]

1
YES PRINT

P1762 PGM 02-07

Prt. Clerk Name : [Y]

1
YES PRINT

P1762 PGM 03-07

Prt. Item Barcode : [Y]

② Select “Yes” or “No” for “Print Tax Information”, and “Print Traceability”. And, select appropriate ID # for “Ticket Head Form” and “Ticket Tail Form”.

1
YES PRINT

P1762 PGM 04-07
Prt. Tax Information : [Y]

1
YES PRINT

P1762 PGM 05-07
Prt. Traceability : [Y]

2
ABC PRINT

P1762 PGM 06-07
Ticket Head Form : [2]

3
DEF PRINT

P1762 PGM 07-07
Ticket Tail Form : [3]

► Ticket Format Setting

| | Ticket Format Setting | Description |
|-------------|-----------------------|---|
| Ticket Item | Print List (Y/N) | ■ Printing the list of each sales item(s). * In case of “Yes” selected user can go to “List Item” setting. |
| | Print Total Barcode | ■ Printing total barcode on ticket. |
| | Print Total Label | ■ Printing total amount on ticket. |
| List Item | Print Store Name | ■ Printing store name on ticket. |
| | Print Clerk Name | ■ Printing clerk name on ticket. |
| | Print Item Barcode | ■ Printing every item’s barcode on ticket. |
| | Print Tax Information | ■ Printing tax information on ticket. |
| | Print Traceability | ■ Printing traceability information on ticket |
| | Ticket Head Form No. | ■ Printing label format No. for ticket head. |
| | Ticket Tail Form No. | ■ Printing label format No. for ticket tail. |

※ You have to download label format for Ticket Head Form No. and Ticket Tail Form No. from PC.

◆ Ticket Format

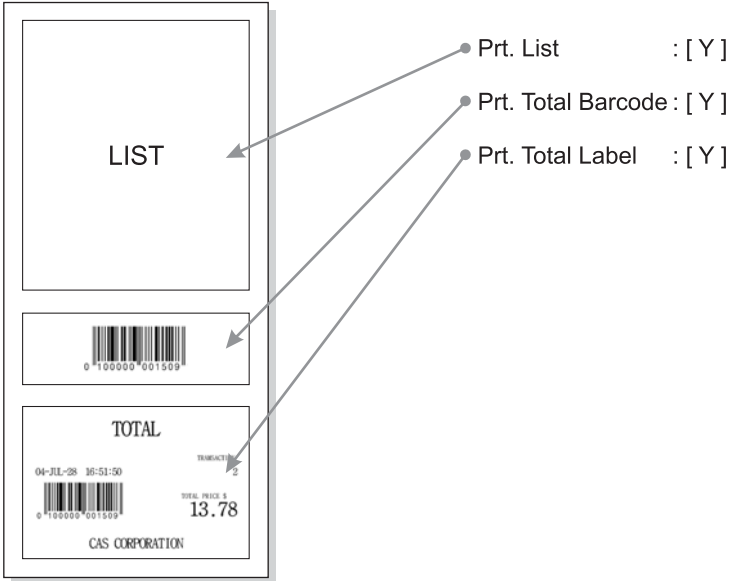

◆ List Format

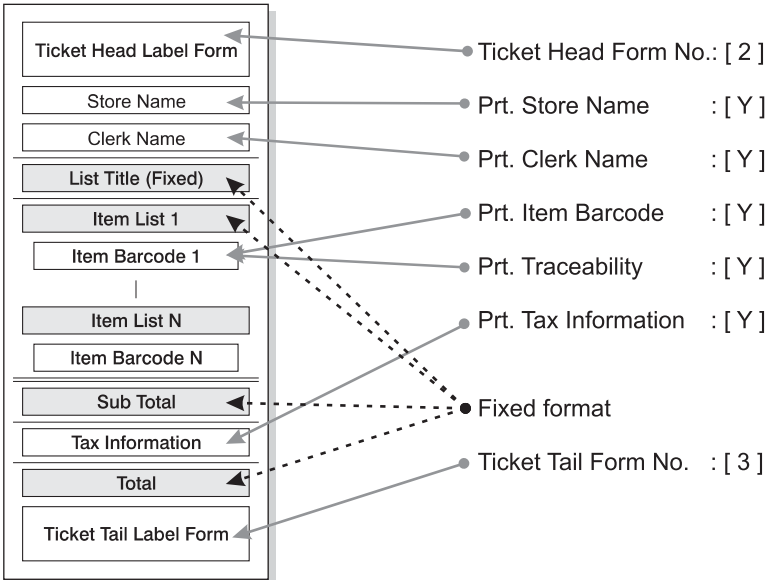

2.9.18 Select Ticket Font Size (Menu code 1763)

(MENU → 7. Print → 6.Ticket → 3. Select Ticket Font Size)

1.If you do not want to print, enter 0(N),
if you want to print, enter 1(Y).

YES or NO

| No. | Item |
|-----|-------------------|
| 1 | PLU Name |
| 2 | Transaction Data |
| 3 | Total Value |
| 4 | Ticket Serial No. |

P1763 PGM 01-04
PLU Name : [Y]

P1763 PGM 02-04
Transaction Data : [Y]

P1763 PGM 03-04
Total Value : [Y]

P1763 PGM 04-04
Ticket Serial No : [Y]

2.10 Programming Scale Configuration

2.10.1. Scale Configuration (Menu code 1800)

(MENU → 8. Scale Config)

This chapter explains how to configure the scale. The main menu of “Scale Configuration” is shown as below.

| No. | Item |
|-----|-----------------------------|
| 1 | Sale Mode |
| 2 | Operation Mode |
| 3 | Department |
| 4 | Date/Time |
| 5 | User/Security Configuration |
| 6 | Test |
| 7 | Scal Parameter |
| 8 | Function Key Define |

2.10.2 Sale Mode (Menu code 1810)

(MENU → 8. Scale Config → 1. Scale Mode)

This section is to select sale mode, which have six different modes in the following table.

► Sale Modes

| No. | Sale Modes | Description |
|-----|------------------------|--|
| 1 | REG: Ticket & Floating | Selecting Ticket and Floating Clerk Mode. |
| 2 | REG: Label | Selecting label Mode. |
| 3 | REG: Prepack | Selecting Prepack Mode. |
| 4 | REG: Label & Floating | Selecting Label and Floating Clerk Mode. |
| 5 | Manager | Selecting Manager Mode |
| 6 | Repack | Selecting Repack Mode (In this mode, report is not updated.) |
| 7 | Self Service & Label | Selecting Self Service Mode (In this mode, you can use speed key and some keys. If you want to finish this mode, while pressing MENU key, enter system password and PRINT key) |

- ▶ Selecting one of following sale modes, user may select an one-stop setting for Clerk, Operation, Print, and Prepack mode.

| MODE | Clerk Mode | Operation Mode | Print Mode | Prepack Mode |
|---------------------------|----------------|----------------|------------|--------------|
| 1. REG: Ticket & Floating | Floating Clerk | Regist | Ticket | OFF |
| 2. REG: Label | No Clerk | Regist | Label | OFF |
| 3. REG: Prepack | No Clerk | Regist | Label | ON |
| 4. REG: Label & Floating | Floating Clerk | Regist | Label | OFF |
| 5. Manager | - | Manager | - | OFF |
| 6. Repack | - | Repack | - | OFF |
| 7. Self Service & Label | - | - | Label | OFF |

Usually user has to set each option you wish to for clerk, operation, print or prepack mode. However, user may select simply one-stop sales mode for 7 different modes- Clerk, Operation, Print, and Prepack mode. User may also set options for Clerk/Operation mode in MENU 1820 and Print/Prepack mode in MENU 1731.

1. Select a sale mode



EX) Sale mode = 2.REG: Label



2. Select "Floating & Ticket" mode



EX) Sale mode = 1.REG: Ticket & Floating



2.10.3 Operation Mode (Menu code 1820)

(MENU → 8. Scale Config → 2. Operation Mode)

This section is to select a clerk and operation mode. There are three different operation modes, REGISTRATION, RE-PACK, MANAGER and three different clerk modes, NO CLERK, STANDARD CLERK, and FLOATING CLERK.

► Clerk Modes

| No | Clerk Modes | Description |
|----|----------------|--|
| 1 | No Clerk | Sales clerk do not log in and makes sales using "PRINT" key. |
| 2 | Standard Clerk | Sales clerk can make sales when he/she logs in. |
| 3 | Floating Clerk | Plural sales clerks can make sales using own clerk ID. |

► Operation Modes

| No | Operation Modes | Description |
|----|-----------------|--|
| 1 | Registration | Normal sales mode. |
| 2 | Repack | Normal sales mode but not included in total sales data(report). Good for clerk training. |
| 3 | Manager | In this mode user can access all of functions without any permission. |

1. Select appropriate "CLERK MODE" and "OPERATION MODE".

2 PRINT
ABC

EX) Clerk Mode=Standard Clerk

P1820 PGM **01-02**
Select Clerk Sale : [2] Stand

Operation Mode=Registration

1 PRINT
YES

P1820 PGM **02-02**
Select Oper Mode : [1] Regis

2.10.4 Department (Menu code 1830)

(MENU → 8. Scale Config → 3. Department)

This section shows how to select current department where scale is being used. User can use (call up) PLUs only for current department selected in sales mode.

For example, if current department selected is GROCERY user can call up items registered only in GROCERY department. If user would like to use PLUs registered in other department than current department he/she should change scale's department setting.

Store No. represents Store Name (or branch number) on label/ticket printed.

1. Select “DEPARTMENT No.” and “STORE ID”.

EX) DEPARTMENT No.= 2 (Grocery)

2
ABC PRINT

P1830 PGM **01-02**
Dept No. : [2] Grocery

STORE No.= 1 (Branch #1)

1
YES PRINT

P1830 PGM **02-02**
Store No. : [1] Branch #1

2.10.5 Date & Time (Menu code 1840)

(MENU → 8. Scale Config → 4. Date/Time)

This section is to set scale’s DATE & TIME appropriately.

1. Set appropriate “DATE”, “TIME”, and “MONTH FORMAT”.

EX) ATE= [07.02.04]
TIME= [10:30:00]
Month Format= [1]

P1840 PGM **01-07**
Date : [07.02.04]

P1840 PGM **02-07**
Time : [10:30:00]

P1840 PGM **03-07**
Month Format: [1] NUMBER

2. Set “YEAR FORMAT”, “TIME FORMAT” and separator for “DATE”.

EX) Year Format (0=2001, 1=01) = [1]
Time Format(0~3) = [1]
Date Separator= [-]

P1840 PGM **04-07**
Year Format : [1] 2 DIGIT

P1840 PGM **05-07**
Time Format: [1] 12 HOUR

P1840 PGM **06-07**
Date Separator : [-]

3. Set separators for “DATE”, using ASCII code table on page

P1840 PGM 07-07
Time Separator : [:]

EX) Time Separator=[:]

☞ Please refer to “ASCII Code Table” (chapter 4.4) to input special characters in Date or Time separator.

4. Press “PRINT” key to save it and go out to SCALE CONFIGURATION main menu.

PRINT

P1800 PGM
Dept No. : [2] Grocery

2.10.6 User / Security Configuration (Menu code 1850)

(MENU → 8. Scale Config → 5. User/Sec Conf)

This section is to create, edit, change, list, delete clerk's security information and configure security level.

2.10.7 New/Edit User(Menu code 1851)

(MENU → 8. Scale Config → 5. User/Sec Conf → 1. New/Edit)

Enter appropriate USER data for CLERK number, CLERK NAME, NICKNAME, CLERK PASSWORD, CLERK LEVEL, and LABEL MESSAGE NO.

P1851 PGM 01-06
Clerk No. : [2]

EX) CLERK No.=[2],
CLERK NAME=[CHRISTOPER],
NICKNAME=[CHRIS],
CLERK PASSWORD=[0115],
CLERK LEVEL=[3],
Use for Training=[N]

P1851 PGM 02-06
Clerk Name : [CHRISTOPER]

P1851 PGM 03-06
Nickname : [CHRIS]

Note : If you use floating mode,
you have to register all clerks.

P1851 PGM 04-06
Clerk Password : [0115]

P1851 PGM 05-06
Clerk Level : [3]

P1851 PGM 06-06
Use for Training [N]

► NEW/EDIT USER in USER'S Security Condition

| No | Operation Modes | Description |
|----|------------------|--|
| 1 | Clerk No. | This value can be from 1 to 95. |
| 2 | Clerk Name | This value is available up to 22 characters. |
| 3 | Nickname | This value is available up to 7 characters. It can be printed on a label and displayed on the scale. |
| 4 | Clerk Password | 4 digit (alphanumeric) |
| 5 | Clerk Level | 0~3 level |
| 6 | Use for Training | Enter "Y" or "N" |

Password : When you enter the password, you have to type clerk number(2 digit) and password(4 digit). For example, if your clerk number is 20 and password is 1234, you have to type 201234. Minimum password is 3 digit and maximum password is 6 digit. If there is no level 3 clerk, you can use default value. (Clerk No:1, password:1, Level:3) Therefore default password is 011.

※ You have to set a level 3 clerk. If there is no level 3 clerk, you can use default password(011) and if any, you cannot use it.

Clerk level: This value can be from 0 to 3. This level is related to menu 1855(Config permission). If clerk 2 is set to level 2, this clerk can use the function which is set to level 1, 2 in menu 1855 and cannot use the function which is set to level 3.

| No. | Level | Description |
|-----|-------|---|
| 1 | 0 | It is assigned to employees who is registered but do not use scale. |
| 2 | 1 | Lowest level. Normal employees are assigned to level 1. |
| 3 | 2 | It is proper for chief clerk. |
| 4 | 3 | Highest level. It is proper for store manager. |

2.10.8 Change Password (Menu code 1852)

(MENU → 8. Scale Config → 5. User/Sec Conf → 2. Change Password)

1. Enter password.

* Clerk No. (2 digit)+ password (4 digit)

Input Password : []

EX) CLERK No.=1 , PASSWORD=2 -> 012
 CLERK No.=11 , PASSWORD=22 -> 1122
 CLERK No.=36 , PASSWORD=1234 -> 361234

2. New Password

* Enter new password

EX) PASSWORD = 22

P1852 PGM

01-01

New Password : [22]

2.10.9 List User (Menu code 1853)

(MENU → 8. SCALE CONFIG → 5. User/Sec Conf → 3. List)

1. Enter start number and end number to check

* To list all, press the SAVE key

EX) 1~95

1
YES PRINT

P1851 PGM

01-02

1st Number : [1]

9 5
WXYZ JKL PRINT

P1851 PGM

02-02

2nd Number : [95]

P1851 PGM

02-02

1 3 JOHNATHAN

2.10.10 Delete User (Menu code 1854)

(MENU → 8. SCALE CONFIG → 5. User/Sec Conf → 4. Delete)

1. Enter clerk number to delete

EX) Delete clerk no. 2

P1854 PGM

01-01

Clerk No. : [2] LEE

2.10.11 Config Permission (Menu code 1855)

(MENU → 8. SCALE CONFIG → 5. User/Sec Conf → 5. Config Permission)

Permission level is related to clerk level and if the clerk level is lower than permission level, this clerk cannot access that function. Refer to clerk level on chapter 2.14.21

※ If permission level is "0", all clerks can access this function.

EX) If you set permission level to 2 for price change key and clerk 1 is set to level 1 and clerk 2 is set to level 2, clerk 1 can not use this key but clerk 2 can use this key.

► Setting Configuration Permission

| No. | Operating | Description |
|-----|-------------------------|--|
| 1 | Use Item Change Key | Set a permission level for PLU Change Key. (You can define this function key in menu 1880 on chapter 2.14.22) |
| 2 | Use Price Change Key | Set a permission level for price change key. (You can define this function key in menu 1880 on chapter 2.14.22) |
| 3 | Use Dept. Change Key | Set a permission level for department change key. (You can define this function key in menu 1880 on chapter 2.14.22) |
| 4 | Use Pay Key | Set a permission level for Pay key (You can define this function key in menu 1880 on chapter 2.14.22) |
| 5 | Use Date Change Key | Set permission level for data change key. (You can define this function key in menu 1880 on chapter 2.14.22) |
| 6 | Use Type Change Key | Set a permission level for PLU type change key.(You can define this function key in menu 1880 on chapter 2.14.22) |
| 7 | Use selection PLU Item | Set a permission level for Selecting PLU item |
| 8 | Use Input Weight Key | Set a permission level for Input weight key(You can define this function key in menu 1880 on chapter 2.14.22) |
| 9 | Use Discount Key | Set a permission level for discount (You can define this function key in menu 1880 on chapter 2.14.22) |
| 10 | Allow Clerk Sale | Set a permission level for password in floating mode |
| 11 | Allow Void | Set a permission level to void item |
| 12 | Allow Add Up | Set a permission level for add-up sales |
| 13 | Allow Return | Set a permission level to return item |
| 14 | Allow Override | Set a permission level to override price |
| 15 | Allow CashDraw Open | Set a permission level to open cash drawer |
| 16 | Allow Menu | Set a permission level to go to program menu |
| 17 | Allow Menu for edit PLU | Set a permission level to edit PLU |
| 18 | Allow Price Change | Set a permission level to change price |
| 19 | Allow Global Set | Set a permission level for global setting |
| 20 | Allow X Report | Set a permission level for X report |
| 21 | Allow Z Report | Set a permission level for Zreport |
| 22 | Allow Store Data Edit | Set a permission level to edit store data |
| 23 | Allow Tax Edit | Set a permission level to edit tax |
| 24 | Allow Scale Config | Set a permission level for scale configuration |

| | | |
|----|-------------------------|---|
| 25 | Allow Communication Msg | Set a permission level for communication message |
| 26 | Allow Edit Data Table 1 | Set a permission level to edit data table I. |
| 27 | Allow Edit Data Table 2 | Set a permission level to edit data table II. |
| 28 | Allow Printer Setting | Set a permission level for printer setting |
| 29 | Allow Change Oper Mode | Set a permission level to change operation mode |
| 30 | Allow Change User Param | Set a permission level to change user param. |
| 31 | Allow Set Communication | Set a permission level for communication setting. |
| 32 | Use save key | Set a permission level for Save key |

You can use the PG UP and PG DOWN keys to navigate from page to page, or you can use the Arrow keys to go through each page 1 line at a time.

2.10.12 Clerk Key (Menu code 1856)

(MENU → 8. SCALE CONFIG → 5. User/Sec Conf → 6. Clerk Key)

You can assign Clerk key to clerk. There are 31 Clerk keys and you have to set these keys in menu 1880 (Key define). See chapter 2.14.22.

1. Enter Clerk Key

- This value can be from 1 to 31.

P1856 PGM

01-02

Clerk Key : [2]

EX) Clerk Key No. = 2

2. Enter Clerk No.

EX) Clerk = 2. LEE

P1856 PGM

02-02

Clerk No. : [2]

LEE

For example if you set "A" key to clerk 2 in menu 1880 (Key define), and call up a PLU and press "A" key in floating sale mode, it is recognized that clerk no. 2 (LEE) sold this item.

2.10.13 Test (Menu code 1860)

(MENU → 8. SCALE CONFIG → 6. Test)

This programming is to test the scale by itself in the 7 fields , such as DISPLAY, A/D, KEYBOARD, PRINTER, RINTER SENSOR, MEMORY INFORMATION AND FIRMWARE VERSION.

① Press "6" to get into TEST menu.

6
MNO

P1860 PGM

1.Display

>1/8

| No. | Item |
|-----|--------------------|
| 1 | Display |
| 2 | A/D |
| 3 | Keyboard |
| 4 | Chess Print |
| 5 | Printer Sensor |
| 6 | Memory Information |
| 7 | Firmware Version |
| 8 | Communication |

2.10.14 Display Test (Menu code 1861)

(MENU → 8. SCALE CONFIG → 6. Test → 1. Display)

To test the display, press “1” on Test menu screen. It automatically tests it. User may exit from testing, using “ESC” key.

2.10.15 A/D Test (Menu code 1862)

(MENU → 8. SCALE CONFIG → 6. Test → 2. A/D)

To test the A/D, press “2” on Test menu screen.

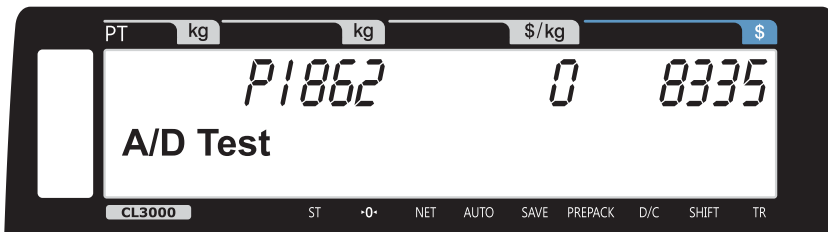

To set zero press “ZERO”



User may exit from this menu, using “ESC” key

2.10.16 Keyboard Test (Menu code 1863)

(MENU → 8. SCALE CONFIG → 6. Test → 3. Keyboard)

To test keyboard, press “3” on Test menu screen.

P1863 PGM
Keyboard Test

To exit keyboard test, press “ESC” two times.

2.10.17 Chess Printer Test (Menu code 1864)

(MENU → 8. SCALE CONFIG → 6. Test → 4. Chess Print)

Press “TEST” key to test printing a label.

P1864 PGM **01-01**
[TEST] = Print

User may exit from this menu, using “ESC” key.

2.10.18 Printer Sensor Test (Menu code 1865)

(MENU → 8. SCALE CONFIG → 6. Test → 5. Printer Sensor)

To test printer sensor, press “5” on Test menu screen. The scale shows the condition of current printer sensor.

P1865 PGM **01-02**
Peel[UNL] Head[CLS]

P1865 PGM **02-02**
Gap [68] Peel [66]

► Printer Sensor Test Items

| No | Test Items | Description |
|----|------------|--|
| 1 | Peel-off | To test that peel-off sensor is properly work. |
| 2 | Head-up | To test that TPH is opened or not |
| 3 | Gap | To show real time-sensing Gap value. |
| 4 | Peel | To show real time-sensing peel value. |

2.10.19 Memory Information (Menu code 1866)

(MENU → 8. SCALE CONFIG → 6. Test → 6. Memory Information)

To see memory information, press “6” on Test menu screen. The display shows current memory size. 0 indicates 1MB.

P1863 PGM
BNK0:4MB BNK1:4MB

User may exit from this menu, using “ESC” key.

2.10.20 Firmware Version (Menu code 1867)

(MENU → 8. SCALE CONFIG → 6. Test → 7. Firmware Version)

You can check firmware version of the scale.

P1867 PGM
MB:CL3-CHN-10.1.00r

User may exit from this menu, using “ESC” key.

2.10.21 Scale Parameter (Menu code 1870)

(MENU → 8. SCALE CONFIG → 7. Scale Parameter)

You can set scale’s environment as below.

► Scale Parameter

| Menu | Sub-menu | Setting Value | Description |
|-------------------------------------|-----------------------------|---|--|
| 1. Display (Menu code:1871) | Display Discount Info | Y/N | The scale shows discount information. |
| | Show Clerk Nickname | Y/N | The scale shows clerk’s nickname |
| | PLU Name Align | 0: Left alignment 1: Center alignment 2: Right alignment | Set the alignment position of PLU |
| | Enable scroll msg | Y/N | The scale shows scroll message |
| 2. Printing (Menu code:1872) | Label prt w/o rewind(x Key) | Y/N | Do not use rewind function when you use “X”key. |
| | Confirm prt report on label | 0:Print automatically 1:Need to confirm to print report and do not confirm any more until power off 2:Need to confirm to print report and do not confirm any more until you exit program mode | Set confirm method when you print report in label mode |

| | | | |
|---|---------------------------------|--|---|
| | Print origin for comm. line | 0: Do not print 1: Print in Name 1. 2: Print in Name 2 3: Print in Name 3 | Print origin in commodity line. |
| | Print unit symbol in qty area | Y/N | Print Qty Symbol in qty area. |
| | Print pieces in unit price area | Y/N | Print Pieces in unit price area. |
| | Print All report within range | Y/N | Print all report |
| | Swedish Auto Barcode | Y/N | Print Swedish Auto Barcode |
| | Print Prepack Type | Y/N | Print Prepack |
| | Print Item when return | Y/N | Print Item when return |
| 3. Sale Setup (Menu code:1873) | Save unit price change | Y/N | Save unit price change. |
| | Save Type change | Y/N | Save type Change in PLU |
| | Start save mode(start up) | Y/N | Save mode is active when you turn on the scale. |
| | PLU clr Aft sale(WT. On Tray) | Y/N | Plu is cleared after printing even though there is an item on the platter. |
| | Print count w.o misc. key | Y/N | If you enter count, it is considered that misc. count condition when there is no Misc. Key |
| | Print weight w.o misc. key | Y/N | If there is an item on the platter, it is considered that misc. weight condition when there is no Misc. Key |
| | T,price = price + Tax | Y/N | Tax is included in total price |
| | Shift key instead return Key | Y/N | Use shift key instead of return key. |
| | Use double speed key | Y/N | Use double speed key |
| | Use double Date/Time key | Y/N | ! |
| | Multi-print on discount sale | Y/N | Print some labels on discount sale |
| | Star auto mode(start up) | Y/N | Run Auto mode at Power On |
| | Enable Quick PLU | Y/N | Select PLU automatically when you type a PLU number |
| 4. Clerk Logout (Menu code:1874) | Log off after transaction | Y/N | After printing label, automatically Clerk Log off |
| | Clerk log out Time(0.1s) | 1~99 | Set clerk log out time. |

You can use the PG UP and PG DOWN keys to navigate from page to page, or you can use the Arrow keys to go through each page 1 line at a time.

2.10.22 Function Key Define (Menu code 1880)

(MENU → 8. Scale → 8. function Key Define)

You can define function keys to Speed keys. It is recommended that you define function key to higher number Speed key because you can not use that PLU key.

1. Enter key code

Pole type : 72 Speed Keys

Standard type : 48 Speed Keys.

If you press Speed key, the displays shows the key code of that speed key.



| | |
|------------------|--------------|
| P1880 PGM | 01-01 |
| Key [48] | F [0] |

EX) Standard Type :

Press last speed key.



| | |
|------------------|--------------|
| P1880 PGM | 01-01 |
| Key [72] | F [0] |

EX) Pole Type:

Press last speed key

2. Enter function key

EX) Use 12 Function key (LCD Back_light ON/OFF) Refer to below table.



| | |
|------------------|--------------|
| P1880 PGM | 01-01 |
| Key [48] | F [12] |

► Function Key.

| Function Key | Define | Description |
|--------------|------------------|--------------------------|
| 1 | [DISC -] | - SALE Key |
| 2 | [DISC%] | % SALE Key |
| 3 | [SPECIAL SALE] | Special sales unit price |
| 4 | [NEGATIVE] | Negative sale |
| 5 | [FIXED PRICE] | Fixed Price Key |
| 6 | [TYPE CHANGE] | WT/CT Key |
| 7 | [CASHOPEN] | Cash Drawer Open Key |
| 8 | [GRAND TOTAL] | Grand Total Key |
| 9 | [PLU REFERENCE] | Reference PLU Key |
| 10 | [IN WEIGHT] | In-Weight Key |

| | | |
|-----------|-----------------|---|
| 11 | [LABEL/TICKET] | Toggle between the Label and Ticket |
| 12 | [LEDON] | LCD Backlight On/Off Key |
| 13 | [MISC WEIGHT] | Misc. Weight Key |
| 14 | [MISC COUNT] | Misc. Count Key |
| 15 | [MISC PCS] | Misc. PCS Key |
| 16 | [EDIT SELL] | Sell By Date Change Key |
| 17 | [EDIT ORIGIN] | Origin Change Key. |
| 18 | [EDIT ITEM] | PLU Change Key |
| 19 | [EDIT DATETIME] | Change Date/Time |
| 20 | [EDIT D/C] | Set discount for current PLU |
| 21 | [EDIT SPEEDKEY] | Change PLU Speed key |
| 22 | [EDIT PRICE] | PLU Price Change Key |
| 23 | [CLERK CALL] | Clerk key to call indirectly |
| 24 | [LAST VOID] | Void Last Sale |
| 25 | [OVERRIDE] | Override key |
| 26 | [DEPT] | Department Key |
| 27~30 | [CURRENCY1~4] | Call Currency Table |
| 33~41 | [TARE KEY1~9] | Call Tare Table |
| 42~44 | [UNIT1~3] | kg : UNIT1=1kg, UNIT2=100g, UNIT3=N/A lb : UNIT1=1lb, UNIT2=1/2lb, UNIT3=1/4lb |
| 45 | [kg/lb] | Toggle between the kg and lb |
| 53~84 | [V1~32] | Clerk key |
| 0 or 9999 | | PLU Key |

3. To cancel function key.

Enter key code to cancel and set Function Key No. to 0

P1880 PGM
Key [42]

01-01
F [0]

EX) Key Code = 42
Function Key id = 0

If you cancel function key, you can use it as Speed key.

2.11 Report

2.11.1 Introduction

X mode is used to read (i.e. print and display) sales data. There are variety of reports that you can generate from X mode. Each of these reports is kept in two separate counters or “books” called X1 and X2. The X1 and X2 reports allow you to print reports at any time for either of the reporting periods. You can use X1 reports to see current daily totals and X2 reports to see current weekly totals. The time period combination you chose is completely dependent upon how you use Z1 and Z2.

Remember that you can generate as many X reports as you would like because X mode does NOT clear any sales data.

2.11.2 Report Menu (Menu code 1600)

(MENU → 6. Report)

| | |
|---------------------------------------|---------------------------------------|
| P1600 PGM 1. X1 Report >1/5 | P1600 PGM 4. Z2 Report >4/5 |
| P1600 PGM 2. Z1 Report >2/5 | P1600 PGM 5. Clear All >5/5 |
| P1600 PGM 3. X2 Report >3/5 | |

| No. | Submenus | Description |
|-----|-----------|---|
| 1 | X1 Report | Print and display sales data of period 1 |
| 2 | Z1 Report | Print, display and clear sales data of period 1 |
| 3 | X2 Report | Print and display sales data of period 2 |
| 4 | Z2 Report | Print, display and clear sales data of period 2 |
| 5 | Clear All | Clear all reports of period 1 and 2 |

2.11.3 X1/X2 Report (Menu code 1610/1630)

(MENU → 6. Report → 1. X1 Report / → 3. X2 Report)

There are 7 detailed reports.

P1610 PGM
1. Scale >1/7

| No | Submenus | Description |
|----|------------|---|
| 1 | Scale | Print and display scale sales report |
| 2 | PLU | Print and display PLU sales report |
| 3 | Misc. PLU | Print and display Misc. PLU sales report |
| 4 | Group | Print and display group sales report |
| 5 | Department | Print and display department sales report |
| 6 | Hourly | Print and display hourly sales report |
| 7 | Clerk | Print and display clerk sales report |

2.11.4 X1/X2 Scale Sales Report (Menu code 1611/1613)

(MENU → 6. Report → 1. X1 Report /3. X2. Report → 1. Scale)

If you press "1" key on X1/X2 Report menu screen, scale sales report is shown on the display.



P1611 PGM **01-01**
TotalUSD 202.28 CNT11

To print this report, press "TEST" key.



To exit this menu, press the "ESC" key.



P1610 PGM
1. Scale >1/7

► Sample - Scale Report

| | | |
|----------------------------|----|------------|
| X 1 S C A L E R E P O R T | | |
| AUG-23-04(MON) 09:46:36 AM | | |
| Last Reset | | |
| AUG-16-04(MON) 03:33:14 PM | | |
| ===== | | |
| SCALE #01 | | |
| ----- | | |
| TOTAL COUNT | | 267 |
| TOTAL PRICE | \$ | 5693.70 |
| VOID COUNT | | 3 |
| VOID PRICE | \$ | 27.30 |
| REPACK COUNT | | 0 |
| REPACK PRICE | \$ | 0.00 |
| OVERRIDE COUNT | | 0 |
| OVERRIDE PRICE | \$ | 0.00 |
| DISCOUNT COUNT | | 0 |
| DISCOUNT PRICE | \$ | 0.00 |
| PREPACK COUNT | | 1 |
| PREPACK PRICE | \$ | 3.05 |
| RETURN COUNT | | 0 |
| RETURN PRICE | \$ | 0.00 |
| NO SALE OPEN COUNT | | 0 |
| PAY SUMMARY | | |
| CASH | 26 | \$ 1242.70 |
| PIN/CHIP | 2 | \$ 12.50 |
| CHECK | 2 | \$ 82.00 |
| CREDIT CARD | 5 | \$ 84.40 |
| CREDIT NOTE | 2 | \$ 61.00 |
| COUPON | 3 | \$ 17.00 |
| BONUS POINT | 0 | \$ 0.00 |
| CREDIT SALES | 3 | \$ 60.00 |
| CHANGE | 17 | \$ 287.46 |
| TAX SUMMARY | | |
| 1:10.00%, Internal | | \$ 67.39 |
| 2:10.00%, External | | \$ 242.00 |
| 3: 8.00%, Internal | | \$ 190.95 |
| 4: 0.00% | | \$ 0.00 |
| 5: 0.00% | | \$ 0.00 |
| 6: 0.00% | | \$ 0.00 |
| 7: 0.00% | | \$ 0.00 |
| 8: 0.00% | | \$ 0.00 |
| 9: 0.00% | | \$ 0.00 |
| ----- | | |
| ===== | | |

2.11.5 X1/X2 PLU Report (Menu code 1612/1632)

(MENU → 6. Report → 1. X1 Report /3. X2 Report → 2. PLU Report)

Press "2" key on X1/X2 Report menu screen.

2
ABC

P1612 PGM 01-03
Dept No.[1]

Enter PLU range to check.

EX) dept 1, plu 1 ~10

1 PRINT 1 PRINT 1 0
YES YES YES NO

P1612 PGM 01-03
PLU No.[1]
PLU[1]..to[10]

P1612 PGM 01-03
..to[10]

PLU sales report is shown on the display by pressing "PRINT" key.

PRINT

P1612 PGM 03-03
TotaUSD 4867.23 CN:261

To print report, press "TEST" key.

PAY
TEST

To exit this menu, press "ESC" key.

MENU
ESC

P1610 PGM
1. Scale >1/7

Note: PLU with no sales is not printed.

► Sample - PLU Report

```
X 1 P L U R E P O R T
AUG-23-04(MON) 09:46:36 AM
Last Reset
AUG-16-04(MON) 03:33:14 PM
Start No:00000, End No:99999
=====
DEPT #01 Default
=====
PLU #00001 APPLE
TRANSACTION COUNT          84
WEIGHT                    74.828 kg
QUANTITY                   0
PRICE                     $ 681.79
TAX PRICE                  $ 67.39

PLU #00002 BANANA
TRANSACTION COUNT          96
WEIGHT                    0.000 kg
QUANTITY                   98
PRICE                     $ 1994.00
TAX PRICE                  $ 196.00

PLU #00003 ORANGE
TRANSACTION COUNT          61
WEIGHT                    0.000 kg
QUANTITY                   62
PRICE                     $ 1994.00
TAX PRICE                  $ 196.00

. . .
=====
=====
```

2.11.6 X1/X2 Miscellaneous PLU Report (Menu code 1613/1633)

(MENU → 6. Report → 1. X1 Report /3. Report → 3. MISC. PLU)

Press “3” key on X1/X2 Report menu screen.

3
DEF

P1613 PGM

01-01

Misc(0-2)[0]..to[2]

Enter the number to check.

0 : Miscellaneous by-Weight

1 : Miscellaneous by-count

2 : Miscellaneous by-pcs

0
NO

PRINT

2
ABC

P1613 PGM

01-01

Misc(0-2)[0]..to[2]

Ex) Misc. by-weight, Misc. by-count, Misc. by-pcs

Sales report is shown on the display by pressing “PRINT” key.

PRINT

P1613 PGM

01-01

TotalUSD 4867.23

CN:41

To print report, press “TEST” key.

PAY
TEST

To exit this menu, press “ESC” key.

MENU
ESC

P1610 PGM

1. Scale

>1/7

Note: Misc. PLU with no sales is not printed.

► Sample - Miscellaneous Report

X 1 M I S C . R E P O R T
AUG-23-04(MON) 09:46:36 AM
Last Reset
AUG-16-04(MON) 03:33:14 PM
Start No:0, End No:2

=====

| PLU # | Misc By Weight | |
|-------------------|----------------|----|
| TRANSACTION COUNT | | 84 |
| WEIGHT | 74.828 kg | |
| QUANTITY | | 0 |
| PRICE | \$ 681.79 | |
| TAX PRICE | \$ 67.39 | |

=====

| PLU # | Misc by Count | |
|-------------------|---------------|----|
| TRANSACTION COUNT | | 96 |
| WEIGHT | 0.000 kg | |
| QUANTITY | | 98 |
| PRICE | \$ 1994.00 | |
| TAX PRICE | \$ 196.00 | |

=====

| PLU # | Misc By PCS | |
|-------------------|-------------|----|
| TRANSACTION COUNT | | 61 |
| WEIGHT | 0.000 kg | |
| QUANTITY | | 98 |
| PRICE | \$ 1994.00 | |
| TAX PRICE | \$ 196.00 | |

=====

2.11.7 X1/X2 Group Report (Menu code 1614/1644)

(MENU → 6. Report → 1. X1 Report /X2. Report → 4. Group)

Press "4" key on X1/X2 Report menu screen.

4
GHI

P1614 PGM

01-01

No. from[0]..to[0]

Enter group range to check
If you do not set group in PLU creating,
it is included group 0.

1
YES

PRINT

2
ABC

3
DEF

P1614 PGM

01-01

No. from[1]..to[23]

EX) Group 0 ~ Group 23

You can see group sales data by pressing
"PRINT" key.

PRINT

P1614 PGM

01-01

TotalUSD 4867.23

CNT261

To print report, press "TEST" key.

PAY
TEST

P1614 PGM

01-01

TotalUSD 4867.23

CNT261

To exit this menu, press "ESC" key.

MENU
ESC

P1610 PGM

1. Scale

>1/7

Note: If the setting of MENU 1862, "Print All Report within Range" is "No", the group with no sales is not printed. But if "Yes", all group sales data within the range is printed.

► Sample - Group Report

| | |
|---------------------------------|-----------|
| X 1 G R O U P R E P O R T | |
| AUG-23-04(MON) 09:46:36 AM | |
| Last Reset | |
| AUG-16-04(MON) 03:33:14 PM | |
| Start No:00, End No:99 | |
| ===== | |
| GROUP #00 NO Assigned PLU Group | |
| ----- | |
| TOTAL COUNT | 276 |
| TOTAL PRICE | \$5993.70 |
| PREPACK COUNT | 1 |
| PREPACK PRICE | \$ 3.05 |
| ----- | |
| GROUP #01 Vegetable | |
| ----- | |
| TOTAL COUNT | 276 |
| TOTAL PRICE | \$5993.70 |
| PREPACK COUNT | 1 |
| PREPACK PRICE | \$ 3.05 |
| ----- | |
| GROUP #02 Fruit | |
| ----- | |
| TOTAL COUNT | 276 |
| TOTAL PRICE | \$5993.70 |
| PREPACK COUNT | 1 |
| PREPACK PRICE | \$ 3.05 |
| ----- | |
| . . . | |
| ===== | |

2.11.8 X1/X2 Department Sales Report (Menu code 1615/1635)

(MENU → 6. Report → 1. X1 Report /3.X2 Report → 5. Department)

Press "5" key on X1/X2 Report menu screen.

5
JKL

P1615 PGM

01-01

No. from[1]..to[1]

Enter department range to check.

1
YES

PRINT

1
YES

0
NO

EX) dept 1 ~ dept 10

P1615 PGM

01-01

No. from[1]..to[10]

You can see department sales data by pressing "PRINT" key.

PRINT

P1615 PGM

01-01

TotalUSD 4867.23

CNT261

To print report, press "TEST" key.

PAY
TEST

P1615 PGM

01-01

TotalUSD 4867.23

CNT261

To exit this menu, press "ESC" key.

MENU
ESC

P1610 PGM

1. Scale

>1/7

Note: If the setting of MENU 1862, "Print All Report within Range" is "No", the department with no sales is not printed. But if "Yes", all group sales data within the range is printed.

► Sample - Department Report

| | |
|-------------------------------------|-----------|
| X 1 D E P A R T M E N T R E P O R T | |
| AUG-23-04(MON) 09:46:36 AM | |
| Last Reset | |
| AUG-16-04(MON) 03:33:14 PM | |
| Start No:01, End No:99 | |
| ===== | |
| DEPT #01 Default | |
| ----- | |
| TOTAL COUNT | 274 |
| TOTAL PRICE | \$5993.70 |
| PREPACK COUNT | 1 |
| PREPACK PRICE | \$ 3.05 |
| RETURN COUNT | 0 |
| RETURN PRICE | \$ 0.00 |
| ----- | |
| DEPT #02 MEET | |
| ----- | |
| TOTAL COUNT | 274 |
| TOTAL PRICE | \$5993.70 |
| PREPACK COUNT | 1 |
| PREPACK PRICE | \$ 3.05 |
| RETURN COUNT | 0 |
| RETURN PRICE | \$ 0.00 |
| ----- | |
| DEPT #03 FISH | |
| ----- | |
| TOTAL COUNT | 274 |
| TOTAL PRICE | \$5993.70 |
| PREPACK COUNT | 1 |
| PREPACK PRICE | \$ 3.05 |
| RETURN COUNT | 0 |
| RETURN PRICE | \$ 0.00 |
| ----- | |
| . . . | |
| ===== | |

2.11.9 X1/X2 Hourly Sales Report (Menu code 1616/1636)

(MENU → 6. Report → 1. X1 Report /3.X2 Report → 6. Hourly)

Press “6” key on X1/X2 Report menu screen.

6
MNO

P1616 PGM 01-01
No. from[1]..to[23]

Enter time to check.

9 WXYZ PRINT 1 YES 4 GHI

EX)AM 9 hour ~ PM 2 hour

P1616 PGM 01-01
No. from[9]..to[14]

You can see hourly sales data by pressing
“PRINT” key.

PRINT

P1616 PGM 01-01
TotalUSD 4867.23 CNT261

To print report, press “TEST” key.

PAY
TEST

P1616 PGM 01-01
TotalUSD 4867.23 CNT261

To exit this menu, press “ESC” key.

MENU
ESC

P1610 PGM
1. Scale >1/7

Note: If the setting of MENU 1862, “Print All Report within Range” is “No”, the hour with no sales is not printed. But if “Yes”, all group sales data within the range is printed.

► Sample - hourly Report

X 1 H O U R L Y R E P O R T
AUG-23-04(MON) 09:46:36 AM
Last Reset
AUG-16-04(MON) 03:33:14 PM
Start No:00, End No:23

=====

HOUR #10

TOTAL COUNT 274
TOTAL PRICE \$5993.70

PREPACK COUNT 1
PREPACK PRICE \$ 3.05

HOUR #11

TOTAL COUNT 274
TOTAL PRICE \$5993.70

PREPACK COUNT 1
PREPACK PRICE \$ 3.05

HOUR #13

TOTAL COUNT 274
TOTAL PRICE \$5993.70

PREPACK COUNT 1
PREPACK PRICE \$ 3.05

. . .

=====

2.11.10 X1/X2 Clerk Sales Report (Menu code 1617/1637)

(MENU → 6. Report → 1. X1 Report /3.X2 Report → 7. Clerk)

Press “7” key on X1/X2 Report menu screen.

7
PQRS

P1617 PGM

01-01

No. from[0]..to[0]

Enter clerk range to check.

0
NO

PRINT

9
WXYZ

9
WXYZ

EX) clerk 0 ~ clerk 99

P1617 PGM

01-01

No. from[0]..to[99]

You can see clerk sales data by pressing
“PRINT” key.

PRINT

P1617 PGM

01-01

TotalUSD 4867.23

CNT261

To print report, press “TEST” key.

PAY
TEST

P1617 PGM

01-01

TotalUSD 4867.23

CNT261

To exit this menu, press “ESC” key.

MENU
ESC

P1610 PGM

1. Scale

>1/7

Note: If the setting of MENU 1862, “Print All Report within Range” is “No”, the clerk with no sales is not printed. But if “Yes”, all group sales data within the range is printed.

► Sample - Clerk Report

| | | |
|----------------------------|------------|------------|
| X 1 C L E R K R E P O R T | | |
| AUG-23-04(MON) 09:46:36 AM | | |
| Last Reset | | |
| AUG-16-04(MON) 03:33:14 PM | | |
| Start No:00, End No:99 | | |
| ===== | | |
| CLERK #00 MANAGER | | |
| ----- | | |
| TOTAL COUNT | 267 | |
| TOTAL PRICE | \$ 5693.70 | |
| VOID COUNT | 3 | |
| VOID PRICE | \$ 27.30 | |
| REPACK COUNT | 0 | |
| REPACK PRICE | \$ 0.00 | |
| OVERRIDE COUNT | 0 | |
| OVERRIDE PRICE | \$ 0.00 | |
| DISCOUNT COUNT | 0 | |
| DISCOUNT PRICE | \$ 0.00 | |
| PREPACK COUNT | 1 | |
| PREPACK PRICE | \$ 3.05 | |
| RETURN COUNT | 0 | |
| RETURN PRICE | \$ 0.00 | |
| NEGATIVE COUNT | 0 | |
| NEGATIVE PRICE | \$ 0.00 | |
| NO SALE OPEN COUNT | 0 | |
| PAY SUMMARY | | |
| CASH | 26 | \$ 1242.70 |
| PIN/CHIP | 2 | \$ 12.50 |
| CHECK | 2 | \$ 82.00 |
| CREDIT CARD | 5 | \$ 84.40 |
| CREDIT NOTE | 2 | \$ 61.00 |
| COUPON | 3 | \$ 17.00 |
| BONUS POINT | 0 | \$ 0.00 |
| CREDIT SALES | 3 | \$ 60.00 |
| CHANGE | 17 | \$ 287.46 |
| ----- | | |
| CLERK #01 CLERK | | |
| ----- | | |
| TOTAL COUNT | 267 | |
| TOTAL PRICE | \$ 5693.70 | |
| | | |
| ----- | | |
| CLERK #02 AHN | | |
| ----- | | |
| TOTAL COUNT | 267 | |
| TOTAL PRICE | \$ 5693.70 | |
| | | |
| ----- | | |
| ===== | | |

2.11.11 Z1/Z2 Report (Menu code 1620/1640)

(MENU → 6. Report → 2. Z1 Report / 4. Z2 Report)

If you select menu code 1620, you will see following screen.

| | |
|------------------|--------------|
| P1621 PGM | 01-01 |
| TotalUSD 6429.48 | CNT296 |

If you want to print and clear the data, press TEST key. The scale shows following screen.

| | |
|------------------|--------------|
| P1621 PGM | 01-01 |
| Sure?[N] | CNT296 |

To print and clear, press "1" key. The scale shows following screen.

1
YES

| | |
|------------------|--------------|
| P1621 PGM | 01-01 |
| Sure?[Y] | CNT296 |

When printing is done, Z1 data is cleared and exit this menu.
Sales data is same with X1 report

| | |
|------------------|--------------|
| P1621 PGM | 01-01 |
| Clear PLU Report | CNT296 |

| | |
|------------------|--------------|
| P1621 PGM | 01-01 |
| Clear Sub Report | CNT296 |

Note 1: If the setting of PARAMETER 598, "Print when Z Report clear" is "No", you cannot print Z Report.

| | |
|------------------|------|
| P1620 PGM | |
| 1. Scale | >1/7 |

Note 2: If the setting of PARAMETER 595 "Individual clear(Z report)" is "Yes", you can clear Scale, PLU, Misc. PLU, Group, Department, Hourly, Clerk data is cleared separately. But if you use this function, each report is not same with scale report.

2.11.12 Clear All Report (Menu code 1650)

(MENU → 6. Report → 5. Clear All)

If you select menu code 1650, you will see following screen.

P1650 PGM 01-01
Sure?[N]

To clear all report, press 1 key. If you do not want to clear, press 0 or ESC key.

1
YES

P1600 PGM
1. X1 report >1/5

3. SALES OPERATION

3.1 Basic Operation

This chapter explains basic operation of scale, such as how to set zero, tare, call up a PLU and override unit price in CL3000 series. In order to make sales transaction user should access REGISTRATION mode.

■ How to access REGISTRATION MODE: Turn ON the scale.

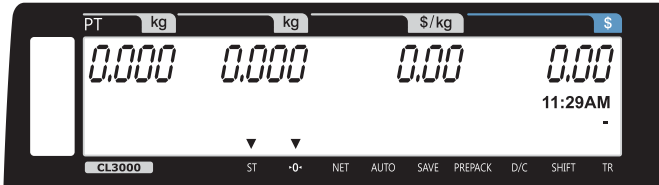

3.2 Zero

You can use the ZERO key to correct for a deviation from zero as long as there are no PLUs or MISC PLUs called-up. The weight can sometimes drift from zero due to debris on the platter, leaving objects on the platter for excessive periods of time, or other environmental factors. To correct this, remove everything from the platter and press the ZERO key when the stable indicator “▼” is on. Below is a possible zero drifted state that should be corrected by simply pressing the ZERO key.

① EX) Initial weight displayed → 0.002.

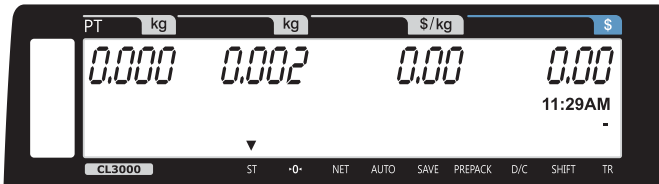

② Press “ZERO” key to set initial zero.

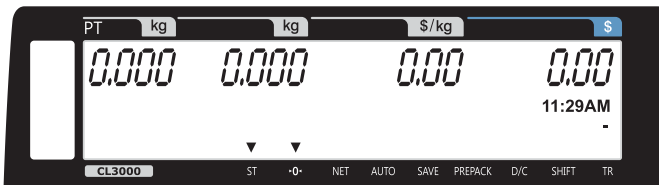

3.3 Tare

You can enter tare weights as long as there are no PLUs or MISC PLUs called-up. If you need to temporarily override a PLU's tare weight, you must enter the tare weight first and then call-up that PLU. There are two ways to enter a tare weight and both ways will only work if there is no PLU or MISC PLU called-up.

3.3.1 Manual Tare Entry 1

- ① Enter a tare weight manually by pressing the numeric keys
EX) 150 g

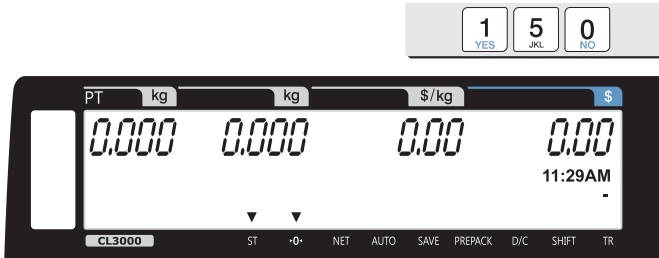

- ② Press "TARE" key.

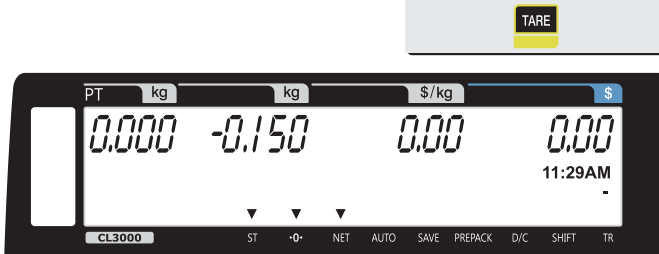

3.3.2 Weighed Tare Entry

- ① Place the empty container on the platter making sure that the weight is stable
EX) 0.15 kg

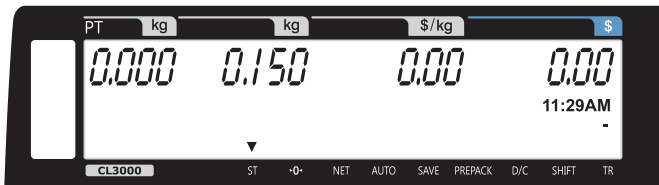

② Press “TARE” key.

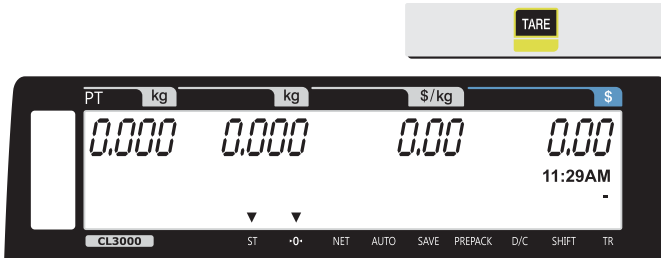

3.3.3 How to Clear Tare

① Remove the item from the platter

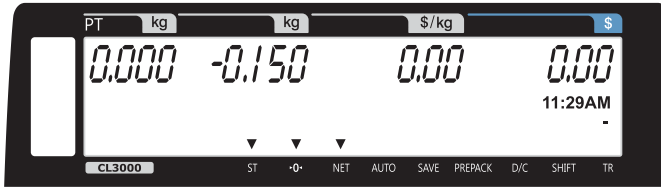

② Press “TARE” key again.

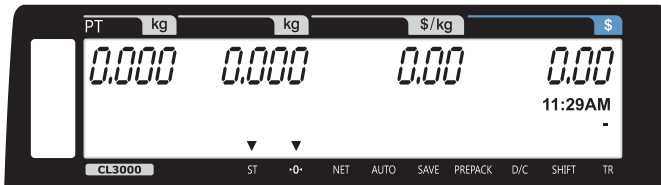

3.3.4 Preset Tare

① Call up a PLU including tare (weight of container).

EX) PLU #3's tare =150 g

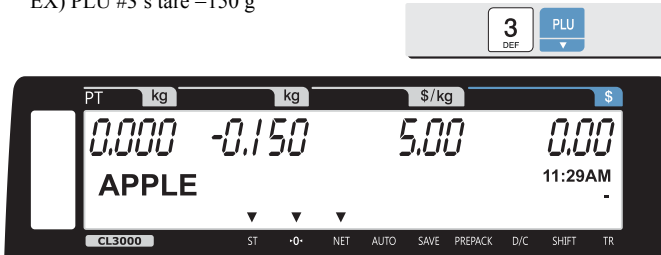

- ② Clear PLU#3, then tare is also automatically cleared.

3.3.5 Successive Tare

- ① Enter tare (weight of container) using numeric keys.
EX) 150 g

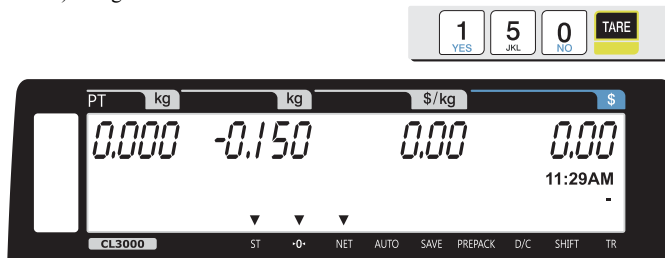

- ② Enter the weight of container using numeric keys.
EX) 200 g

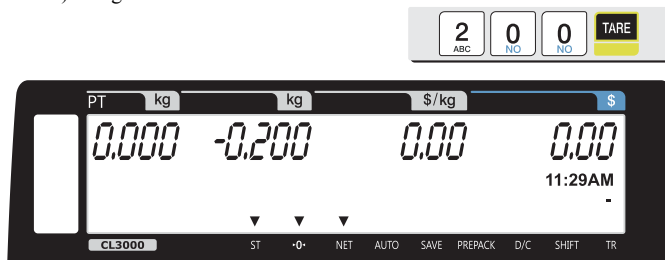

- ③ Press “TARE” key after removing item and container from the platter.

Note: Parameter 605 “Accumulation Tare” and parameter 606 “Subtraction Tare” must be set.

3.3.6 Tare Override

- ① Call up a PLU including tare (weight of container).
EX) PLU #4’s tare = 100 g

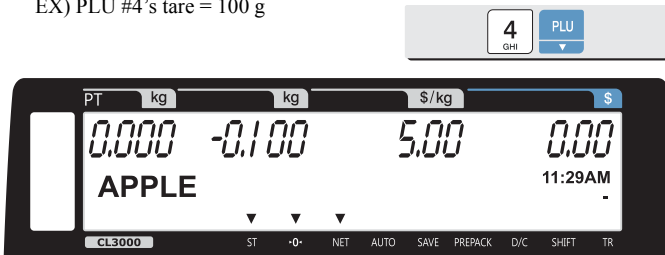

- ② Place the container (Weight of container must be greater than weight data input) for TARE OVERRIDE.

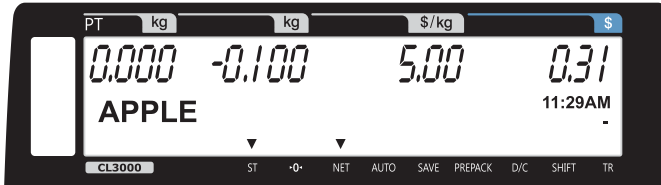

- ③ Pressing “TARE” key overrides current PLU tare (weight of container) and the weight becomes “0”.

Note: Parameter “603 PLU Tare Override” must be set.

To use OVERRIDE key, you have to set this key in menu 1880 of program mode.
(See chapter 2.10.22)

3.4 Calling Up a PLU

There are two ways to call up a PLU by using numeric key and preset key.

3.4.1 Using Numeric Key

- ① Enter PLU number by using numeric keys and press “PLU” key.
EX) PLU No. 15

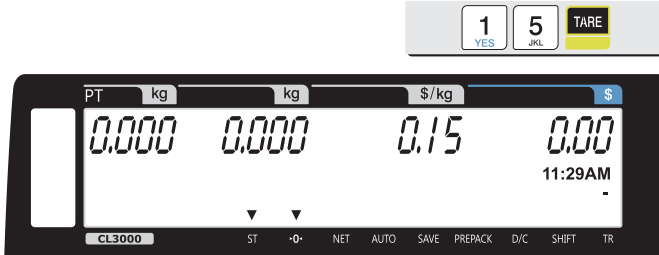

Note: Even though you do not press PLU key after entering a PLU number, PLU will be displayed depending on the setting time. It takes time to call up a PLU depending on the setting of parameter, 586 “Indirect PLU Call Time”..

3.4.2 Using Speed Key

To call-up PLU number 79, and you programmed Speed key #5 to be PLU number 79, then you need to press the following key: Speed key #5.

Note: You have to set Speed key in program mode (Menu 1160 on chapter 2.6)

- ① Press a speed key (which is save as a PLU).
EX) PLU #79=Apple, Speed key #5

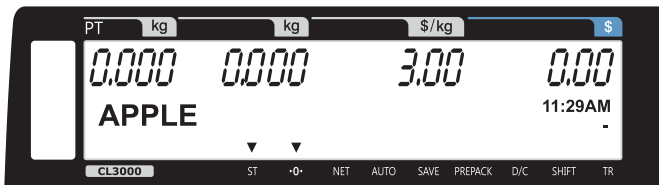

3.5 Override (FOR key)

The OVERRIDE key is used to temporarily change the pricing of priced PLUs.

- ☞ If you set program menu 1873(Save unit price change), changed priced is saved after printing a label.
- ☞ If Para 534 : Default UnitWeight is different from unit weight of PLU, "Multiple Unit PLU" message can be occurred.

3.5.1 By-Weight PLU

- PLU# 1.MEAT (PLU Type : By weight, Unit Price : 1.99\$).

- ① Press OVERRIDE key.

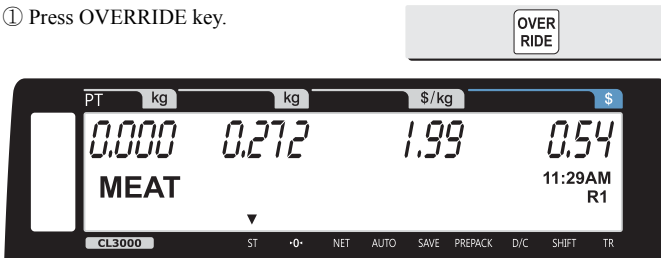

- ② Enter new unit price.

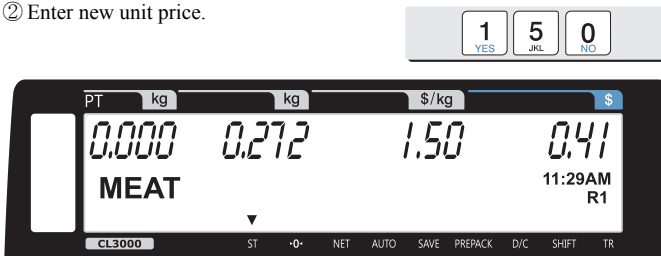

- ③ Press PRINT key to print label.

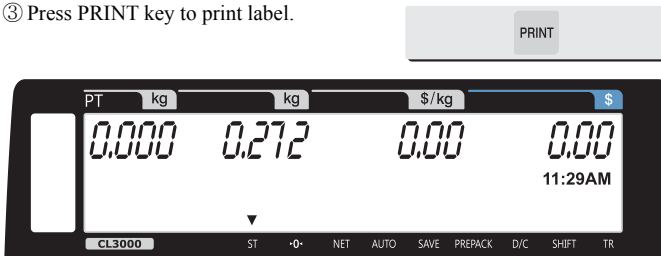

Note: To use OVERRIDE key, you have to set this key in menu 1880 of program mode.
(See chapter 2.10.22)

3.5.2 By-Count PLU

- PLU# 2.APPLE (PLU Type : By count, Unit Price : 1.00\$).

① Press OVERRIDE key.

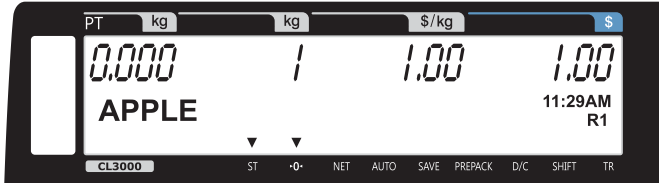

② Enter QUANTITY and press FOR key.

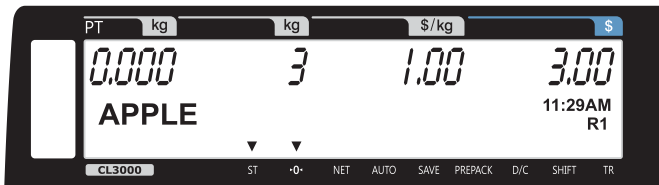

③ Enter new unit price.

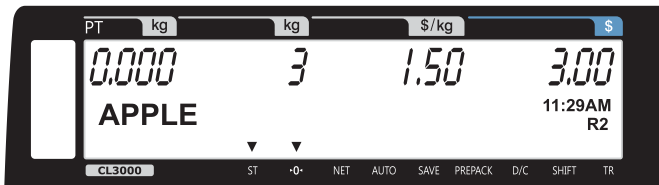

④ Press PRINT key to print label.

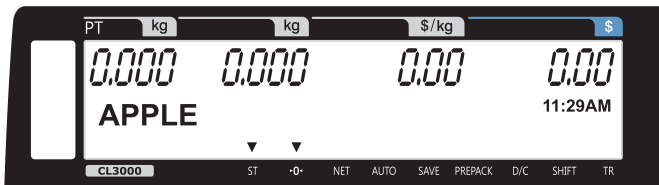

3.5.3 By-PCS PLU

- PLU# 3.Eggs (PLU Type : By PCS, Pieces : 3, Unit Price : 30.00\$).

① Press OVERRIDE key.

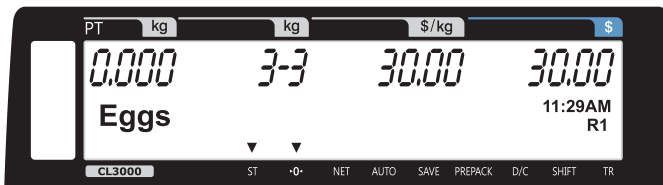

② Enter QUANTITY and press FOR key.

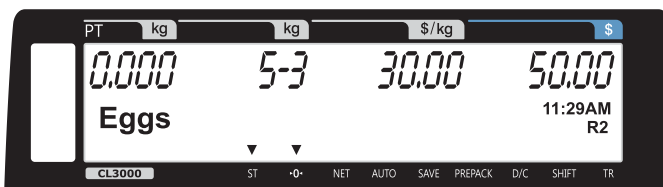

③ Enter PIECES and press FOR key

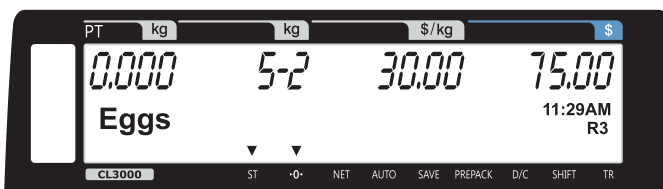

④ Enter new unit price.

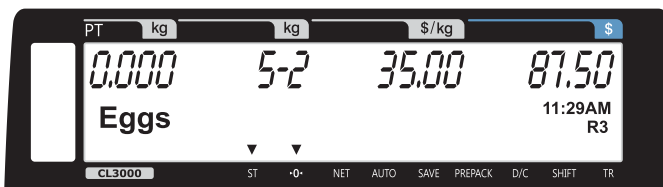

⑤ Press PRINT key to print label.

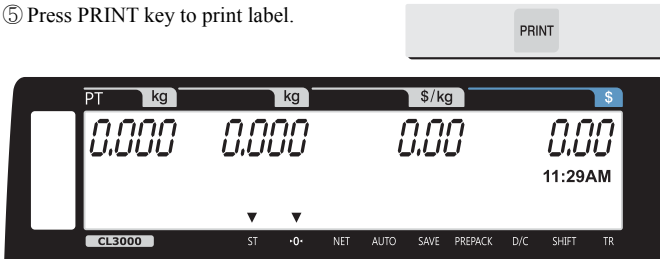

Note: - If you set program menu 1873(Save unit price change), changed priced is saved after printing a label.

- If you set parameter 501(Ride Second Position), you can change unit price of by-count PLU and pcs of by-pcs PLU directly.
- Discount function is not available when you use OVERRIDE key.

3.6 Sales Operation

3.6.1 Weighed Item Operation

EXAMPLE:

- PLU No : 29, PLU Name: ONION, PLU type : by weight, Unit Price : 1.50\$,
- Sales Weight =1.0kg

① Press Speed key to call up a PLU.

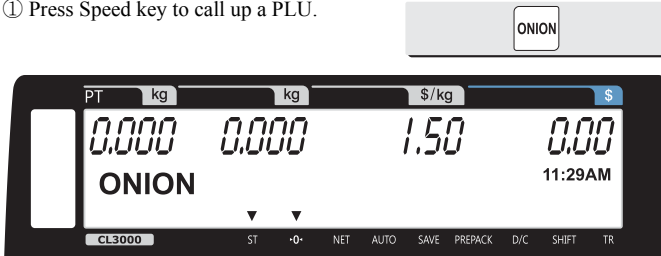

◆ User may call up a PLU by pressing speed key or numeric key. Please refer to chapter 3.4 for details..

② Place the item(s) on the platter.

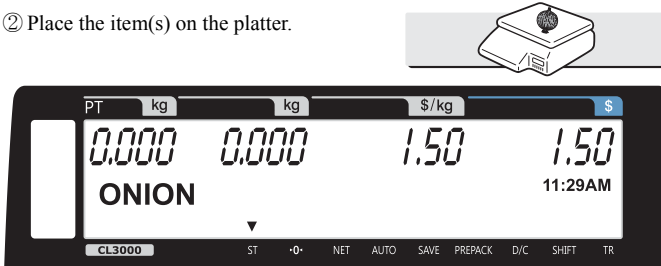

③ Press "PRINT" key to print a label and complete current transaction. This transaction(s) is saved in the sales record.

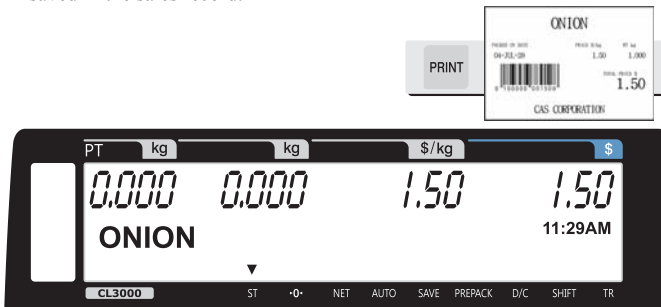

- ④ Remove the item(s) from the platter.

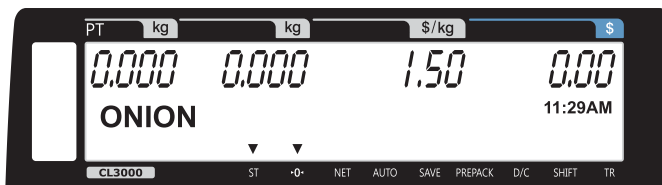

* Total Price= Sales weight X Unit price

Note: - In "SAVE" & "Prepack" mode the PLU is not automatically cleared when you remove the item from the platter.

- If you set "PLU clr Aft sale(WT.OnTray)" to "Y" in Menu 1873, PLU is cleared even though you do not remove the item from the platter. (See chapter 2.10.21 for menu 1873)

3.6.2 By Count Item

EXAMPLE:

- PLU No : 31, PLU Name: MANGO, PLU type = By-Count, Unit Price: 1.99\$,
- Sales 20 pieces.

- ① Press numeric key(s) to call up a PLU.

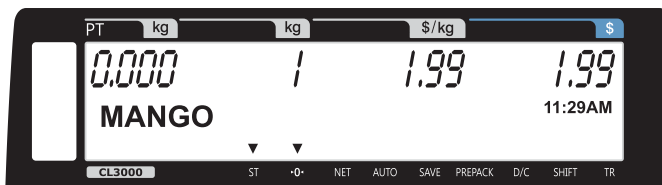

- ◆ User may call up a PLU by pressing speed key or numeric key. Please refer to chapter 3.4 for details.

- ② Enter the number of pieces.
EX) 20 pieces.

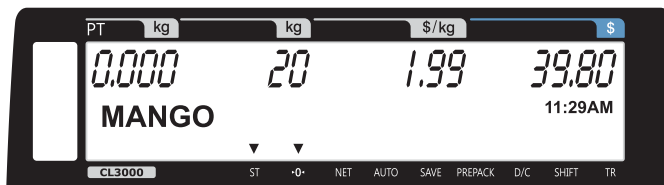

- ③ Press “PRINT” key to print a label and complete current transaction. This transaction(s) is saved in the sales record.



* Total Price= Piece(s) X Unit price

Note: In “SAVE” & “Prepack” mode, the PLU called up is not automatically cleared when you remove the item from the platter.

3.6.3 By PCS Item

EXAMPLE:

- PLU No : 30, PLU Name: ORANGE, PLU type = By PCS, PIECES: 5,
- Unit Price : 1.99\$
- Sales = 20 pieces. [QUANTITY item]

- ① Press numeric key(s) to call up a PLU.

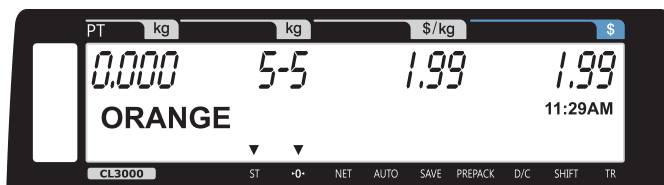

- ◆ User may call up a PLU by pressing speed key or numeric key. Please refer to page 143 for details.

- ② Enter QUANTITY [the number of Pieces].
EX) 20 pieces.

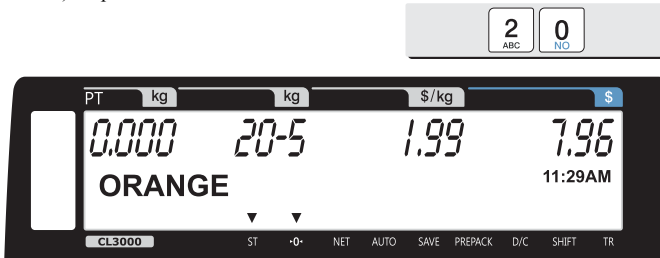

- ③ Press “PRINT” key to print a label and complete current transaction. This transaction(s) is saved in the sales record.



* Total Price= QUANTITY X [Unit price / PIECES]

Note: In “SAVE” & “Prepack” mode the PLU is not automatically cleared when you remove the item from the platter.

3.7 Discount

Before using discount function, you have to set discount data in menu 1130 of program mode. Discount is different depending on PLU type. (For details, see chapter 2.4.1)

3.7.1 Unit Price Discount - By Weight PLU

EXAMPLE:

- PLU# 29=Water Melon (By-Weight PLU), Unit price=20.00

- 1st Target of Discount : "Discount amount from unit price"=0.50 for weight \geq 0.500.
- 2nd Target of Discount : "Discount amount from unit price"=1.00 for weight \geq 1.000.

① Call up a PLU.

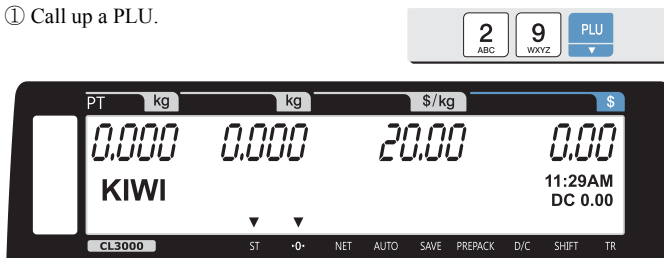

② Place an item on the platter. In this case, discount is not available because the weight of this item(0.489 kg) is lower than 1st target(0.500 kg).

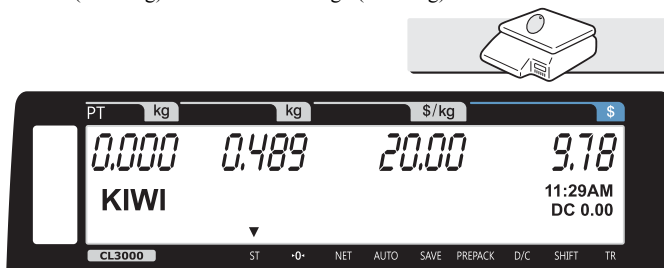

③ Place an item on the platter. In this case, discount is possible because the weight of item(0.526 kg) is greater than 1st target(0.500kg) therefore the total price is 10.26.

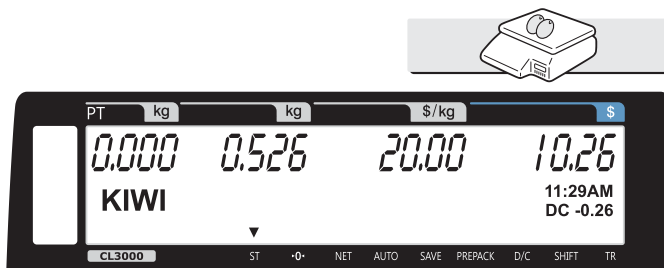

- ④ Place items on the platter. In this case, discount is possible because the weight of item (1.076 kg) is greater than 1st target(0.500 kg) therefore the total price is 20.44\$.

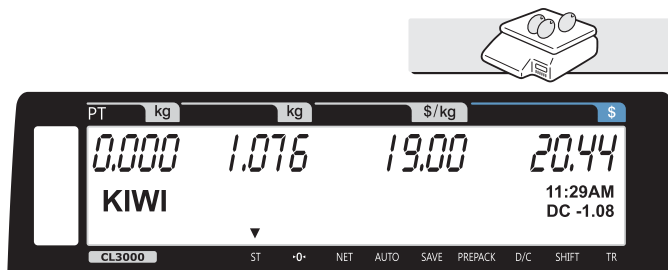

- ⑤ Press the PRINT key.
Markdown(~~STRIKE THROUGH~~) is printed on label as figure.



Note: - You can set four markdown information in menu 1720 of program mode.
(See chapter 2.9.3)

- If you set "display discount info." to "Y" in menu 1871 of program mode, you can see total price and discount information on the display.
(See chapter 2.10.21)

3.7.2 % Unit Price Discount - By Weight PLU

EXAMPLE:

- PLU# 29=ORANGE (By-Weight PLU), Unit price=20.00

- 1st Target of Discount : "10 % off from unit price" for sales weight \geq 0.500 kg.
- 2nd Target of Discount : "20 % off from unit price" for sales weight \geq 1.000 kg.

- ① Call up a PLU.

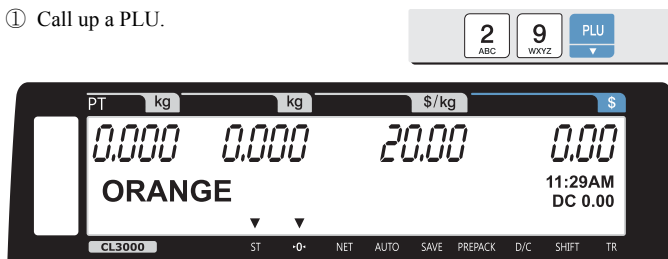

* User may call up a PLU by pressing speed key or numeric key.
Please refer to chapter 3.4 for details.

- ② Place an item on the platter. In this case, discount is not available because the weight of this item(0.489 kg) is lower than 1st target(0.500 kg).

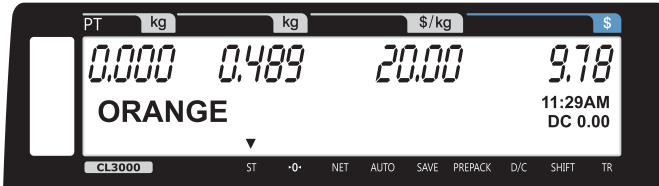

- ③ Place items on the platter. In this case, the weight of items(0.526 kg) is greater than 1st target(0.500 kg) therefore you can have 10% discount. (Total price is 9.47)

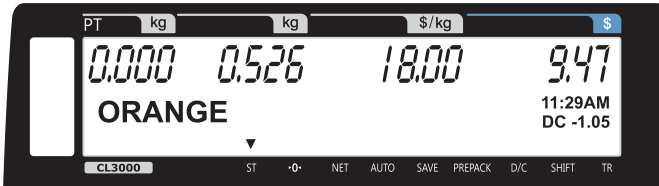

- ④ Place items on the platter. In this case, the weight of items(1.076kg) is greater than 2nd target(1.000kg) therefore you can have 20% discount. (Total price is 17.22)

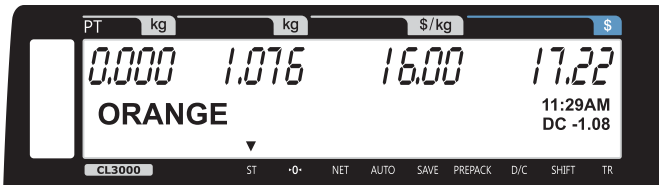

- ⑤ Press the PRINT key.
Markdown(~~STRIKE THROUGH~~) is printed on label as figure.



3.7.3 Unit Price Discount - By PCS PLU

EXAMPLE 2:

- PLU# 30=PREMIUM MANGO, 3 pieces FOR 6.00

- 1st Target of Discount: "Discount amount from unit price"=0.20 for sales \geq 5 pieces.
- 2nd Target of Discount: "Discount amount from unit price"=0.50 for sales \geq 10 pieces.

① Call up a PLU.

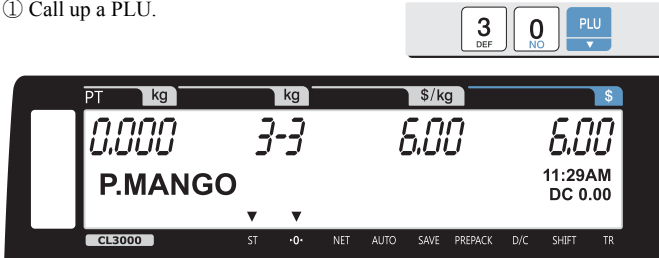

② Enter quantity. In this case, 5 is greater than 1st Target (5), unit price(0.20\$) is discounted.

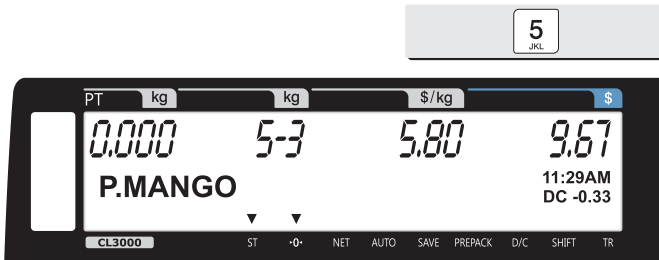

③ Enter quantity. In this case, 11 is greater than 2nd Target (10), unit price(0.50\$) is discounted.

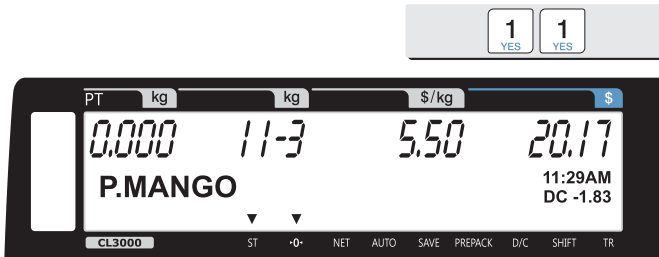

④ Press the PRINT key.

Markdown(~~STRIKE THROUGH~~)s printed on label as figure.



Note: You can set four markdown information in menu 1720 of program mode.
(See chapter 2.9.3)

3.8 Add-Up Transaction

If you press the ADD key instead of the PRINT key, you will initiate the ADD-UP process. You can ADD-UP 100 items maximum.

EXAMPLE 2:

- PLU# 32=SIRLOIN, PLU Type = By-Weight, Unit Price=20.00,
- PLU# 35=T-bone Steak, PLU Type = By-PCS, Pieces=3, Unit Price=6.00

① Call up a PLU and place item on the platter.

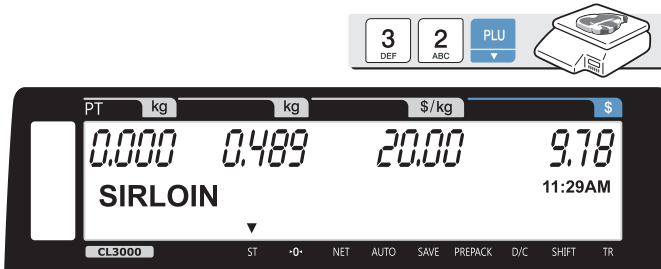

② Press ADD key. PLU is cleared automatically. You will see the display as below.

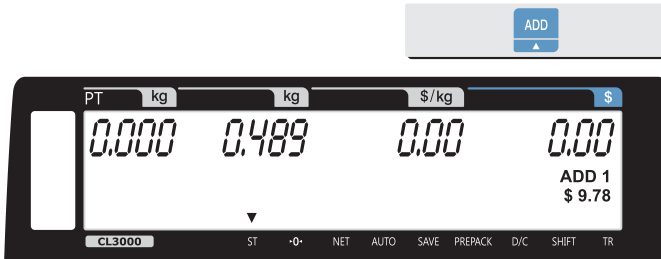

③ Remove item from the platter and call up a PLU.

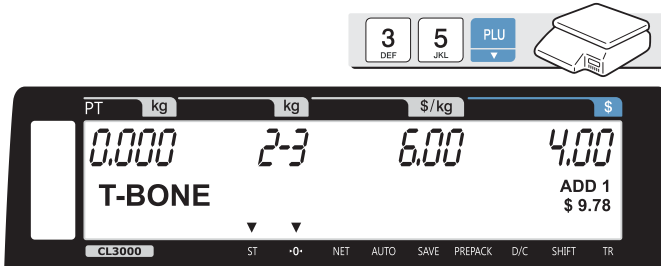

- ④ Press ADD key. PLU is cleared automatically. You will see the display as below.

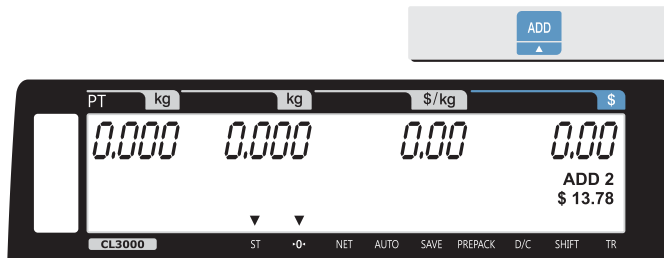

- ⑤ You can repeat the ADD-UP process up to 100 times or you can press the ST/TTL key at anytime to see the grand-total.

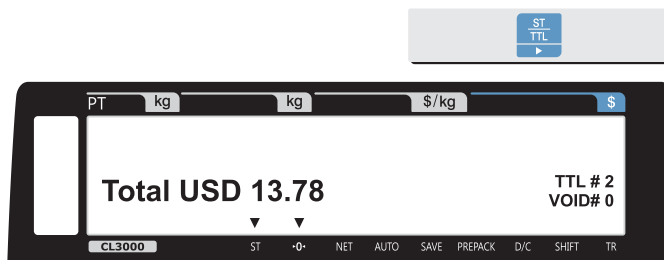

- ⑥ To complete the sale, press the PRINT key. (To repeat the ADD-UP process, press the ESC key.)



- Note:**
- You can press the VOID key to undo the transaction. (See chapter 3.10).
 - If you set "Print Item Label" to "Y" in menu 1750 of program mode, label will be printed whenever you press the ADD key. (See chapter 2.9.3)
 - Even though you turn off the scale before printing a grand total label, add-up data is not cleared.

3.9 Clerk Operation

There are three clerk modes as below.

► Clerk Modes

| No. | Clerk Modes | Description |
|-----|----------------|--|
| 1 | No Clerk | Sales clerk does not log in and makes sales using "PRINT" key. |
| 2 | Standard Clerk | Generating a standard clerk transaction is the same as any sales mode transaction except that you do NOT press the PRINT key; instead you must press one of the V(Clerk-Speed) keys (1 through 4) You can print total price label depending on the setting. |
| 3 | Floating Clerk | Generating a standard clerk transaction is the same as any sales mode transaction except that you do NOT press the PRINT key; instead you must press one of the V(Clerk-Speed) keys (1 through 4) You can print total price label depending on the setting. Sales data is added automatically. |

☞ To register clerk, refer to menu code 1850 of program mode. (See chapter 2.10.6)

Assumption

- Clerk should be registered on menu 1850. (See chapter 2.10.6)
- Clerk number should be set on menu 1856 to use "V1, V2, V3, and V4" keys (See chapter 2.10.12) If the clerk is not assigned to V1~V4, this clerk has to enter password after pressing V key.
- All clerks can use "V" key.
- * Up to 100 transactions are available in Clerk mode
- * Sales data is saved in memory.
- * If you press PRINT key to complete transaction, grand total price is printed and sales data is cleared from memory.
- * If you want to see total price before completing transaction, press the ST/TTL key. To print, press the PRINT key.
- * Even though you turn off the scale before printing, sales data is not cleared.
- * If you want to print ticket when you log out, press V1, V2, V3 or V4 to log on and press the PRINT key. You can also check total price by pressing ST/TTL key after log on.

Note: - You have to set Clerk log out time in menu 1874 of program mode. (See chapter 2.10.21) If you do not call a PLU and do not operate the scale, time is computed. To set 30 seconds for logout time, enter 300. If you do not want to log out, enter 0.

- When there is no PLU, you can print ticket again by pressing X key (It depends on the setting of parameter 599, Print last ticket)

3.9.1 Standard Clerk Operation

Assumption

- You have to set "Select Clerk Sale mode" to "2" (Standard Clerk) in menu 1820 of program mode. (See chapter 2.10.3)

EXAMPLE 2:

Clerk No: 2, Clerk Name: Christine, Clerk Key: V1
 PLU#1=Apple, Unit Price 10.00, Weight, 1.2 kg
 PLU#2=Orange, Unit Price 20.00, Weight, 1.2 kg

- ① Call up a PLU.

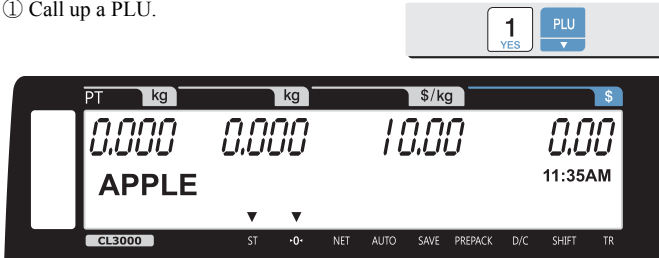

- ② Place an item and press V1 key. You will get a label automatically.

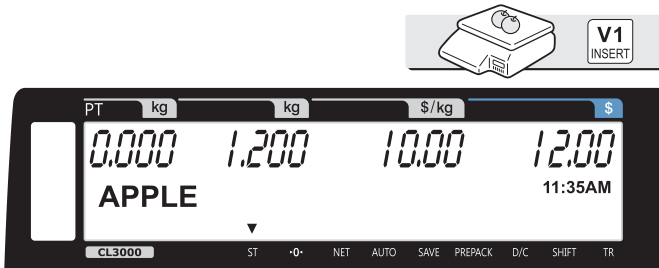

- ③ Call up a PLU.

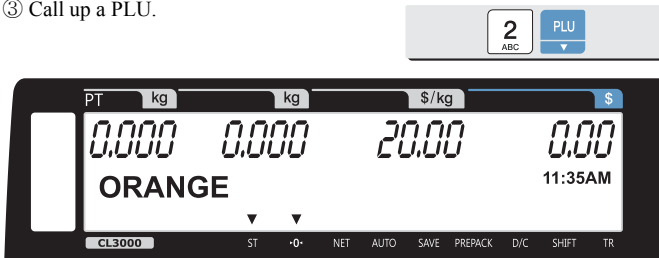

- ④ Place an item and press V1 key. You will get a label automatically.

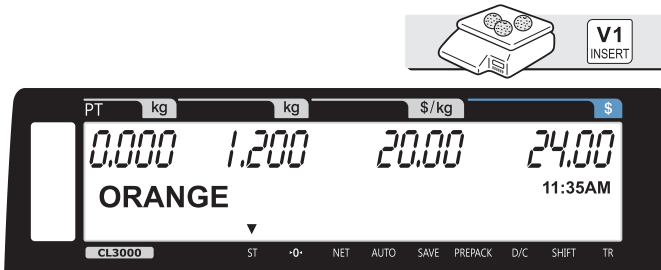

- ⑤ Press the PRINT key to complete transaction. If you are in ADD-UP mode, you can have label for grand total price.

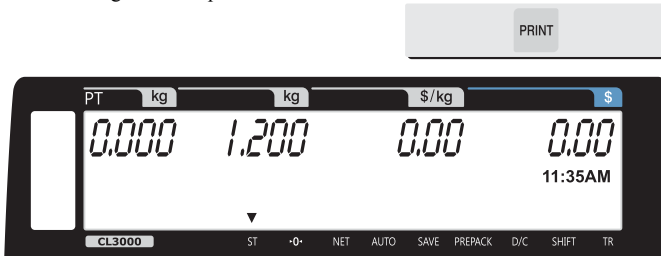

Note: - If you are in ADD-UP mode, you can have label for grand total price by pressing PRINT key. When you turn on the scale, this function is not active so you have to press ADD key.

3.9.2 Floating Clerk Operations

Assumption

- You have to set "Select Clerk Sale mode" to "3" (Floating Clerk) in menu 1820 of program mode. (See chapter 2.10.3)

EXAMPLE :

Clerk No: 2, Clerk Name: Christine, Clerk Key: V1
 PLU#1=Apple, Unit Price 10.00.
 PLU#2=Orange, Unit Price 20.00

① Call up a PLU.

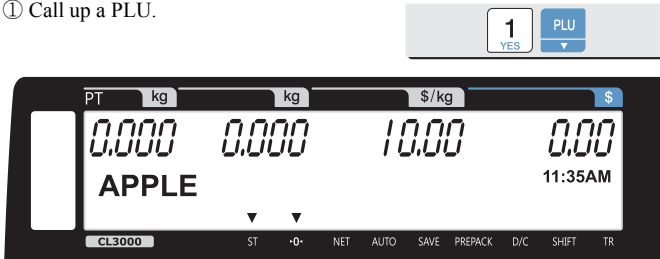

② Place an item on the platter and press the V1 key. This transaction is save to memory.

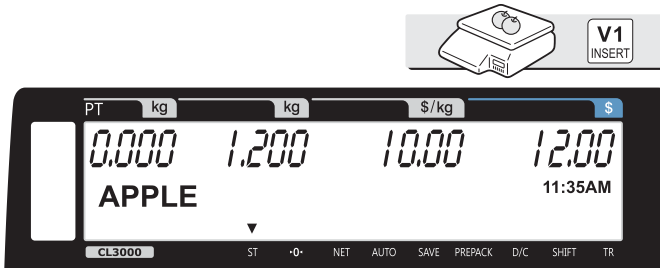

③ Call up a PLU #2.

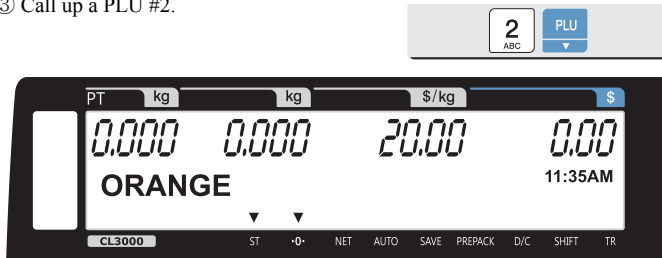

④ Place an item on the platter and press the V1 key. This transaction is saved to memory.

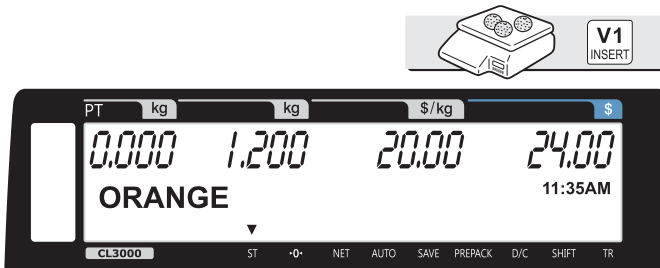

- ⑤ Press the PRINT key to complete transaction. Grand total price label is printed and sales data is cleared in memory.

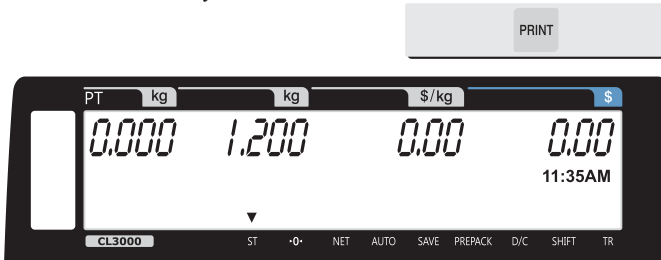

Note: - Print mode of floating clerk operation is ticket type as default. If you want to use label type, you have to change setting in menu 1731 of program mode. (See chapter 2.9.5)

- You can set ticket item in menu 1761 of program mode. (See chapter 2.9.15)

3.10 Void

You can press the VOID key to undo transaction in add-up process or floating clerk operation.

Assumption)

You sold several items

◆ If there is no PLU or price is zero.

① Press the VOID key, you will see following screen.

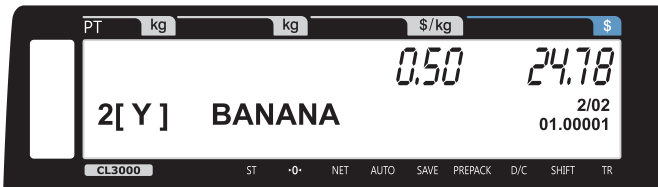
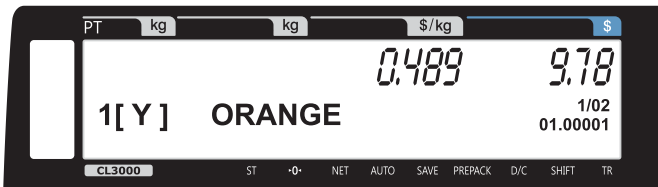

② To void ORNAGE, enter 0 by pressing numeric key and press the PRINT.

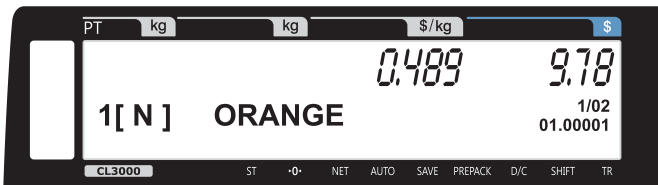

② To finish, press the ESC key

※ You can use the PG UP and PG DOWN keys or the Arrow keys to navigate up and down the list.

◆ If there is same PLU and same price to void

① Place item on the platter

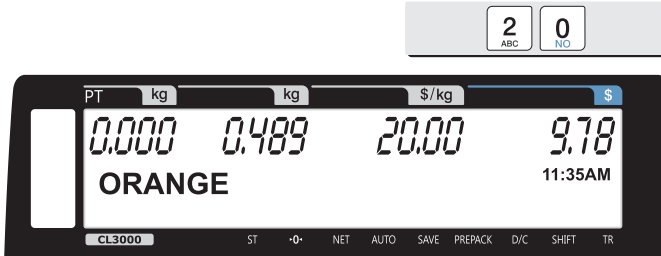

② Press VOID key then this sale is cleared.

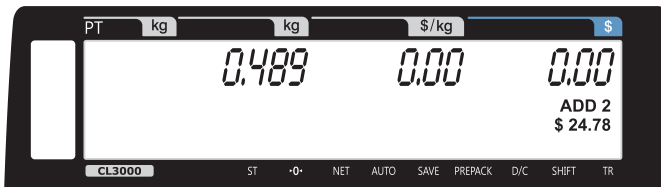

※ If price is not same, void list screen is shown on the display automatically.

3.11 Payment & Change

► Payment

| No. | Type |
|-----|-------------|
| 1 | Cash |
| 2 | Pin/chip |
| 3 | Check |
| 4 | Credit card |
| 5 | Credit note |
| 6 | Coupon |
| 7 | Bonus point |

You can use PAY key in the add-up process or floating clerk operation.

EX) Total price : 15.00 \$

If customer give 6.00 coupon and cash 10.00 \$ to clerk

- ① Press PAY key when there is subtotal price

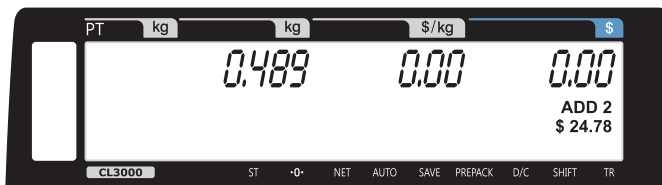

- ② Select payment type 5(coupon) and press PRINT key.

※ See Payment table.

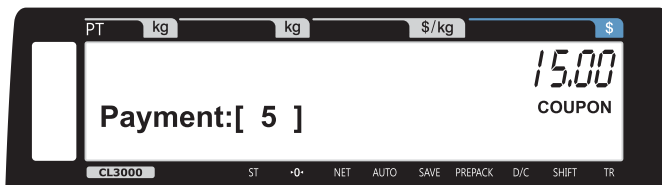

- ③ Enter 6.00



④ Press PRINT key then you can select payment type again.

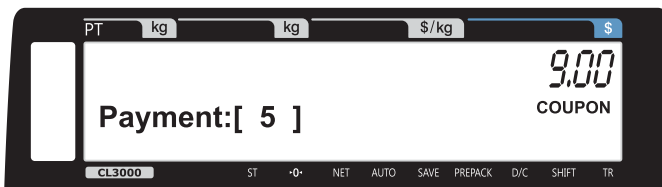

⑤ Select Payment type (0 cash) and press PRINT key.

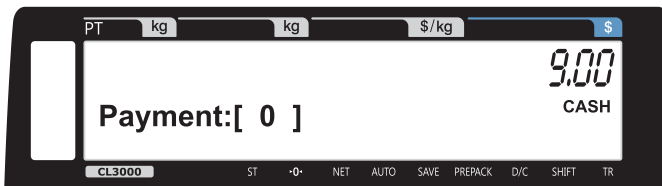

⑥ Enter 10.00.

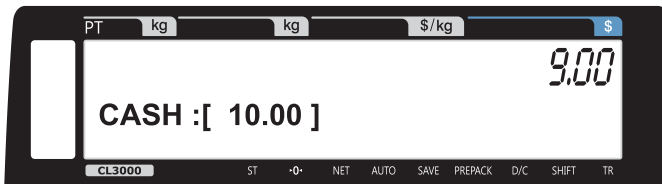

⑦ Press PRINT key. The label is issued.

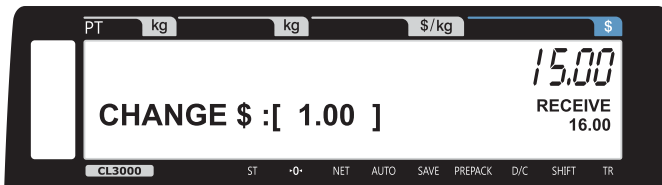

※ Total price, receive and change is printed.

Note: - You can set print item in menu 1760 of program mode. (See chapter 2.9.14)
- If there is credit, a receipt is printed additionally.

3.12 Return

The RETURN key is used to delete erroneous sale transactions. You can use the RETURN key to undo erroneous sales transactions like pressing the PRINT key inadvertently, selecting and printing the wrong PLU, an inadvertent Auto-Print in Pre-Pack mode, or perhaps adjusting the sales totals for a damaged or ruined package. Whatever the reason, the RETURN function will decrement returned PLU's transaction counter and sales totals by the specified amount.

You need to call-up the PLU that you wish to return by either pressing its corresponding speed key or typing its number.

◆ When the price is zero,

0) By weight PLU : You need to enter the total price and weight that was printed on the return PLU's label

1) By count PLU: You need to enter the total price and quantity that was printed on the return PLU's label

◆ When the price is higher than zero,

Return function is performed by pressing RETURN key

Note: - If you set "Shift key instead return key" to "Y" in menu 1873 of program mode, you cannot use return function. (See chapter 2.10.21)

- If parameter 596 X/Z Report is not set, this function is not operated.

3.13 Prepack Key

When the scale is in Pre-Pack mode, it prints labels automatically. When it is in MANUAL mode, you must press the PRINT key (or ADD key) to get a label. In Pre-Pack mode, you cannot select AUTO mode. Pre-Pack works like AUTO and SAVE mode except that the weight does not need to return to zero for every auto-print.

Pre-pack mode is very useful in back-room applications. This mode increases productivity by not requiring the user to press the PRINT key for every package. Instead the user can concentrate on weighing, wrapping, and labeling.

This function is only available for by-weight PLU.

EXAMPLE:

Speed key #1="Onion" Unit price=1.50, Sales Weight=1.0kg,

- ① Press PREPACK key and call up a PLU

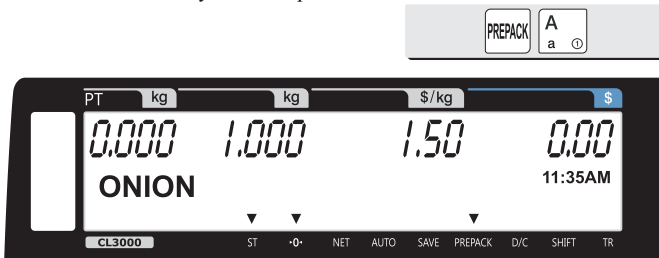

- ◆ User may call up a PLU by pressing speed key or numeric key. Please refer to Menu code 1160.

- ② Place the item(s) on the platter.

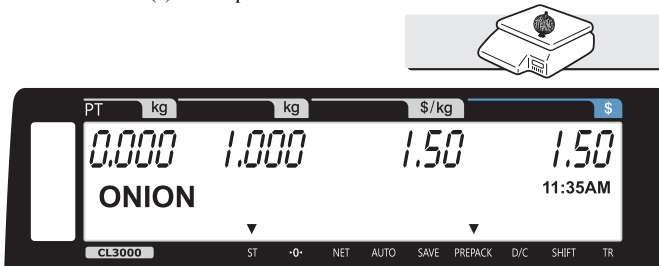

③ Label is issued automatically.

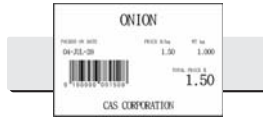

④ Remove the item(s) from the platter.

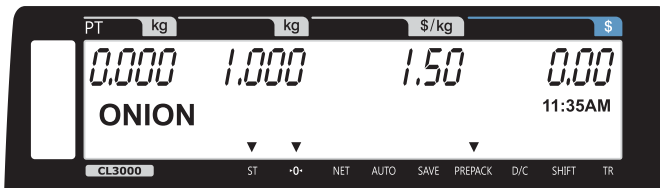

Note: - If the scale is in Prepack mode then it will always auto-print if the Total price is greater than 0.00 and:

1. The weight deviates by an amount greater than or equal to the Parameter 862 setting (Min. weight for sale) and the weight stabilizes at a weight greater than zero.
2. The weight deviates by an amount greater than or equal to the Parameter 861 setting (Auto threshold) and the weight stabilizes at a weight greater than zero.

3.14 X Key

The X key is used to print multiple transactions for the same PLU.
The X key operation is called the Multi-Label function.

3.14.1 By-Weight PLU

Note: If you want to use X key for by-weight PLU, you must set Parameter 582, Use 'X' key (by WT.).

EXAMPLE:

Speed key #1= "Onion" preset key, Unit price=1.50, Sales Weight=1.0kg,

- ① Call up a PLU

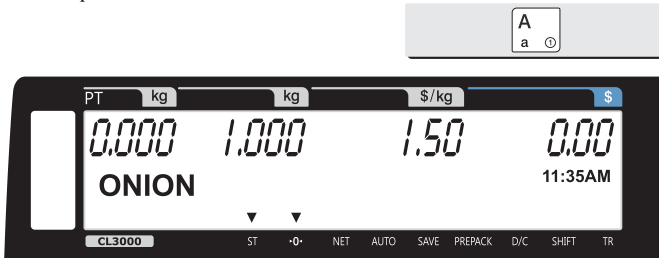

- ◆ User may call up a PLU by pressing speed key key or numeric key.
Please refer to chapter 3.4 for details.

- ② Place the item(s) on the platter.

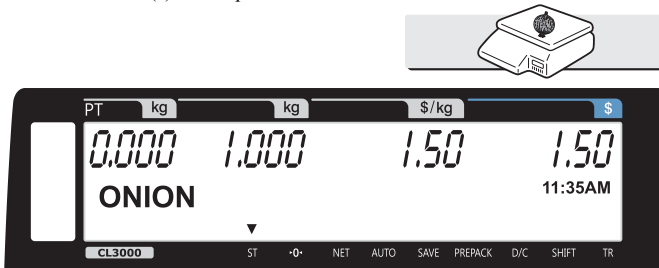

③ Type the number of labels you require and press the PRINT key.

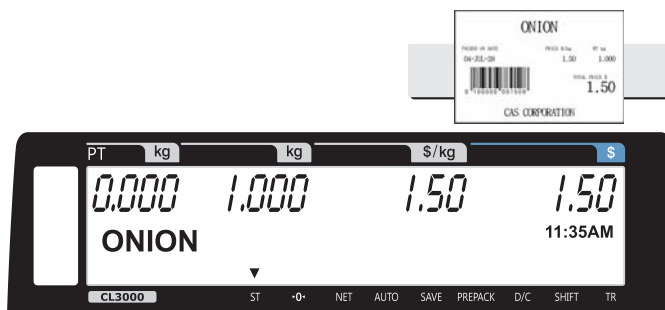

④ Remove the item(s) from the platter.

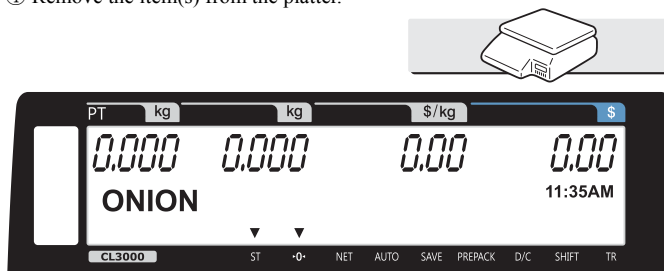

Note: - If you set "Label Prt. w.o Rewind (X Key)" to "Y" in menu 1872 of program mode, the scale does not check peel-off, so you have to press FEED key after printing is done. (See chapter 2.10.21)

- If you set "Use double print(AUTO)" to "Y" in menu 1872 of program mode, you will have two same labels in auto mode.

- If you set 2nd label in PLU programming, 2nd label is issued automatically.

3.14.2 Non-Weighed PLU

You can use X key for by Count, By PCS PLU without any setting.
The way of using X key is same as by-weight PLU except weighing item.

3.15 How to Change Sell By Date/Time

- ① Call up a PLU

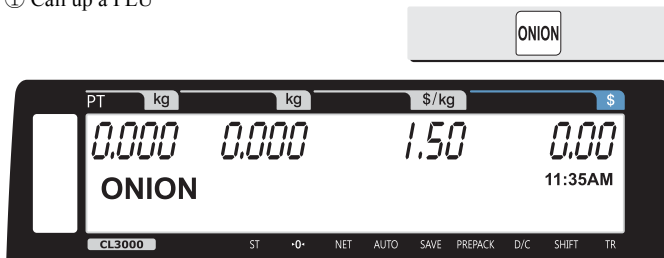

- ② Press EDIT SELL key to enter both of effective date and time.

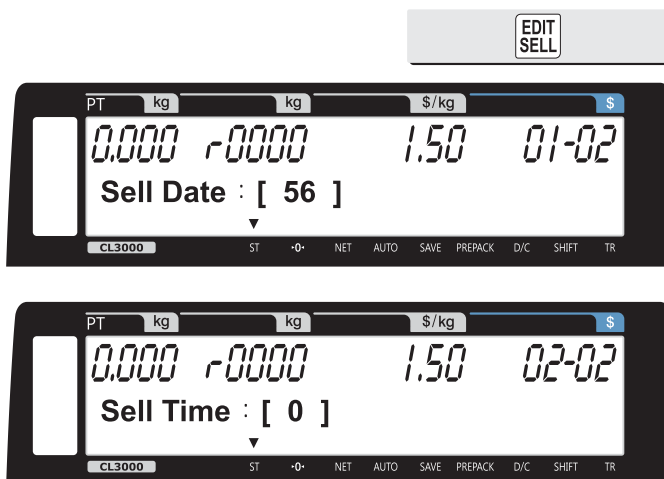

- ③ Press PRINT key to complete saving.

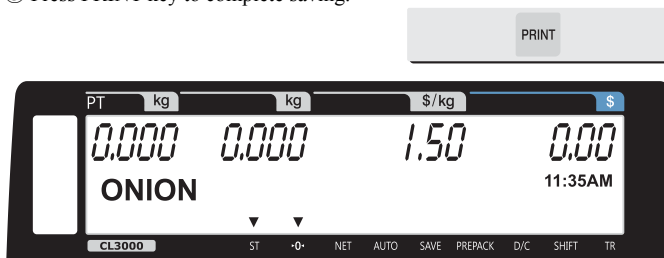

Note: - To use EDIT SELL key, you have to set this key in menu 1880 of program mode.
(See chapter 2.10.22)

3.16 How to Change Origin

- ① Call up a PLU

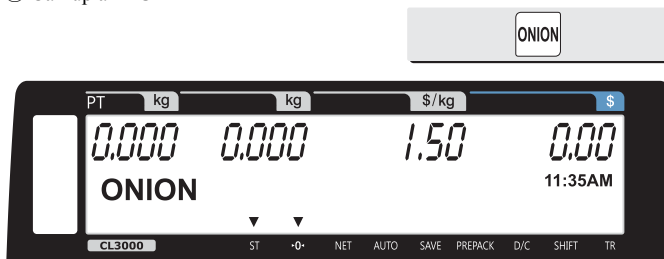

- ② Press ORIGIN key to retrieve one of origin data saved.

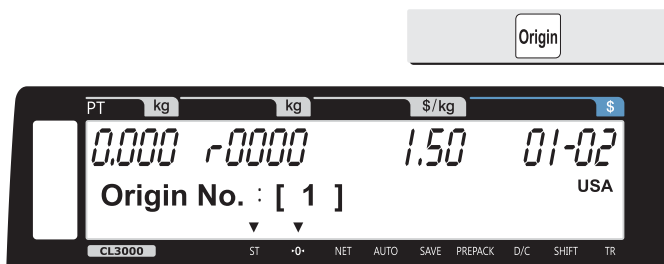

Note: - To use ORIGIN key, you have to set this key in menu 1880 of program mode.
(See chapter 2.10.22)

3.17 How to Change PLU Type

Note: If you set "Save Type change" to "Y" in menu 1873 of program mode, changed PLU type is saved. (See chapter 2.10.21)

- ① Press "WT/CT" key to change PLU type from By-weight to By-count PLU or vice versa.

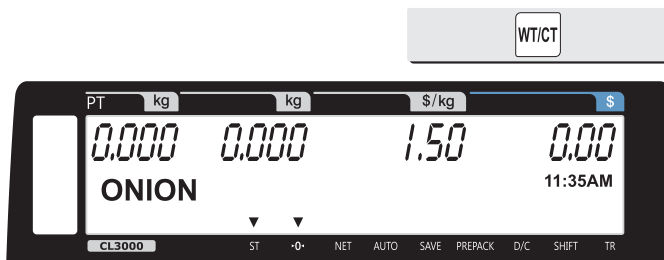

- ☞ If you change by-Weight PLU to by-count PLU, quantity is set 1 and unit price is same.
- ☞ If you change by-count PLU to by-weight PLU, unit price is same.
- ☞ If there is discount information in PLU, you can not change PLU type.

3.18 Direct Discount

If there is no discount information in PLU, you can use this function.

3.18.1 Fixed Price Key

① Call up a PLU # 1 and press “Fixed Price” key.

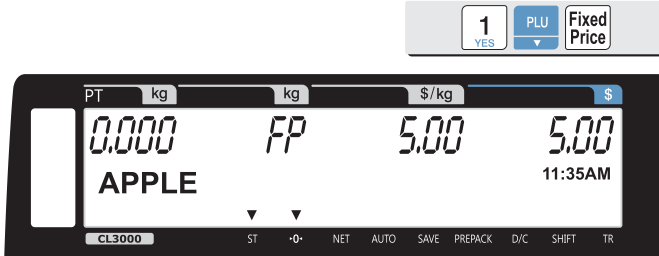

② Press “Override Key”

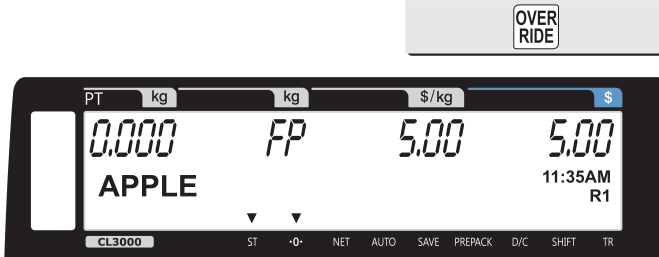

③ Type fixed price 2.00 than press PRINT key

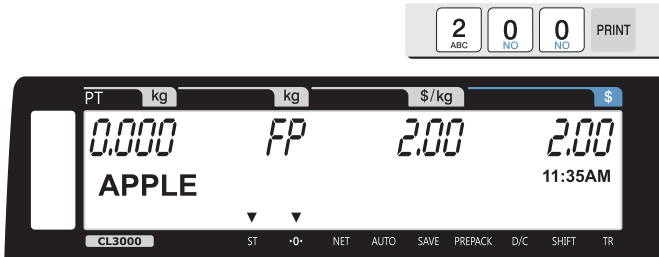

Note: - To use Fixed Price Key, you have to set this key in menu 1880 of program mode. (See chapter 2.10.22)

3.18.2 % Discount Price Key

- ① Call up a PLU(#1.APPLE) and press “%Discount” key

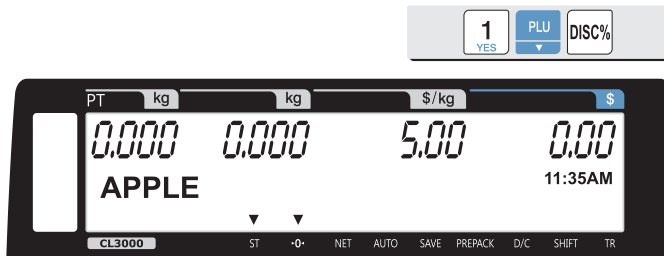

- ② Enter % amount to discount and press PRINT key

Ex) 20%

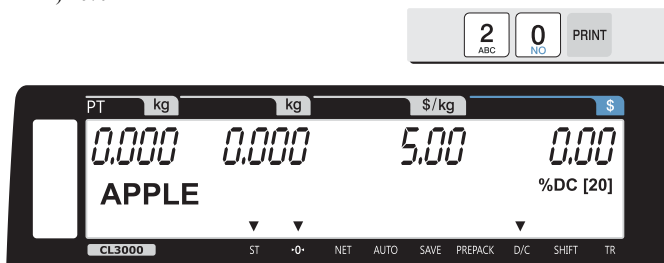

- ③ Place item on the platter and press PRINT key.

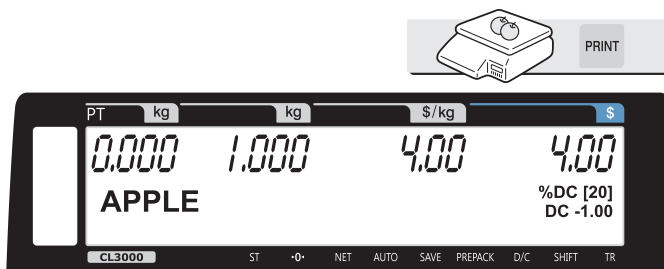

Note: - To use % DISCOUNT key, you have to set this key in menu 1880 of program mode. (See chapter 2.10.2)

3.19 PLU Connection

3.19.1 Referenced PLU Function

If you press REFERENCE key after calling up a PLU which has reference information, reference will be shown on the display.

- ☞ To use this function, you have to set reference department and reference PLU when you create PLU.

3.19.2 Coupled PLU Function

Automatically coupled PLU is called up after transaction.
You can use this function when you sell two or more items as package.

- ☞ To use this function, you have to set coupled department and coupled PLU when you create PLU.

3.19.3 Linked PLU Function

You can use this function when you sell two or more items at a time.

- ☞ To use this function, you have to set linked department and linked PLU when you create PLU.

3.20 Sales Operation Control Parameters

3.20.1 Fixed Weight

- You can set fixed weight when you create PLU
If you call up this PLU, the weight is not changed.
- You can use IN WEIGHT key.
Call up a PLU and enter a fixed weight by using OVERRIDE key and press IN WEIGHT key.

3.20.2 Prepack Without Report

The transaction data is not added to report while using prepack mode.

- You have to set Parameter 597(Prepack report) to use this function.
Also, Parameter 596 should be set to Y

4. APPENDIX

4.1 Label Format

There are fixed label format and user label format

| | Fixed Label Format | User Label Format |
|----------|-------------------------|--|
| No. | 1~50 | 51~99 |
| Quantity | 45 | 20 |
| Method | Built in CL3000 | Download from PC |
| Features | You cannot edit format. | Using the PC program, you can program format numbers 51 to 99. In ticket mode, it is available to use Head/Tail format. |

► Fixed Label Format

| No | Name | Width (mm) | Height (mm) | No | Name | Width (mm) | Height (mm) |
|----|--------------|------------|-------------|----|--------------|------------|-------------|
| 1 | IS6030-00001 | 60 | 30 | 24 | IS5068-00024 | 50 | 68 |
| 2 | IS6030-00002 | 60 | 30 | 25 | IS5068-00025 | 50 | 68 |
| 3 | IS6030-00003 | 60 | 30 | 26 | IS5068-00026 | 50 | 68 |
| 4 | IS5635-00004 | 56 | 35 | 27 | IS6063-00027 | 60 | 63 |
| 5 | IS5635-00005 | 56 | 35 | 28 | IS6063-00028 | 60 | 63 |
| 6 | IS5635-00006 | 56 | 35 | 29 | IC6040-00029 | 60 | 40 |
| 7 | IS6040-00007 | 60 | 40 | 30 | IC6040-00030 | 60 | 40 |
| 8 | IS6040-00008 | 60 | 40 | 31 | IS6040-KR001 | 60 | 40 |
| 9 | IS6040-00009 | 60 | 40 | 32 | IS6030-KR002 | 60 | 30 |
| 10 | IS6040-00010 | 60 | 40 | 33 | IS6032-KR003 | 60 | 32 |
| 11 | IS6040-00011 | 60 | 40 | 34 | IS6060-KR004 | 60 | 60 |
| 12 | IS6040-00012 | 60 | 40 | 35 | IS6032-KR005 | 60 | 32 |
| 13 | IS5040-00013 | 50 | 40 | 36 | IS6042-KR006 | 60 | 42 |
| 14 | IS5040-00014 | 50 | 40 | 37 | IS6045-KR007 | 60 | 45 |
| 15 | IS5040-00015 | 50 | 40 | 38 | IS6050-KR008 | 60 | 50 |
| 16 | IS5653-00016 | 56 | 53 | 39 | IS6045-KR009 | 60 | 45 |
| 17 | IS5653-00017 | 56 | 53 | 40 | IS6040-KR010 | 60 | 40 |
| 18 | IS5054-00018 | 50 | 54 | 41 | IS6040-KR011 | 60 | 40 |
| 19 | IS5054-00019 | 50 | 54 | 42 | IS6045-KR012 | 60 | 45 |
| 20 | IS6051-00020 | 60 | 51 | 43 | IS6044-KR013 | 60 | 44 |
| 21 | IS6051-00021 | 60 | 51 | 44 | IS6055-KR014 | 60 | 55 |
| 22 | IS6060-00022 | 60 | 60 | 45 | IS6060-KR015 | 60 | 60 |
| 23 | IS6060-00023 | 60 | 60 | | | | |

| 1 | 2 | 3 | | | | | | | | | | | | | | | | | | | | | | | | | | | | | | | | | | | | | | | | | | |
|--|------------|-------------|------------|------------|-----------|-------------|---|----------|------------|-----------|---|-------------|---|---|---|----------|------------|-----------|-------------|-------------|----------|---|-----------|------------|-------------|--|----------|------------|-------------|---|------------|-------------|-----------|----------|----------|-----------|------------|-------------|-------|-------|-------|--------|------------|-------------|
| <p>SWEETENED CONDENSED MILK <VERY SWEET and STICKY></p> <p>Tare(kg) : 0.100</p> <table border="1"> <tr> <td>20.11.05</td> <td>26.11.05</td> <td>1.216</td> <td>32.00</td> <td>38.91</td> </tr> <tr> <td>PACKED ON</td> <td>SELL BY</td> <td>NET WT</td> <td>UNIT PRICE</td> <td>PRICE</td> </tr> </table> <p>CAS CORPORATION +82-31-820-1100 #19 Gangp-ri Gangbuk-gu</p> | 20.11.05 | 26.11.05 | 1.216 | 32.00 | 38.91 | PACKED ON | SELL BY | NET WT | UNIT PRICE | PRICE | <p>SWEETENED CONDENSED MILK Whole milk that had 60% of the water removed and sugar added. The amount of sugar added makes up 40% of the</p> <p>Tare(kg) : 0.100</p> <table border="1"> <tr> <td>20.11.05</td> <td>26.11.05</td> <td>1.216</td> <td>32.00</td> <td>38.91</td> </tr> <tr> <td>PACKED ON</td> <td>SELL BY</td> <td>NET WT</td> <td>UNIT PRICE</td> <td>PRICE</td> </tr> </table> <p>CAS CORPORATION +82-31-820-1100 #19 Gangp-ri Gangbuk-gu</p> | 20.11.05 | 26.11.05 | 1.216 | 32.00 | 38.91 | PACKED ON | SELL BY | NET WT | UNIT PRICE | PRICE | <p>SWEETENED CONDENSED MILK</p> <p>Tare(kg) : 0.100</p> <table border="1"> <tr> <td>20.11.05</td> <td>26.11.05</td> <td>1.216</td> <td>32.00</td> <td>38.91</td> </tr> <tr> <td>PACKED ON</td> <td>SELL BY</td> <td>NET WT</td> <td>UNIT PRICE</td> <td>PRICE</td> </tr> </table> <p>CAS CORPORATION +82-31-820-1100 #19 Gangp-ri Gangbuk-gu</p> | 20.11.05 | 26.11.05 | 1.216 | 32.00 | 38.91 | PACKED ON | SELL BY | NET WT | UNIT PRICE | PRICE | | | | | | | | | | | | |
| 20.11.05 | 26.11.05 | 1.216 | 32.00 | 38.91 | | | | | | | | | | | | | | | | | | | | | | | | | | | | | | | | | | | | | | | | |
| PACKED ON | SELL BY | NET WT | UNIT PRICE | PRICE | | | | | | | | | | | | | | | | | | | | | | | | | | | | | | | | | | | | | | | | |
| 20.11.05 | 26.11.05 | 1.216 | 32.00 | 38.91 | | | | | | | | | | | | | | | | | | | | | | | | | | | | | | | | | | | | | | | | |
| PACKED ON | SELL BY | NET WT | UNIT PRICE | PRICE | | | | | | | | | | | | | | | | | | | | | | | | | | | | | | | | | | | | | | | | |
| 20.11.05 | 26.11.05 | 1.216 | 32.00 | 38.91 | | | | | | | | | | | | | | | | | | | | | | | | | | | | | | | | | | | | | | | | |
| PACKED ON | SELL BY | NET WT | UNIT PRICE | PRICE | | | | | | | | | | | | | | | | | | | | | | | | | | | | | | | | | | | | | | | | |
| 4 | 5 | 6 | | | | | | | | | | | | | | | | | | | | | | | | | | | | | | | | | | | | | | | | | | |
| <p>SWEETENED CONDENSED MILK <VERY SWEET and STICKY></p> <p>Whole milk that had 60% of the water removed and sugar added. The amount of sugar added makes up 40% of the</p> <table border="1"> <tr> <td>26.11.05</td> <td>32.00</td> <td>38.91</td> </tr> <tr> <td>PACKED ON</td> <td>NET WT</td> <td>TOTAL PRICE</td> </tr> </table> <p>Thank You CAS CORPORATION +82-31-820-1100 #19 Gangp-ri Gangbuk-gu</p> | 26.11.05 | 32.00 | 38.91 | PACKED ON | NET WT | TOTAL PRICE | <p>SWEETENED CONDENSED MILK Whole milk that had 60% of the water removed and sugar added. The amount of sugar added makes up 40% of the</p> <table border="1"> <tr> <td>26.11.05</td> <td>32.00</td> <td>38.91</td> </tr> <tr> <td>PACKED ON</td> <td>NET WT</td> <td>TOTAL PRICE</td> </tr> </table> <p>Thank You CAS CORPORATION +82-31-820-1100 #19 Gangp-ri Gangbuk-gu</p> | 26.11.05 | 32.00 | 38.91 | PACKED ON | NET WT | TOTAL PRICE | <p>SWEETENED CONDENSED MILK Whole milk that had 60% of the water removed and sugar added. The amount of sugar added makes up 40% of the</p> <table border="1"> <tr> <td>26.11.05</td> <td>32.00</td> <td>38.91</td> </tr> <tr> <td>PACKED ON</td> <td>NET WT</td> <td>TOTAL PRICE</td> </tr> </table> <p>Thank You CAS CORPORATION +82-31-820-1100 #19 Gangp-ri Gangbuk-gu</p> | 26.11.05 | 32.00 | 38.91 | PACKED ON | NET WT | TOTAL PRICE | | | | | | | | | | | | | | | | | | | | | | | | |
| 26.11.05 | 32.00 | 38.91 | | | | | | | | | | | | | | | | | | | | | | | | | | | | | | | | | | | | | | | | | | |
| PACKED ON | NET WT | TOTAL PRICE | | | | | | | | | | | | | | | | | | | | | | | | | | | | | | | | | | | | | | | | | | |
| 26.11.05 | 32.00 | 38.91 | | | | | | | | | | | | | | | | | | | | | | | | | | | | | | | | | | | | | | | | | | |
| PACKED ON | NET WT | TOTAL PRICE | | | | | | | | | | | | | | | | | | | | | | | | | | | | | | | | | | | | | | | | | | |
| 26.11.05 | 32.00 | 38.91 | | | | | | | | | | | | | | | | | | | | | | | | | | | | | | | | | | | | | | | | | | |
| PACKED ON | NET WT | TOTAL PRICE | | | | | | | | | | | | | | | | | | | | | | | | | | | | | | | | | | | | | | | | | | |
| 7 | 8 | 9 | | | | | | | | | | | | | | | | | | | | | | | | | | | | | | | | | | | | | | | | | | |
| <p>SWEETENED CONDENSED MILK <VERY SWEET and STICKY></p> <p>UNIT PRICE/kg WEIGHT/kg</p> <table border="1"> <tr> <td>32.00</td> <td>1.216</td> <td>38.91</td> </tr> <tr> <td>UNIT PRICE</td> <td>WEIGHT</td> <td>TOTAL PRICE</td> </tr> </table> <p>Tare(kg) : 0.100</p> <table border="1"> <tr> <td>20.11.05</td> <td>26.11.05</td> <td>38.91</td> </tr> <tr> <td>PACKED ON</td> <td>SELL BY</td> <td>TOTAL PRICE</td> </tr> </table> <p>CAS CORPORATION +82-31-820-1100 #19 Gangp-ri Gangbuk-gu</p> | 32.00 | 1.216 | 38.91 | UNIT PRICE | WEIGHT | TOTAL PRICE | 20.11.05 | 26.11.05 | 38.91 | PACKED ON | SELL BY | TOTAL PRICE | <p>SWEETENED CONDENSED MILK Whole milk that had 60% of the water removed and sugar added. The amount of sugar added makes up 40% of the</p> <table border="1"> <tr> <td>32.00</td> <td>1.216</td> <td>38.91</td> </tr> <tr> <td>UNIT PRICE</td> <td>WEIGHT</td> <td>TOTAL PRICE</td> </tr> </table> <p>Tare(kg) : 0.100</p> <table border="1"> <tr> <td>20.11.05</td> <td>26.11.05</td> <td>38.91</td> </tr> <tr> <td>PACKED ON</td> <td>SELL BY</td> <td>TOTAL PRICE</td> </tr> </table> <p>CAS CORPORATION +82-31-820-1100 #19 Gangp-ri Gangbuk-gu</p> | 32.00 | 1.216 | 38.91 | UNIT PRICE | WEIGHT | TOTAL PRICE | 20.11.05 | 26.11.05 | 38.91 | PACKED ON | SELL BY | TOTAL PRICE | <p>SWEETENED CONDENSED MILK</p> <p>UNIT PRICE/kg WEIGHT/kg</p> <table border="1"> <tr> <td>32.00</td> <td>1.216</td> <td>38.91</td> </tr> <tr> <td>UNIT PRICE</td> <td>WEIGHT</td> <td>TOTAL PRICE</td> </tr> </table> <p>Tare(kg) : 0.100</p> <table border="1"> <tr> <td>20.11.05</td> <td>26.11.05</td> <td>38.91</td> </tr> <tr> <td>PACKED ON</td> <td>SELL BY</td> <td>TOTAL PRICE</td> </tr> </table> <p>CAS CORPORATION +82-31-820-1100 #19 Gangp-ri Gangbuk-gu</p> | 32.00 | 1.216 | 38.91 | UNIT PRICE | WEIGHT | TOTAL PRICE | 20.11.05 | 26.11.05 | 38.91 | PACKED ON | SELL BY | TOTAL PRICE | | | | | | |
| 32.00 | 1.216 | 38.91 | | | | | | | | | | | | | | | | | | | | | | | | | | | | | | | | | | | | | | | | | | |
| UNIT PRICE | WEIGHT | TOTAL PRICE | | | | | | | | | | | | | | | | | | | | | | | | | | | | | | | | | | | | | | | | | | |
| 20.11.05 | 26.11.05 | 38.91 | | | | | | | | | | | | | | | | | | | | | | | | | | | | | | | | | | | | | | | | | | |
| PACKED ON | SELL BY | TOTAL PRICE | | | | | | | | | | | | | | | | | | | | | | | | | | | | | | | | | | | | | | | | | | |
| 32.00 | 1.216 | 38.91 | | | | | | | | | | | | | | | | | | | | | | | | | | | | | | | | | | | | | | | | | | |
| UNIT PRICE | WEIGHT | TOTAL PRICE | | | | | | | | | | | | | | | | | | | | | | | | | | | | | | | | | | | | | | | | | | |
| 20.11.05 | 26.11.05 | 38.91 | | | | | | | | | | | | | | | | | | | | | | | | | | | | | | | | | | | | | | | | | | |
| PACKED ON | SELL BY | TOTAL PRICE | | | | | | | | | | | | | | | | | | | | | | | | | | | | | | | | | | | | | | | | | | |
| 32.00 | 1.216 | 38.91 | | | | | | | | | | | | | | | | | | | | | | | | | | | | | | | | | | | | | | | | | | |
| UNIT PRICE | WEIGHT | TOTAL PRICE | | | | | | | | | | | | | | | | | | | | | | | | | | | | | | | | | | | | | | | | | | |
| 20.11.05 | 26.11.05 | 38.91 | | | | | | | | | | | | | | | | | | | | | | | | | | | | | | | | | | | | | | | | | | |
| PACKED ON | SELL BY | TOTAL PRICE | | | | | | | | | | | | | | | | | | | | | | | | | | | | | | | | | | | | | | | | | | |
| 10 | 11 | 12 | | | | | | | | | | | | | | | | | | | | | | | | | | | | | | | | | | | | | | | | | | |
| <p>SWEETENED CONDENSED MILK <VERY SWEET and STICKY></p> <p>PACKED ON / SELL BY / WEIGHT</p> <table border="1"> <tr> <td>20.11.05</td> <td>26.11.05</td> <td>1.216</td> <td>38.91</td> </tr> <tr> <td>PACKED ON</td> <td>SELL BY</td> <td>WEIGHT</td> <td>PRICE</td> </tr> </table> <p>Tare(kg) : 0.100</p> <table border="1"> <tr> <td>32.00</td> <td>38.91</td> </tr> <tr> <td>UNIT PRICE</td> <td>PRICE</td> </tr> </table> <p>CAS CORPORATION +82-31-820-1100 #19 Gangp-ri Gangbuk-gu</p> | 20.11.05 | 26.11.05 | 1.216 | 38.91 | PACKED ON | SELL BY | WEIGHT | PRICE | 32.00 | 38.91 | UNIT PRICE | PRICE | <p>SWEETENED CONDENSED MILK Whole milk that had 60% of the water removed and sugar added. The amount of sugar added makes up 40% of the</p> <p>PACKED ON / SELL BY / WEIGHT</p> <table border="1"> <tr> <td>20.11.05</td> <td>26.11.05</td> <td>1.216</td> <td>38.91</td> </tr> <tr> <td>PACKED ON</td> <td>SELL BY</td> <td>WEIGHT</td> <td>PRICE</td> </tr> </table> <p>Tare(kg) : 0.100</p> <table border="1"> <tr> <td>32.00</td> <td>38.91</td> </tr> <tr> <td>UNIT PRICE</td> <td>PRICE</td> </tr> </table> <p>CAS CORPORATION +82-31-820-1100 #19 Gangp-ri Gangbuk-gu</p> | 20.11.05 | 26.11.05 | 1.216 | 38.91 | PACKED ON | SELL BY | WEIGHT | PRICE | 32.00 | 38.91 | UNIT PRICE | PRICE | <p>SWEETENED CONDENSED MILK</p> <p>PACKED ON / SELL BY / WEIGHT</p> <table border="1"> <tr> <td>20.11.05</td> <td>26.11.05</td> <td>1.216</td> <td>38.91</td> </tr> <tr> <td>PACKED ON</td> <td>SELL BY</td> <td>WEIGHT</td> <td>PRICE</td> </tr> </table> <p>Tare(kg) : 0.100</p> <table border="1"> <tr> <td>32.00</td> <td>38.91</td> </tr> <tr> <td>UNIT PRICE</td> <td>PRICE</td> </tr> </table> <p>CAS CORPORATION +82-31-820-1100 #19 Gangp-ri Gangbuk-gu</p> | 20.11.05 | 26.11.05 | 1.216 | 38.91 | PACKED ON | SELL BY | WEIGHT | PRICE | 32.00 | 38.91 | UNIT PRICE | PRICE | | | | | | |
| 20.11.05 | 26.11.05 | 1.216 | 38.91 | | | | | | | | | | | | | | | | | | | | | | | | | | | | | | | | | | | | | | | | | |
| PACKED ON | SELL BY | WEIGHT | PRICE | | | | | | | | | | | | | | | | | | | | | | | | | | | | | | | | | | | | | | | | | |
| 32.00 | 38.91 | | | | | | | | | | | | | | | | | | | | | | | | | | | | | | | | | | | | | | | | | | | |
| UNIT PRICE | PRICE | | | | | | | | | | | | | | | | | | | | | | | | | | | | | | | | | | | | | | | | | | | |
| 20.11.05 | 26.11.05 | 1.216 | 38.91 | | | | | | | | | | | | | | | | | | | | | | | | | | | | | | | | | | | | | | | | | |
| PACKED ON | SELL BY | WEIGHT | PRICE | | | | | | | | | | | | | | | | | | | | | | | | | | | | | | | | | | | | | | | | | |
| 32.00 | 38.91 | | | | | | | | | | | | | | | | | | | | | | | | | | | | | | | | | | | | | | | | | | | |
| UNIT PRICE | PRICE | | | | | | | | | | | | | | | | | | | | | | | | | | | | | | | | | | | | | | | | | | | |
| 20.11.05 | 26.11.05 | 1.216 | 38.91 | | | | | | | | | | | | | | | | | | | | | | | | | | | | | | | | | | | | | | | | | |
| PACKED ON | SELL BY | WEIGHT | PRICE | | | | | | | | | | | | | | | | | | | | | | | | | | | | | | | | | | | | | | | | | |
| 32.00 | 38.91 | | | | | | | | | | | | | | | | | | | | | | | | | | | | | | | | | | | | | | | | | | | |
| UNIT PRICE | PRICE | | | | | | | | | | | | | | | | | | | | | | | | | | | | | | | | | | | | | | | | | | | |
| 13 | 14 | 15 | | | | | | | | | | | | | | | | | | | | | | | | | | | | | | | | | | | | | | | | | | |
| <p>SWEETENED CONDENSED <VERY SWEET and STICKY></p> <p>PACKED ON</p> <table border="1"> <tr> <td>20.11.05</td> <td>38.91</td> </tr> <tr> <td>PACKED ON</td> <td>PRICE</td> </tr> </table> <p>SELL BY</p> <table border="1"> <tr> <td>26.11.05</td> <td>38.91</td> </tr> <tr> <td>SELL BY</td> <td>PRICE</td> </tr> </table> <p>Tare(kg) : 0.100</p> <table border="1"> <tr> <td>1.216</td> <td>32.00</td> <td>38.91</td> </tr> <tr> <td>NET WT</td> <td>PRICE / kg</td> <td>TOTAL PRICE</td> </tr> </table> <p>CAS CORPORATION +82-31-820-1100 #19 Gangp-ri</p> | 20.11.05 | 38.91 | PACKED ON | PRICE | 26.11.05 | 38.91 | SELL BY | PRICE | 1.216 | 32.00 | 38.91 | NET WT | PRICE / kg | TOTAL PRICE | <p>SWEETENED CONDENSED Whole milk that had 60% of the water removed and sugar added. The amount of sugar added</p> <p>PACKED ON</p> <table border="1"> <tr> <td>20.11.05</td> <td>38.91</td> </tr> <tr> <td>PACKED ON</td> <td>PRICE</td> </tr> </table> <p>SELL BY</p> <table border="1"> <tr> <td>26.11.05</td> <td>38.91</td> </tr> <tr> <td>SELL BY</td> <td>PRICE</td> </tr> </table> <p>Tare(kg) : 0.100</p> <table border="1"> <tr> <td>1.216</td> <td>32.00</td> <td>38.91</td> </tr> <tr> <td>NET WT</td> <td>PRICE / kg</td> <td>TOTAL PRICE</td> </tr> </table> <p>CAS CORPORATION +82-31-820-1100 #19 Gangp-ri</p> | 20.11.05 | 38.91 | PACKED ON | PRICE | 26.11.05 | 38.91 | SELL BY | PRICE | 1.216 | 32.00 | 38.91 | NET WT | PRICE / kg | TOTAL PRICE | <p>SWEETENED CONDENSED</p> <p>PACKED ON</p> <table border="1"> <tr> <td>20.11.05</td> <td>38.91</td> </tr> <tr> <td>PACKED ON</td> <td>PRICE</td> </tr> </table> <p>SELL BY</p> <table border="1"> <tr> <td>26.11.05</td> <td>38.91</td> </tr> <tr> <td>SELL BY</td> <td>PRICE</td> </tr> </table> <p>Tare(kg) : 0.100</p> <table border="1"> <tr> <td>1.216</td> <td>32.00</td> <td>38.91</td> </tr> <tr> <td>NET WT</td> <td>PRICE / kg</td> <td>TOTAL PRICE</td> </tr> </table> <p>CAS CORPORATION +82-31-820-1100 #19 Gangp-ri</p> | 20.11.05 | 38.91 | PACKED ON | PRICE | 26.11.05 | 38.91 | SELL BY | PRICE | 1.216 | 32.00 | 38.91 | NET WT | PRICE / kg | TOTAL PRICE |
| 20.11.05 | 38.91 | | | | | | | | | | | | | | | | | | | | | | | | | | | | | | | | | | | | | | | | | | | |
| PACKED ON | PRICE | | | | | | | | | | | | | | | | | | | | | | | | | | | | | | | | | | | | | | | | | | | |
| 26.11.05 | 38.91 | | | | | | | | | | | | | | | | | | | | | | | | | | | | | | | | | | | | | | | | | | | |
| SELL BY | PRICE | | | | | | | | | | | | | | | | | | | | | | | | | | | | | | | | | | | | | | | | | | | |
| 1.216 | 32.00 | 38.91 | | | | | | | | | | | | | | | | | | | | | | | | | | | | | | | | | | | | | | | | | | |
| NET WT | PRICE / kg | TOTAL PRICE | | | | | | | | | | | | | | | | | | | | | | | | | | | | | | | | | | | | | | | | | | |
| 20.11.05 | 38.91 | | | | | | | | | | | | | | | | | | | | | | | | | | | | | | | | | | | | | | | | | | | |
| PACKED ON | PRICE | | | | | | | | | | | | | | | | | | | | | | | | | | | | | | | | | | | | | | | | | | | |
| 26.11.05 | 38.91 | | | | | | | | | | | | | | | | | | | | | | | | | | | | | | | | | | | | | | | | | | | |
| SELL BY | PRICE | | | | | | | | | | | | | | | | | | | | | | | | | | | | | | | | | | | | | | | | | | | |
| 1.216 | 32.00 | 38.91 | | | | | | | | | | | | | | | | | | | | | | | | | | | | | | | | | | | | | | | | | | |
| NET WT | PRICE / kg | TOTAL PRICE | | | | | | | | | | | | | | | | | | | | | | | | | | | | | | | | | | | | | | | | | | |
| 20.11.05 | 38.91 | | | | | | | | | | | | | | | | | | | | | | | | | | | | | | | | | | | | | | | | | | | |
| PACKED ON | PRICE | | | | | | | | | | | | | | | | | | | | | | | | | | | | | | | | | | | | | | | | | | | |
| 26.11.05 | 38.91 | | | | | | | | | | | | | | | | | | | | | | | | | | | | | | | | | | | | | | | | | | | |
| SELL BY | PRICE | | | | | | | | | | | | | | | | | | | | | | | | | | | | | | | | | | | | | | | | | | | |
| 1.216 | 32.00 | 38.91 | | | | | | | | | | | | | | | | | | | | | | | | | | | | | | | | | | | | | | | | | | |
| NET WT | PRICE / kg | TOTAL PRICE | | | | | | | | | | | | | | | | | | | | | | | | | | | | | | | | | | | | | | | | | | |

| 16 | 17 | 18 | | | | | | | | | | | | | | | | | | | | | | | | | | | | | | | | | | | | | | | | | | | | | | | | |
|--|-----------|-----------|--------------------|--------------|----------|----------|----------|-------|-------|-------|--|--------------------|--|--------------------|--------------|---|---|-----------|-----------|------------|-----------|----------|----------|-------|-------|-------|--|--|--------------------|--------------------|--------------|---|--------------|--|-----------|-----------|----------|-----------|----------|----------|-------|-------|--|--------------------|--|--------------------|--|--------------|--|--------------|
| <p>SWEETENED CONDENSED MILK <VERY SWEET and STICKY></p> <p>Whole milk that had 60% of the water remove and sugar added. The amount of sugar added makes up 40% of the sweetened condensed milk volume. It is very sweet and sticky and adds a richness to the foods it is added to. It is used to make candies, bars, pies, and puddings. Sweetened condensed milk turns a</p> <table border="1"> <tr> <td>SELL BY</td> <td>PACKED ON</td> <td>kg</td> <td>NET WT/kg</td> </tr> <tr> <td>26.11.05</td> <td>26.11.05</td> <td>1.216</td> <td>32.00</td> </tr> <tr> <td colspan="3"></td> <td>TOTAL PRICE</td> </tr> <tr> <td colspan="3"></td> <td>38.91</td> </tr> </table> <p>TRINK YOU CAS CORPORATION +82-31-820-1100 #19 Gannap-11 Gwangju-Myun</p> | SELL BY | PACKED ON | kg | NET WT/kg | 26.11.05 | 26.11.05 | 1.216 | 32.00 | | | | TOTAL PRICE | | | | 38.91 | <p>SWEETENED CONDENSED MILK</p> <p>Whole milk that had 60% of the water remove and sugar added. The amount of sugar added makes up 40% of the sweetened condensed milk volume. It is very sweet and sticky and adds a richness to the foods it is added to. It is used to make candies, bars, pies, and puddings. Sweetened condensed milk turns a</p> <table border="1"> <tr> <td>SELL BY</td> <td>PACKED ON</td> <td>kg</td> <td>NET WT/kg</td> </tr> <tr> <td>26.11.05</td> <td>26.11.05</td> <td>1.216</td> <td>32.00</td> </tr> <tr> <td colspan="3"></td> <td>TOTAL PRICE</td> </tr> <tr> <td colspan="3"></td> <td>38.91</td> </tr> </table> <p>TRINK YOU CAS CORPORATION +82-31-820-1100 #19 Gannap-11 Gwangju-Myun</p> | SELL BY | PACKED ON | kg | NET WT/kg | 26.11.05 | 26.11.05 | 1.216 | 32.00 | | | | TOTAL PRICE | | | | 38.91 | <p>SWEETENED CONDENSED <VERY SWEET and STICKY></p> <p>Whole milk that had 60% of the water remove and sugar added. The amount of sugar added makes up 40% of the sweetened condensed milk volume. It is very sweet and sticky and adds a richness to the foods it is added to. It is used to make candies, bars, pies, and puddings. Sweetened condensed milk turns a</p> <table border="1"> <tr> <td>PACKED ON</td> <td>SELL BY</td> <td>kg</td> <td>NET WT/kg</td> </tr> <tr> <td>26.11.05</td> <td>26.11.05</td> <td>1.216</td> <td>32.00</td> </tr> <tr> <td colspan="3"></td> <td>TOTAL PRICE</td> </tr> <tr> <td colspan="3"></td> <td>38.91</td> </tr> </table> <p>CAS CORPORATION +82-31-820-1100 #19 Gannap-11</p> | PACKED ON | SELL BY | kg | NET WT/kg | 26.11.05 | 26.11.05 | 1.216 | 32.00 | | | | TOTAL PRICE | | | | 38.91 |
| SELL BY | PACKED ON | kg | NET WT/kg | | | | | | | | | | | | | | | | | | | | | | | | | | | | | | | | | | | | | | | | | | | | | | | |
| 26.11.05 | 26.11.05 | 1.216 | 32.00 | | | | | | | | | | | | | | | | | | | | | | | | | | | | | | | | | | | | | | | | | | | | | | | |
| | | | TOTAL PRICE | | | | | | | | | | | | | | | | | | | | | | | | | | | | | | | | | | | | | | | | | | | | | | | |
| | | | 38.91 | | | | | | | | | | | | | | | | | | | | | | | | | | | | | | | | | | | | | | | | | | | | | | | |
| SELL BY | PACKED ON | kg | NET WT/kg | | | | | | | | | | | | | | | | | | | | | | | | | | | | | | | | | | | | | | | | | | | | | | | |
| 26.11.05 | 26.11.05 | 1.216 | 32.00 | | | | | | | | | | | | | | | | | | | | | | | | | | | | | | | | | | | | | | | | | | | | | | | |
| | | | TOTAL PRICE | | | | | | | | | | | | | | | | | | | | | | | | | | | | | | | | | | | | | | | | | | | | | | | |
| | | | 38.91 | | | | | | | | | | | | | | | | | | | | | | | | | | | | | | | | | | | | | | | | | | | | | | | |
| PACKED ON | SELL BY | kg | NET WT/kg | | | | | | | | | | | | | | | | | | | | | | | | | | | | | | | | | | | | | | | | | | | | | | | |
| 26.11.05 | 26.11.05 | 1.216 | 32.00 | | | | | | | | | | | | | | | | | | | | | | | | | | | | | | | | | | | | | | | | | | | | | | | |
| | | | TOTAL PRICE | | | | | | | | | | | | | | | | | | | | | | | | | | | | | | | | | | | | | | | | | | | | | | | |
| | | | 38.91 | | | | | | | | | | | | | | | | | | | | | | | | | | | | | | | | | | | | | | | | | | | | | | | |
| <p>SWEETENED CONDENSED</p> <p>Whole milk that had 60% of the water remove and sugar added. The amount of sugar added makes up 40% of the sweetened condensed milk volume. It is very sweet and sticky and adds a richness to the foods it is added to. It is used to make candies, bars, pies, and puddings. Sweetened condensed milk turns a</p> <table border="1"> <tr> <td>PACKED ON</td> <td>SELL BY</td> <td>kg</td> <td>NET WT/kg</td> </tr> <tr> <td>26.11.05</td> <td>26.11.05</td> <td>1.216</td> <td>32.00</td> </tr> <tr> <td colspan="3"></td> <td>TOTAL PRICE</td> </tr> <tr> <td colspan="3"></td> <td>38.91</td> </tr> </table> <p>CAS CORPORATION +82-31-820-1100 #19 Gannap-11</p> | PACKED ON | SELL BY | kg | NET WT/kg | 26.11.05 | 26.11.05 | 1.216 | 32.00 | | | | TOTAL PRICE | | | | 38.91 | <p>SWEETENED CONDENSED MILK <VERY SWEET and STICKY></p> <p>Whole milk that had 60% of the water remove and sugar added. The amount of sugar added makes up 40% of the sweetened condensed milk volume. It is very sweet and sticky and adds a richness to the foods it is added to.</p> <table border="1"> <tr> <td>PACKED ON</td> <td>SELL BY</td> <td>kg</td> <td>NET WT/kg</td> </tr> <tr> <td>26.11.05</td> <td>26.11.05</td> <td>1.216</td> <td>32.00</td> </tr> <tr> <td colspan="3"></td> <td>TOTAL PRICE</td> </tr> <tr> <td colspan="3"></td> <td>38.91</td> </tr> </table> <p>CAS CORPORATION +82-31-820-1100 #19 Gannap-11 Gwangju-Myun</p> | PACKED ON | SELL BY | kg | NET WT/kg | 26.11.05 | 26.11.05 | 1.216 | 32.00 | | | | TOTAL PRICE | | | | 38.91 | <p>SWEETENED CONDENSED MILK</p> <p>Whole milk that had 60% of the water remove and sugar added. The amount of sugar added makes up 40% of the sweetened condensed milk volume. It is very sweet and sticky and adds a richness to the foods it is added to.</p> <table border="1"> <tr> <td>PACKED ON</td> <td>SELL BY</td> <td>kg</td> <td>NET WT/kg</td> </tr> <tr> <td>26.11.05</td> <td>26.11.05</td> <td>1.216</td> <td>32.00</td> </tr> <tr> <td colspan="3"></td> <td>TOTAL PRICE</td> </tr> <tr> <td colspan="3"></td> <td>38.91</td> </tr> </table> <p>CAS CORPORATION +82-31-820-1100 #19 Gannap-11 Gwangju-Myun</p> | PACKED ON | SELL BY | kg | NET WT/kg | 26.11.05 | 26.11.05 | 1.216 | 32.00 | | | | TOTAL PRICE | | | | 38.91 |
| PACKED ON | SELL BY | kg | NET WT/kg | | | | | | | | | | | | | | | | | | | | | | | | | | | | | | | | | | | | | | | | | | | | | | | |
| 26.11.05 | 26.11.05 | 1.216 | 32.00 | | | | | | | | | | | | | | | | | | | | | | | | | | | | | | | | | | | | | | | | | | | | | | | |
| | | | TOTAL PRICE | | | | | | | | | | | | | | | | | | | | | | | | | | | | | | | | | | | | | | | | | | | | | | | |
| | | | 38.91 | | | | | | | | | | | | | | | | | | | | | | | | | | | | | | | | | | | | | | | | | | | | | | | |
| PACKED ON | SELL BY | kg | NET WT/kg | | | | | | | | | | | | | | | | | | | | | | | | | | | | | | | | | | | | | | | | | | | | | | | |
| 26.11.05 | 26.11.05 | 1.216 | 32.00 | | | | | | | | | | | | | | | | | | | | | | | | | | | | | | | | | | | | | | | | | | | | | | | |
| | | | TOTAL PRICE | | | | | | | | | | | | | | | | | | | | | | | | | | | | | | | | | | | | | | | | | | | | | | | |
| | | | 38.91 | | | | | | | | | | | | | | | | | | | | | | | | | | | | | | | | | | | | | | | | | | | | | | | |
| PACKED ON | SELL BY | kg | NET WT/kg | | | | | | | | | | | | | | | | | | | | | | | | | | | | | | | | | | | | | | | | | | | | | | | |
| 26.11.05 | 26.11.05 | 1.216 | 32.00 | | | | | | | | | | | | | | | | | | | | | | | | | | | | | | | | | | | | | | | | | | | | | | | |
| | | | TOTAL PRICE | | | | | | | | | | | | | | | | | | | | | | | | | | | | | | | | | | | | | | | | | | | | | | | |
| | | | 38.91 | | | | | | | | | | | | | | | | | | | | | | | | | | | | | | | | | | | | | | | | | | | | | | | |
| <p>SWEETENED CONDENSED MILK <VERY SWEET and STICKY></p> <p>Whole milk that had 60% of the water remove and sugar added. The amount of sugar added makes up 40% of the sweetened condensed milk volume. It is very sweet and sticky and adds a richness to the foods it is added to. It is used to make candies, bars, pies, and puddings. Sweetened condensed milk turns a golden color and takes on a caramel like flavor when heated. It is also thicken as it is heated.</p> <table border="1"> <tr> <td>PACKED ON</td> <td>SELL BY</td> <td>WEIGHT</td> <td>UNIT PRICE</td> <td>PRICE</td> </tr> <tr> <td>26.11.05</td> <td>26.11.05</td> <td>22</td> <td>32.00</td> <td>1.216</td> </tr> <tr> <td colspan="3"></td> <td>TOTAL PRICE</td> <td>38.91</td> </tr> </table> <p>CAS CORPORATION +82-31-820-1100 #19 Gannap-11 Gwangju-Myun</p> | PACKED ON | SELL BY | WEIGHT | UNIT PRICE | PRICE | 26.11.05 | 26.11.05 | 22 | 32.00 | 1.216 | | | | TOTAL PRICE | 38.91 | <p>SWEETENED CONDENSED MILK</p> <p>Whole milk that had 60% of the water remove and sugar added. The amount of sugar added makes up 40% of the sweetened condensed milk volume. It is very sweet and sticky and adds a richness to the foods it is added to. It is used to make candies, bars, pies, and puddings. Sweetened condensed milk turns a golden color and takes on a caramel like flavor when heated. It is also thicken as it is heated.</p> <table border="1"> <tr> <td>PACKED ON</td> <td>SELL BY</td> <td>WEIGHT</td> <td>UNIT PRICE</td> <td>PRICE</td> </tr> <tr> <td>26.11.05</td> <td>26.11.05</td> <td>23</td> <td>32.00</td> <td>1.216</td> </tr> <tr> <td colspan="3"></td> <td>TOTAL PRICE</td> <td>38.91</td> </tr> </table> <p>CAS CORPORATION +82-31-820-1100 #19 Gannap-11 Gwangju-Myun</p> | PACKED ON | SELL BY | WEIGHT | UNIT PRICE | PRICE | 26.11.05 | 26.11.05 | 23 | 32.00 | 1.216 | | | | TOTAL PRICE | 38.91 | <p>SWEETENED CONDENSED <VERY SWEET and STICKY></p> <p>Whole milk that had 60% of the water remove and sugar added. The amount of sugar added makes up 40% of the sweetened condensed milk volume. It is very sweet and sticky and adds a richness to the foods it is added to. It is used to make candies, bars, pies, and puddings. Sweetened condensed milk turns a golden color and takes on a caramel like flavor when heated. It is also thicken as it is heated.</p> <table border="1"> <tr> <td>PACKED ON</td> <td>SELL BY</td> <td>kg</td> <td>NET WT/kg</td> </tr> <tr> <td>26.11.05</td> <td>26.11.05</td> <td>1.216</td> <td>32.00</td> </tr> <tr> <td colspan="3"></td> <td>TOTAL PRICE</td> </tr> <tr> <td colspan="3"></td> <td>38.91</td> </tr> </table> <p>CAS CORPORATION +82-31-820-1100 #19 Gannap-11</p> | PACKED ON | SELL BY | kg | NET WT/kg | 26.11.05 | 26.11.05 | 1.216 | 32.00 | | | | TOTAL PRICE | | | | 38.91 | | |
| PACKED ON | SELL BY | WEIGHT | UNIT PRICE | PRICE | | | | | | | | | | | | | | | | | | | | | | | | | | | | | | | | | | | | | | | | | | | | | | |
| 26.11.05 | 26.11.05 | 22 | 32.00 | 1.216 | | | | | | | | | | | | | | | | | | | | | | | | | | | | | | | | | | | | | | | | | | | | | | |
| | | | TOTAL PRICE | 38.91 | | | | | | | | | | | | | | | | | | | | | | | | | | | | | | | | | | | | | | | | | | | | | | |
| PACKED ON | SELL BY | WEIGHT | UNIT PRICE | PRICE | | | | | | | | | | | | | | | | | | | | | | | | | | | | | | | | | | | | | | | | | | | | | | |
| 26.11.05 | 26.11.05 | 23 | 32.00 | 1.216 | | | | | | | | | | | | | | | | | | | | | | | | | | | | | | | | | | | | | | | | | | | | | | |
| | | | TOTAL PRICE | 38.91 | | | | | | | | | | | | | | | | | | | | | | | | | | | | | | | | | | | | | | | | | | | | | | |
| PACKED ON | SELL BY | kg | NET WT/kg | | | | | | | | | | | | | | | | | | | | | | | | | | | | | | | | | | | | | | | | | | | | | | | |
| 26.11.05 | 26.11.05 | 1.216 | 32.00 | | | | | | | | | | | | | | | | | | | | | | | | | | | | | | | | | | | | | | | | | | | | | | | |
| | | | TOTAL PRICE | | | | | | | | | | | | | | | | | | | | | | | | | | | | | | | | | | | | | | | | | | | | | | | |
| | | | 38.91 | | | | | | | | | | | | | | | | | | | | | | | | | | | | | | | | | | | | | | | | | | | | | | | |

| 37 | 38 | 39 |
|--|--|--|
| <p>SWEETENED CONDENSED MILK <VERY SWEET and STICKY></p> <p>UNIT PRICE 32.00 WEIGHT 1.216 38.91</p> <p>0 10204 0569 10 37 20.11.05 16:32 26.11.05 16:32 PACKED ON SELL BY TOTAL PRICE</p> <p>CMS CORPORATION +82-31-820-1100 #19 Ganso-ri Gwangjuk-myun</p> | <p>SWEETENED CONDENSED MILK <VERY SWEET and STICKY></p> <p>UNIT PRICE 32.00 WEIGHT 1.216 38.91</p> <p>0 10204 0569 10 38 20.11.05 16:32 26.11.05 16:32 PACKED ON SELL BY TOTAL PRICE</p> <p>CMS CORPORATION +82-31-820-1100 #19 Ganso-ri Gwangjuk-myun</p> | <p>SWEETENED CONDENSED MILK <VERY SWEET and STICKY></p> <p>UNIT PRICE 32.00 WEIGHT 1.216 38.91</p> <p>0 10204 0569 10 39 20.11.05 16:32 26.11.05 16:32 PACKED ON SELL BY TOTAL PRICE</p> <p>CMS CORPORATION +82-31-820-1100 #19 Ganso-ri Gwangjuk-myun</p> |
| 40 | 41 | 42 |
| <p>SWEETENED CONDENSED MILK Whole milk that had 60% of the water remove and sugar added. The amount of sugar added makes up 40% of the sweetened condensed milk volume. It is very sweet and sticky.</p> <p>UNIT PRICE 32.00 WEIGHT 1.216 38.91</p> <p>0 10204 0569 10 40 20.11.05 16:32 26.11.05 16:32 PACKED ON SELL BY TOTAL PRICE</p> <p>CMS CORPORATION +82-31-820-1100 #19 Ganso-ri Gwangjuk-myun</p> | <p>SWEETENED CONDENSED MILK Whole milk that had 60% of the water remove and sugar added. The amount of sugar added makes up 40% of the sweetened condensed milk volume. It is very sweet and sticky.</p> <p>UNIT PRICE 32.00 WEIGHT 1.216 38.91</p> <p>0 10204 0569 10 41 20.11.05 16:32 26.11.05 16:32 PACKED ON SELL BY TOTAL PRICE</p> <p>CMS CORPORATION +82-31-820-1100 #19 Ganso-ri Gwangjuk-myun</p> | <p>SWEETENED CONDENSED MILK <VERY SWEET and STICKY></p> <p>Whole milk that had 60% of the water remove and sugar added. The amount of sugar added makes up 40% of the sweetened condensed milk volume. It is very sweet and sticky.</p> <p>UNIT PRICE 32.00 WEIGHT 1.216 38.91</p> <p>0 10204 0569 10 42 20.11.05 16:32 26.11.05 16:32 PACKED ON SELL BY TOTAL PRICE</p> <p>CMS CORPORATION +82-31-820-1100 #19 Ganso-ri Gwangjuk-myun</p> |
| 43 | 44 | 45 |
| <p>SWEETENED CONDENSED MILK <VERY SWEET and STICKY></p> <p>Whole milk that had 60% of the water remove and sugar added. The amount of sugar added makes up 40% of the sweetened condensed milk volume. It is very sweet and sticky.</p> <p>UNIT PRICE 32.00 WEIGHT 1.216 38.91</p> <p>0 10204 0569 10 43 20.11.05 16:32 26.11.05 16:32 PACKED ON SELL BY TOTAL PRICE</p> <p>CMS CORPORATION +82-31-820-1100 #19 Ganso-ri Gwangjuk-myun</p> | <p>SWEETENED CONDENSED MILK Whole milk that had 60% of the water remove and sugar added. The amount of sugar added makes up 40% of the sweetened condensed milk volume. It is very sweet and sticky.</p> <p>UNIT PRICE 32.00 WEIGHT 1.216 38.91</p> <p>0 10204 0569 10 44 20.11.05 16:32 26.11.05 16:32 PACKED ON SELL BY TOTAL PRICE</p> <p>CMS CORPORATION +82-31-820-1100 #19 Ganso-ri Gwangjuk-myun</p> | <p>SWEETENED CONDENSED MILK Whole milk that had 60% of the water remove and sugar added. The amount of sugar added makes up 40% of the sweetened condensed milk volume. It is very sweet and sticky.</p> <p>UNIT PRICE 32.00 WEIGHT 1.216 38.91</p> <p>0 10204 0569 10 45 20.11.05 16:32 26.11.05 16:32 PACKED ON SELL BY TOTAL PRICE</p> <p>CMS CORPORATION +82-31-820-1100 #19 Ganso-ri Gwangjuk-myun</p> |

4.2 Fixed Label Format Sample

► (1) Label sample 1

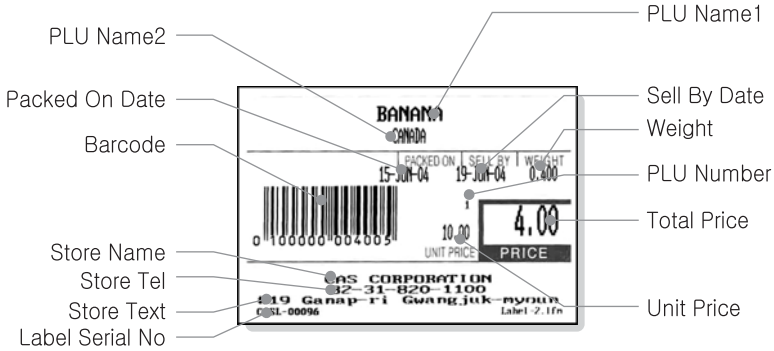

► (2) Label sample 2

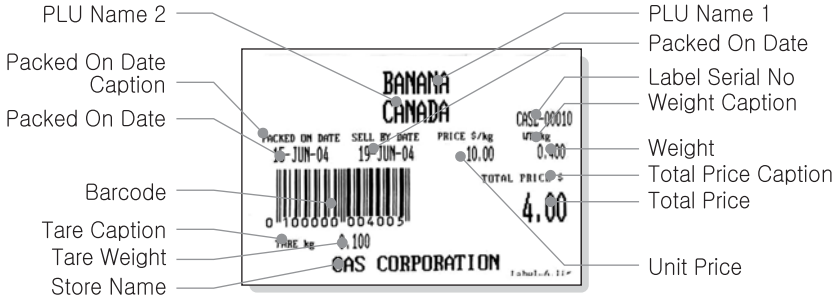

4.3 Fixed Label Format Sample

Label Format has several fields and each field has own ID. Item label print the information of each PLU sale and Total label print the information of grand total of PLUs. Item Label field is separate from Total Label field. But the information of store and clerk is common item.

4.3.1 Item Label Field

► (1) Item Field

| No | Item | Field ID | Description |
|----|-----------------|----------|--|
| 1 | Department Name | 1 | Print department name. |
| 2 | Department No | 115 | Print department number. |
| 3 | Group No | 9 | Print group number |
| 4 | PLU No | 2 | Print PLU number |
| 5 | PLU Name | 10 | Print PLU name1,2 and 3 in one field |
| 6 | PLU Name1 | 29 | Print PLU name1,2 and 3. Depending on the setting of MENU 1862 "Print origin for comm. line", Origin can be printed. |
| 7 | PLU Name2 | 30 | |
| 8 | PLU Name3 | 31 | |
| 9 | Item Code | 11 | Print item code |
| 10 | Prefix | 3 | Print prefix |
| 11 | Unit Weight | 5 | Print unit weight |
| 12 | Tax Rate | 8 | Print tax rate. It is printed with %. |
| 13 | Tax Price | 111 | Print tax price. |
| 14 | Tare Weight | 13 | Print tare weight. |
| 15 | Pieces | 14 | Print Piece for By-Pcs PLU |
| 16 | Qty Symbol | 15 | Print symbol of Quantity. |
| 17 | Sell By Date | 16 | Print sell by date. |
| 18 | Sell By Time | 17 | Print sell by time. If sell by time is 0, it is not printed |
| 19 | Packed On Date | 18 | Print packed on date. |
| 20 | Packed On Time | 19 | Print packed on time |
| 21 | Produced Date | 20 | Print produced date. If produced date is 0, it is not printed |
| 22 | Cook By Date | 22 | Print cook by date. If cook by date is 0, it is not printed |
| 23 | Bonus Point | 50 | Print bonus point. |
| 24 | Origin | 55 | Print origin |
| 25 | Ingredient | 25 | Print ingredient |
| 26 | Sales Message | 90 | Print sales message |

| | | | |
|----|----------------------------------|-----|---|
| 27 | Reference Net Weight | 100 | Print net weight. In case of By-Count/By-Pcs PLU, net weight is printed when you print weight. In case of By-Weight PLU, net weight is printed when you use percent tare. |
| 28 | Reference Gross Weight | 116 | Print gross weight. In case of By-Weight PLU, gross weight is printed when you use percent tare. |
| 29 | Percent Tare | 24 | Print percent tare. It is printed with %. |
| 30 | Percent Tare Limit | 23 | Print percent tare limit. It is printed with %. |
| 31 | Weight | 101 | Print weight when it is not applied Markdown (By-Weight PLU) |
| 32 | Discount Weight | 132 | Print new weight when it is applied Markdown (By-Weight PLU) |
| 33 | Discount Weight (Mark Down) | 108 | Print previous weight when it is applied Markdown (By-Weight PLU) |
| 34 | Quantity | 112 | Print quantity when it is not applied Markdown (By-Count/By-Pcs PLU) |
| 35 | Discount Quantity | 133 | Print new quantity when it is applied Markdown (By-Count/By-Pcs PLU) |
| 36 | Discount Quantity (Mark Down) | 134 | Print previous quantity when it is applied Markdown (By-Count/By-Pcs PLU) |
| 37 | Unit Price | 6 | Print unit price when it is not applied Markdown |
| 38 | Discount Unit Price | 113 | Print new unit price when it is applied Markdown |
| 39 | Discount Unit Price (Mark Down) | 118 | Print previous unit price when it is applied Markdown. |
| 40 | Total Price | 102 | Print total price when it is not applied Markdown |
| 41 | Discount Total Price | 114 | Print new total price when it is applied Markdown |
| 42 | Discount Total Price (Mark Down) | 110 | Print previous total price when it is applied Markdown |
| 43 | Saved Price | 131 | Print saved price when it is discounted. |
| 44 | Label Serial | 135 | Print label serial number |
| 45 | Store Name | 105 | Print store name |
| 46 | Store Tel | 138 | Print Telephone numer of store |
| 47 | Store Text | 139 | Print information of store. |
| 48 | Clerk Number | 128 | Print clerk number |
| 49 | Clerk Name | 106 | Print clerk name |
| 50 | Customer Name | 107 | Print customer name |
| 51 | Customer Number | 130 | Print customer number |
| 52 | Scale Number | 137 | Print scale number |
| 53 | Day Of Week(Packed On) | 117 | Print Day Of Week(Packed On Date) |
| 54 | Currency Rate | 119 | Print Currency Rate |
| 55 | Second Currency Total Price | 118 | Print Second Currency Total Price |
| 56 | Second Currency Unit Price | 120 | Print Second Currency Unit Price |

► (2) Caption Field

| No | Item | Field ID | Description |
|----|--------------------------------|----------|---|
| 1 | (C)Total Price | 170 | Print the caption of total price |
| 2 | (C)Unit Price | 171 | Print the caption of unit price |
| 3 | (C)Weight | 172 | Print the caption of weight (Only By-Weight PLU) |
| 4 | (C)Tare | 173 | Print the caption of tare weight |
| 5 | (C)Saved Price | 174 | Print the caption of saved price |
| 6 | (C)Regular Price | 175 | Print the caption of regular price |
| 7 | (C)Tax Price | 176 | Print the caption of tax price |
| 8 | (C)Packed On Date | 177 | Print the caption of packed on date |
| 9 | (C)Sell By Date | 178 | Print the caption of Sell By Date/Time if it is existed. |
| 10 | (C)Cook By Date | 179 | Print the caption of Cook By Date. If the value is 0, it is not printed. |
| 11 | (C)Produced Date | 180 | Print the caption of Produced Date. If the value is 0, it is not printed. |
| 12 | (C)Packed On Time | 181 | Print the caption of Packed On Time |
| 13 | (C)Sell By Time | 182 | Print the caption of Sell By Time. If the value is 0, it is not printed. |
| 14 | (C)Quantity | 183 | Print the caption of quantity. (By-Count/By-Pcs PLU) |
| 15 | (C)Reference | 184 | Print the caption of Traceability Reference |
| 16 | (C)Born In | 185 | Print the caption of Born In Country |
| 17 | (C)Bred In | 186 | Print the caption of Bred In Country |
| 18 | (C)Slaughtered In | 187 | Print the caption of Slaughter House |
| 19 | (C)Cut In | 188 | Print the caption of Cutting Hall. |
| 20 | (C)Net Weight | 189 | Print the caption of Net Weight |
| 21 | (C)Gross Weight | 193 | Print the caption of Gross Weight |
| 22 | (C)Percent Tare | 194 | Print the caption of Percent Tare |
| 23 | (C)Percent Tare Limit | 195 | Print the caption of Percent Tare Limit |
| 24 | (C)Second Currency Total Price | 198 | Print the caption of second currency total price |
| 25 | (C)Second Currency Unit Price | 199 | Print the caption of second currency unit price |

► (3) Traceability Field

| No | Item | Field ID | Description |
|----|-----------------------|----------|------------------------------------|
| 1 | (T)Traceability No | 35 | Print Traceability Number |
| 2 | (T)Born in Country | 36 | Print Born In Country Name |
| 3 | (T)Bred in Country | 37 | Print Bred In Country Name |
| 4 | (T)Slaughter House | 38 | Print Slaughter House Name |
| 5 | (T)Slaughter Country | 39 | Print Slaughter House Country Name |
| 6 | (T)Cutting Hall | 40 | Print Cutting Hall Name |
| 7 | (T)Cutting Country | 41 | Print Cutting Hall Country Name |
| 8 | (T)Reference | 42 | Print Reference |
| 9 | (T)Born in Country No | 43 | Print Born In Country Number |
| 10 | (T)Bred in Country No | 44 | Print Bred In Country Number |
| 11 | (T)Slaughter House No | 45 | Slaughter House Number |
| 12 | (T)Cutting Hall No | 46 | Print Cutting Hall Number |

► (4) Nutrition Facts Field

| No | Item | Field ID | Description |
|----|---------------------------|----------|--|
| 1 | (N)Serving Size | 140 | Print Serving Size |
| 2 | (N)Servings Per | 141 | Print Servings Per Container |
| 3 | (N)Calories | 142 | Print Calories |
| 4 | (N)Calories From Fat | 143 | Print Calories From Fat |
| 5 | (N)Total Fat | 144 | Print Total Fat |
| 6 | (N)Saturated Fat | 145 | Print Saturated Fat |
| 7 | (N)Cholesterol | 146 | Print Cholesterol |
| 8 | (N)Sodium | 147 | Print Sodium |
| 9 | (N)Total Carbohydrates | 148 | Print Total Carbohydrates |
| 10 | (N)Dietary Fibers | 149 | Print Dietary Fibers |
| 11 | (N)Sugars | 150 | Print Sugars |
| 12 | (N)Protein | 151 | Print Protein |
| 13 | (N)Vitamin A | 152 | Print Vitamin A |
| 14 | (N)Calcium | 153 | Print Calcium |
| 15 | (N)Vitamin C | 154 | Print Vitamin C |
| 16 | (N)Iron | 155 | Print Iron |
| 17 | (N)Total Fat DV | 156 | Print Daily Value of Total Fat |
| 18 | (N)Saturated Fat DV | 157 | Print Daily Value of Saturated Fat |
| 19 | (N)Cholesterol DV | 158 | Print Daily Value of Colesterol. |
| 20 | (N)Sodium DV | 159 | Print Daily Value of Sodium |
| 21 | (N)Total Carbohydrates DV | 160 | Print Daily Value of Total Carbohydrates |
| 22 | (N)Dietary Fibers DV | 161 | Print Daily Value of Dietary Fibers |
| 23 | (N)Protein DV | 162 | Print Daily Value of Protein |

4.3.2 Total Label Field

► (1) Total Field

| No | Item | Field ID | Description |
|----|---------------------------------------|----------|-----------------------------------|
| 1 | (TOTAL)Total Price | 201 | Print total price |
| 2 | (TOTAL)Total Count | 202 | Print total number of item |
| 3 | (TOTAL)Void Price | 203 | Print voided price |
| 4 | (TOTAL)Void Count | 204 | Print voided number of |
| 5 | (TOTAL)Internal Tax Amount | 205 | Print internal tax price |
| 6 | (TOTAL)External Tax Amount | 206 | Print external tax price |
| 7 | (TOTAL)Total Price (Exclude Tax) | 207 | Print total price exclude tax |
| 8 | (TOTAL)Total Price (Include Tax) | 211 | Print total price include tax |
| 9 | (TOTAL)Payment Price | 208 | Print payment price |
| 10 | (TOTAL)Change Price | 209 | Print change price |
| 11 | (TOTAL)Current Date | 103 | Print current date |
| 12 | (TOTAL)Current Time | 104 | Print current time |
| 13 | (TOTAL)Total Tax Amount | 210 | Print total tax amount |
| 14 | (TOTAL)Second Currency Total Price | 212 | Print second currency total price |
| 15 | Store Name | 105 | Print store name |
| 16 | Store Tel | 138 | Print telephone number of store |
| 17 | Store Text | 139 | Print information of store |
| 18 | Clerk Number | 128 | Print clerk number |
| 19 | Clerk Name | 106 | Print clerk name |
| 20 | Customer Name | 107 | Print customer name |
| 21 | Customer ID | 130 | Print customer ID |
| 22 | Scale Number | 137 | Print scale number |
| 23 | Currency Rate | 119 | Print currency rate |

► (2) Caption Fieldd

| No | Item | Field ID | Description |
|----|--|----------|--|
| 1 | (C)Total Count for Total Label | 190 | Print the caption of total Item number |
| 2 | (C)Payment Price for Total Label | 191 | Print the caption of payment |
| 3 | (C)Change Price for Total Label | 192 | Print the caption of change price |
| 4 | (C)Total Price for Total Label | 196 | Print the caption of total price |
| 5 | (C)Total Tax for Total Label | 197 | Print the caption of total tax price |
| 6 | (C)Second Currency Total Price for Total Label | 200 | Print the caption of second currency total price |
| 7 | (C)Void Price for Total Label | 169 | Print the cpatoin of void price |

4.4 ASCII Code Table

► Microsoft Window Codepage 1252

| | 00 | 01 | 02 | 03 | 04 | 05 | 06 | 07 | 08 | 09 | 0A | 0B | 0C | 0D | 0E | 0F |
|----|-------------|-------------|-------------|-------------|-------------|-------------|-------------|-------------|-------------|------------|-------------|-------------|------------|------------|------------|-------------|
| 00 | NUL 0000 | STX 0001 | SOT 0002 | ETX 0003 | EOT 0004 | ENQ 0005 | ACK 0006 | BEL 0007 | BS 0008 | HT 0009 | LF 000A | VT 000B | FF 000C | CR 000D | SO 000E | SI 000F |
| 10 | DLE 0010 | DC1 0011 | DC2 0012 | DC3 0013 | DC4 0014 | NAK 0015 | SYN 0016 | ETB 0017 | CAN 0018 | EM 0019 | SUB 001A | ESC 001B | FS 001C | GS 001D | RS 001E | US 001F |
| 20 | SP 0020 | ! | " | # | \$ | % | & | ' | (|) | * | + | , | - | . | / |
| 30 | 0 | 1 | 2 | 3 | 4 | 5 | 6 | 7 | 8 | 9 | : | ; | < | = | > | ? |
| 40 | @ | A | B | C | D | E | F | G | H | I | J | K | L | M | N | O |
| 50 | P | Q | R | S | T | U | V | W | X | Y | Z | [| \ |] | ^ | _ |
| 60 | ` | a | b | c | d | e | f | g | h | i | j | k | l | m | n | o |
| 70 | p | q | r | s | t | u | v | w | x | y | z | { | | } | ~ | DEL 007F |
| 80 | € 20AC | • | ƒ 0192 | “ 201E | … 2026 | † 2020 | ‡ 2021 | ˆ 02C6 | ‰ 2030 | Š 0160 | < 2039 | Œ 0152 | • | Ž 017D | • | • |
| 90 | • | ˆ 2018 | ˜ 2019 | “ 201C | ” 201D | • 2022 | – 2013 | — 2014 | ˘ 02DC | š 2122 | š 0161 | > 203A | œ 0153 | • | ž 017E | ÿ 0178 |
| A0 | NSP 00A0 | ı 00A1 | ı̇ 00A2 | £ 00A3 | ¤ 00A4 | ¥ 00A5 | ı̈ 00A6 | Š 00A7 | © 00A8 | • 00A9 | « 00AA | » 00AB | ¬ 00AC | – 00AD | @ 00AE | — 00AF |
| B0 | ° 00B0 | ± 00B1 | ² 00B2 | ³ 00B3 | ´ 00B4 | µ 00B5 | ¶ 00B6 | · 00B7 | ¸ 00B8 | ¹ 00B9 | º 00BA | » 00BB | ¼ 00BC | ½ 00BD | ¾ 00BE | ¿ 00BF |
| C0 | À 00C0 | Á 00C1 | Â 00C2 | Ã 00C3 | Ä 00C4 | Å 00C5 | Æ 00C6 | Ç 00C7 | È 00C8 | É 00C9 | Ê 00CA | Ë 00CB | Ì 00CC | Í 00CD | Î 00CE | Ï 00CF |
| D0 | Ð 00D0 | Ñ 00D1 | Ò 00D2 | Ó 00D3 | Ô 00D4 | Õ 00D5 | Ö 00D6 | × 00D7 | Ø 00D8 | Ù 00D9 | Ú 00DA | Û 00DB | Ü 00DC | Ý 00DD | Þ 00DE | ß 00DF |
| E0 | à 00E0 | á 00E1 | â 00E2 | ã 00E3 | ä 00E4 | å 00E5 | æ 00E6 | ç 00E7 | è 00E8 | é 00E9 | ê 00EA | ë 00EB | ì 00EC | í 00ED | î 00EE | ï 00EF |
| F0 | ø 00F0 | ñ 00F1 | ò 00F2 | ó 00F3 | ô 00F4 | õ 00F5 | ö 00F6 | ÷ 00F7 | ø 00F8 | ù 00F9 | ú 00FA | û 00FB | ü 00FC | ý 00FD | þ 00FE | ÿ 00FF |

Note: To enter “A”, first you have to read 40 in a row and 01 in a column and type 41.

4.5 Window Character Set Information

| Code | Short Name | Description | Country |
|------|--------------------------|---------------------------|--|
| 1250 | Central Europe | Windows Latin 2 | Albania, Croatia, Czech, Faeroese, Hungarian, Polish, Romanian, Serbian(Latin), Slovak, Slovenian |
| 1251 | Cyrillic | Windows Cyrillic (Slavic) | Byelorussian, Bulgarian, Russian, Ukrainian |
| 1252 | Latin 1 | Windows Latin 1 (ANSI) | Afrikaans, Catalan, Danish, Dutch, English, USA, Canada, New Zealand, Austria, Ireland, South Africa, Finnish, French, Belgium, Switzerland, Luxembourg, German, Austria, Liechtenstein, Italian, Icelandic, Indonesian, Norwegian, Portuguese, Brazil, Spanish, Mexico, Swedish |
| 1253 | Greek | Windows Greek | Greek |
| 1254 | Turkish | Windows Latin 5 (Turkish) | Turkish |
| 1255 | Hebrew | Windows Hebrew | Hebrew |
| 1256 | Arabic | Windows Arabic | Saudi Arabia, Iraq, Egypt, Loby, Algeria, Morocco, Tunisia, Oman, Yemen, Syria, Jordan, Lebanon, Kuwait, United Arab Emirates, Bahrain, Qatar, Farsi |
| 1257 | Baltic | Windows Batic Rim | Estonian, Latvian, Lithuanian |
| 1258 | Vietnam | | Vietnam |
| 874 | Thai | | Thai |
| | | | |
| 932 | Japanese Shift-JIS | | Japan |
| 936 | Simplified Chinese GBK | Simplified Chinese | Chinese, Singapore |
| 949 | Korean | Complete Hangul | Korea |
| 950 | Traditional Chinese BIG5 | Traditional Chinese | Taiwan, HongKong |

MEMO



MEMO

MEMO



MEMO



CL3000 SERIES

Label Printing Scale



CAS BLDG., # 440-1, SUNGNAE-DONG,
GANGDONG-GU, SEOUL, KOREA

TEL_ 82 2 2225 3500

FAX_ 82 2 475 4668

www.globalcas.com